



Simple PWM Boost Converter with I/O Disconnect Solves Malfunctions Caused when $V_{OUT} < V_{IN}$

By Chin Chang, Director of Application Engineering, Power Management
Semtech Corporation

Introduction

Boost power converters have been widely used for Power Factor Correction (PFC) in AC-DC conversions [1] and for power management in battery powered DC-DC conversions [2]. Moving beyond low-power applications, such as cellular phones, smart phones and other portable electronic products, boost converters are being used more and more in medium-power applications. For example, in computing and consumer electronics, boost converter-based LED drivers for notebook displays, LCD TVs and monitors have been developed [3], [4]. In communications and industrial products, simple boost converters are used in satellite dish auxiliary power supplies and peripheral card supplies [5].

A typical pulse-width-modulation (PWM) boost converter along with a simple controller is shown in Figure 1. This diagram illustrates that there is a DC path from input V_{IN} to output V_{OUT} via the inductor L1 and the output rectify diode D1. Such topological properties define the normal operation range of the boost converter at $V_{OUT} \geq V_{IN}$ all the time. In the aforementioned applications, this property is fully utilized to achieve targeted high-efficiency power conversion.

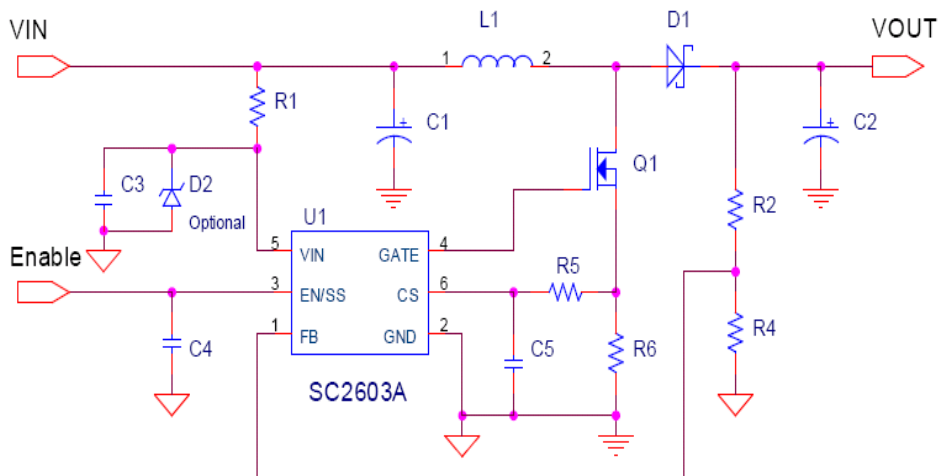

Figure 1: A typical boost converter with a simple controller

However, in practical design and operation of the boost converter, designers can face the challenge of $V_{OUT} < V_{IN}$ under certain conditions and its catastrophic or unwanted consequences. For example,

a) During the boost circuit start up with an uncharged output capacitor C2, huge inrush current results when the V_{IN} charges the output capacitor from 0V to V_{IN} . After this, the output V_{OUT} is boosted to a level greater than or equal to V_{IN} , as normal boost converter start up and operation. One traditional way of limiting the inrush current is to add a current limit resistor in the power path. The issues with this approach are the added power losses during normal operation and the lower circuit efficiency. In some high-power applications, with the expense of added circuitry, the current limit resistor is shortened out after start up.

b) At normal operation, when the circuit output is shortened to ground, there is a direct path to short the input voltage. This could damage the circuit components and cause catastrophic failure of the circuit. In some applications, a fuse (resettable or non-resettable) is added in the power path, even though it is not always accurate.

c) Due to the direct DC path from input to output, once V_{IN} is present, V_{OUT} is moved to V_{IN} level, even though the boost operation is not initiated and the load is not ready.

In some applications, the presence of unwanted V_{OUT} before system start up sequence could cause system latch off or malfunction. To address this issue, a power switch (normally a low-frequency type) needs to be inserted in the input to output path.

Adding an input and output disconnection function in a boost converter easily solves the issues created when $V_{OUT} < V_{IN}$. A simple voltage mode PWM controller with the input disconnect function is shown in Figure 2. It provides a single-chip solution to address the problems that arise when $V_{OUT} < V_{IN}$. The necessary control and protection functions it provides allow high-performance power supply design using a boost converter.

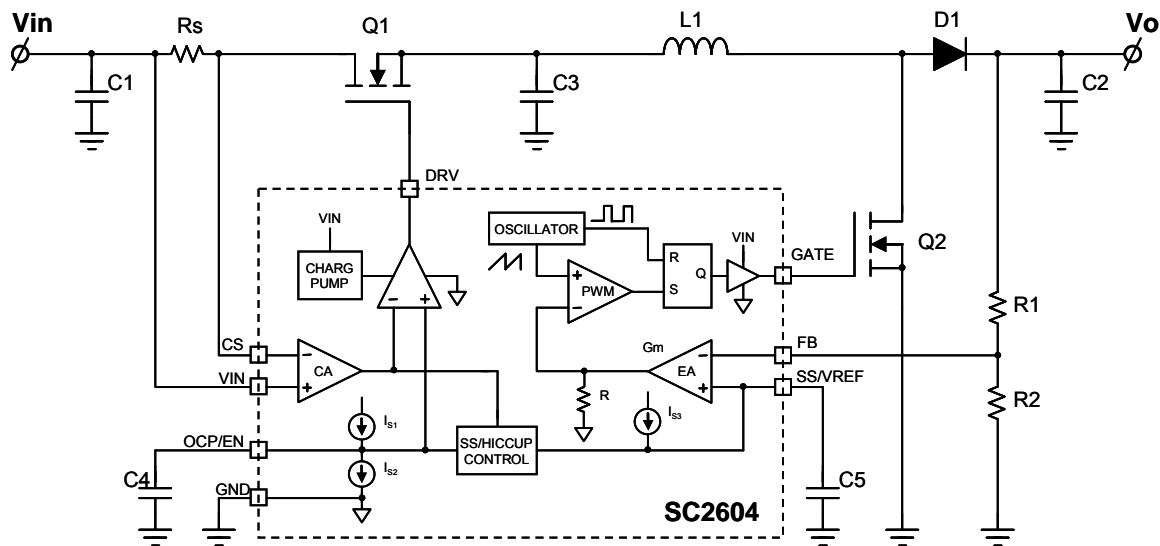

Figure 2: Boost converter with input/output disconnect based on a simple controller

In Figure 2, three new components are added between the input capacitor C1 and the inductor L1 of the traditional boost converter. Q1 is a disconnect switch, normally a low-frequency MOSFET. R_s is a sensing resistor that is used to monitor Q1 (and therefore the input) current. C3 is a small ceramic capacitor, typically 1 μ F, used to help Q1 turn on and prevent a negative voltage spike when Q1 is disconnected hot at heavy current.

This simple IC provides a voltage mode PWM control scheme for the boost converter output regulation. It uses voltage Error Amplifier (EA), oscillator, and PWM comparator blocks. The IC also provides a linear driver for the disconnect switch and includes current amplifier and charge pump blocks. The charge pump generates a floating voltage for Q1 drive, which is referred to the input.

Soft Turn-On to Limit Inrush Current

To limit the start-up inrush current that exists in traditional boost converters, it is suggested to slowly turn on Q1 through linear mode first and then Q2 in switching mode next. The details of the start-up timing are shown in Figure 3.

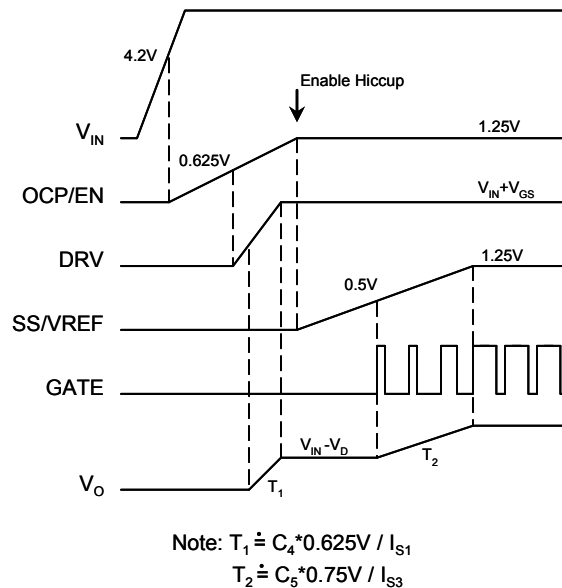

Figure 3: Converter start-up timing diagram

Applying a supply voltage at the V_{IN} pin initiates the IC operation, and the DRV and GATE are held low. When V_{IN} voltage exceeds UVLO (Under Voltage Lockout) threshold (say 4.2V), an internal current source I_{S1} begins to charge the OCP/EN pin capacitor C_4 . The OCP/EN voltage ramps from 0V to over 1.25V while the voltage between 0.625V to 1.25V provides the linear soft-start range for Q1. This is the first part of start up that brings the output from 0V to $(V_{IN}-V_D)$, where V_D is the diode forward drop, with inrush current control. Adjusting the C_4 value can program the converter soft-start time for inrush current control.

When the OCP/EN voltage is over 1.25V, the OCP (Over Current Protection) hiccup is enabled, and the SS/VREF pin is released. At this moment, another internal current source I_{S3} begins to charge the SS/VREF pin capacitor. When the SS/VREF pin voltage reaches 0.5V, the EA output will rise, then the PWM comparator begins to switch as EA output reaches 0.4V. The switching regulator output is slowly ramping up for a soft turn-on. This is the second part of the start-up process that brings the output from $(V_{IN}-V_D)$ to V_{OUT} . The soft-start time can be programmed with a proper capacitor value at SS/VREF pin.

Source-Load Separation During Shutdown

The shutdown of the converter can be achieved by either removing the input supply or pulling the IC control pin low. As the supply voltage at V_{IN} pin falls below UVLO threshold during a normal operation, the DRV pin is pulled low to cut off the supply power of the boost converter, while the OCP/EN pin capacitor is discharged with internal current source I_{S2} . When the OCP/EN pin falls below 1.25V, the SS/VREF pin is forced to ground and the converter output is completely shutdown. Directly pulling the OCP/EN pin below 0.52V by an external circuit can also allow a complete shutdown with source-load separation.

Hiccup Mode Over-Current Protection

A boost converter with hiccup mode over-current protection will allow system auto-retry and ease of trouble shooting. In the circuit of Figure 2, when an increasing load causes a voltage of 72mV (Over Current Threshold setting with Current Sense Resistor) to occur from V_{IN} to CS, a current limit hiccup sequence is started. The sequence starts by pulling DRV low and discharging the OCP/EN pin with a current source I_{S2} . When the OCP/EN pin falls below 1.25V, the SS/VREF pin is forced to ground. This is similar to the UVLO shutdown described in the previous section.

When the voltage on the OCP/EN pin falls to near 0V, the I_{S2} discharge current becomes I_{S1} charging current and the OCP/EN pin starts to charge and DRV is enabled. When the OCP/EN voltage rises from 0.625V to 1.25V, the current in the disconnect switch is allowed to increase from zero up to a maximum value $I_{max} = 72mV/R_s$. If the over-current condition still exists when OCP/EN crosses 1.25V, the hiccup sequence will restart. If there is no over-current as OCP/EN crosses 1.25V, the SS/VREF pin is released to rise and allow a soft-start of the switching boost regulator.

Simple Loop Compensation

A voltage-mode PWM control with a constant gain provides a simple control scheme for boost converters in low-power ($I_o < 2A$) applications. With an all-ceramic design and operating at DCM (Discontinuous Conduction Mode), the small signal characteristic of the converter is a first-order single-pole system. It can be easily compensated without introducing extra poles or zeroes.

As boost converters run to CCM (Continuous Conduction Mode), a complex pole pair and a Right-Half-Plane (RHP) zero will present in the dynamic characteristic. However, the loop compensation can still be simple, if the output capacitor ESR is high enough to null the phase lag from the dominant poles, and the RHP zero is pushed to somewhere way above the crossover frequency. In many medium power ($I_o \sim 2A-5A$) applications, all of these conditions could be met by using aluminum electrolytic output capacitors and properly selecting L1 and C2 values.

A Design Example and Experiment Results

Figure 4 is a typical design for a 12V input and 24V/2A output application operating in CCM.

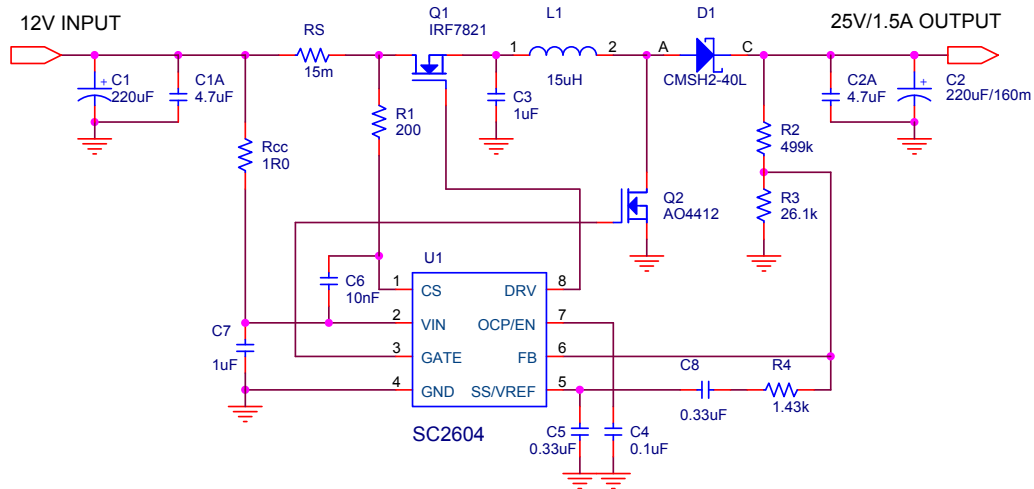

Figure 4: A 12V to 24V/2A, 400kHz boost converter

The branches of (Rcc, C7) and (R1, C6) are noise reduction filters for supply voltage at V_{IN} pin and current sense at CS pin. The system RHP zero is located at 42kHz, but the dominant pole and ESR zero are located at 1.4kHz and 4.5kHz, respectively. The loop crossover is designed at 10kHz, which can be slightly adjusted by the values of (R4, C8). The (R4, C8) branch is equivalent to be connected in parallel with the bottom resistor of the divider, R3.

Figure 5 shows several typical waveforms when the output is shorted. The inductor current only presents during retry, which prevents overdraw of the supply power.

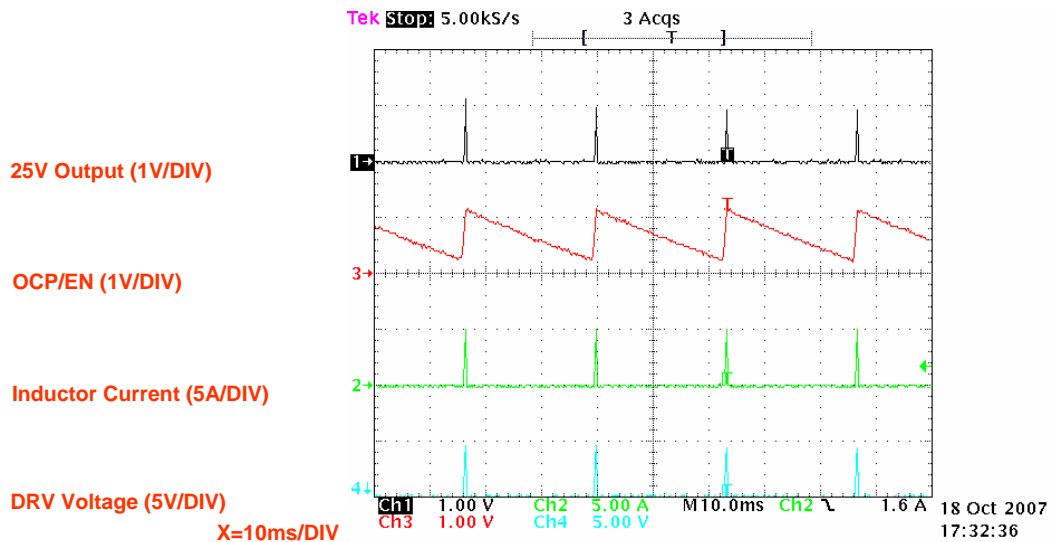

Figure 5: Typical waveforms in a boost converter under OCP when controlled by an IC with input disconnect function.

Conclusion

In this article, we described a simple structure improvement of a traditional boost converter and a simple PWM controller to achieve I/O disconnect, eliminating malfunctions when $V_{OUT} < V_{IN}$. A boost converter configured, and a controller controlled with an I/O disconnect function, provides the following benefits:

- Programmable soft turn-on for inrush current control
- Hiccup mode for over-current protection
- Complete shutdown with source-load separation
- Simple loop compensation
- Protection for power MOSFET (Q2) failure

These are important benefits for high-performance power supplies in low- to medium-power applications.

References:

- [1] Erickson, R.W. and Maksimovic, D. "Fundamentals of Power Electronics", 2ed Ed., 2001.
- [2] Semtech Corp., SC120 datasheet, Low Voltage Synchronous Boost Regulator, <http://www.semtech.com/images/datasheet/sc120.pdf>
- [3] Semtech Corp., SC440A datasheet, High Efficiency Integrated Driver for 6-Strings of 30mA LEDs, <http://www.semtech.com/images/datasheet/sc440a.pdf>
- [4] Semtech Corp., SC441A datasheet, High Efficiency Integrated Driver for 4-Strings of 150mA LEDs, <http://www.semtech.com/images/datasheet/sc441a.pdf>
- [5] Semtech Corp., SC2603A datasheet, Simple PWM Boost Converter in Small SOT23-6 Package, <http://www.semtech.com/images/datasheet/sc2603.pdf>
- [6] Semtech Corp., SC2604 datasheet, Simple PWM Boost Controller with Input Disconnect FET Drive, <http://www.semtech.com/images/datasheet/sc2604.pdf>