

Product Brief



SEMTECH POWER MANAGEMENT

Digitally Controlled EcoSpeed® DC-DC Converter

Flexible, High-Performance Solution for Complex Power Management Requirements



PWM controller with I²C interface provides ultra-fast transient response and high efficiency with the flexibility of digital control.

Description

The SC493 combines Semtech's patented⁽¹⁾ EcoSpeed® adaptive on-time (AOT) controller core with I²C configuration and diagnostics functions delivering the benefits of high-performance analog and the flexibility of digital control.

Pure analog controllers can provide high performance, but lack flexibility. Some controllers offer digital flexibility using fully digital topologies that require high-speed ADCs

and power-hungry DSPs. The SC493 wraps Semtech's best-in-class, EcoSpeed AOT core with a digital interface to deliver ultra-fast transient response, high efficiency across light to full power loads and the flexibility of digital control.

The SC493 does not require external compensation components and works with any type of output capacitor, providing a simple, flexible, space-saving and cost-effective power management solution.

SC493 – EcoSpeed PWM Controller with I²C Interface

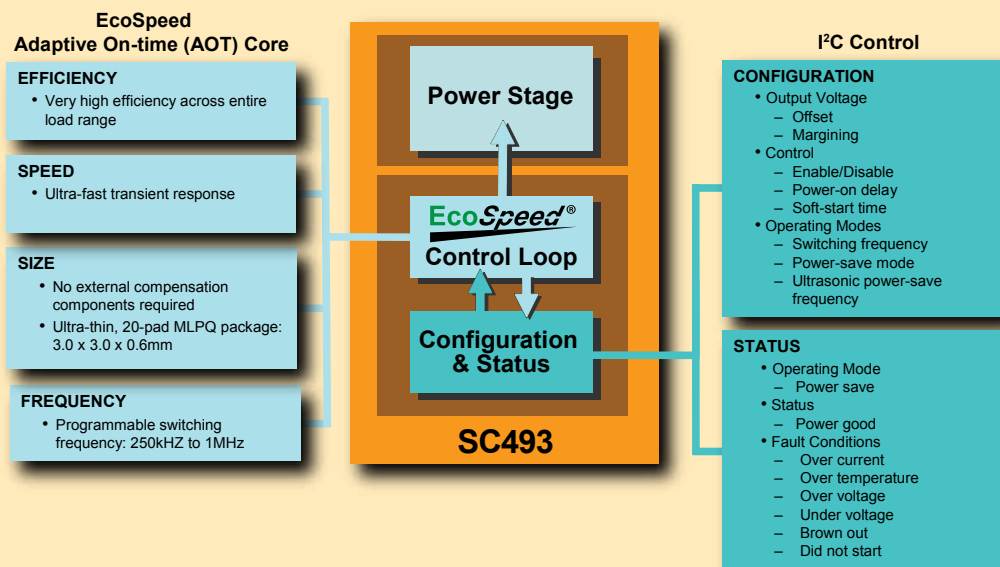

(1) U.S. Patent No. 7,714,547

Digital Voltage Margining

Many designers enhance system reliability by conducting voltage margining during the final test phase of product manufacture. Margining is achieved by raising and lowering the supply voltages to stress test the system. The SC493 enables users to digitally control margining up to $\pm 10\%$ from nominal.

Digital Output Voltage Offset Configuration

The SC493 features a separate configuration function allowing users to fine-tune the output voltage in increments of 0.75% from nominal, up to a maximum of $\pm 9\%$. This offset can be combined with the voltage margining for even greater offsets.

SC493 Features Overview

- I²C configuration control and status monitoring
- Patented adaptive on-time control architecture
 - Ultra-fast transient response
 - Pseudo-fixed switching frequency typically $\pm 15\%$ accuracy
 - Programmable switching frequency: 250kHz to 1MHz
 - Very high efficiency across the entire load range
 - No external compensation components required
- Selectable auto power-save (PSAVE)
 - Programmable ultrasonic PSAVE (UPSAVE)
 - > Eliminates audible noise during standby
 - > Provides programmable floor frequency
 - Regular PSAVE
 - > Provides up to 95% peak efficiency during light loads
- Very wide V_{IN} range: 3V to 28V
- V_{OUT} range: 0.5V to 5V
- Gate drive to FETs capable of supporting 25A loads
- Fully protected
- SmartDrive™ technology reduces EMI
- Ultra-thin, 20-pad MLPQ package – 3.0 x 3.0 x 0.6 mm

Typical Application Circuit

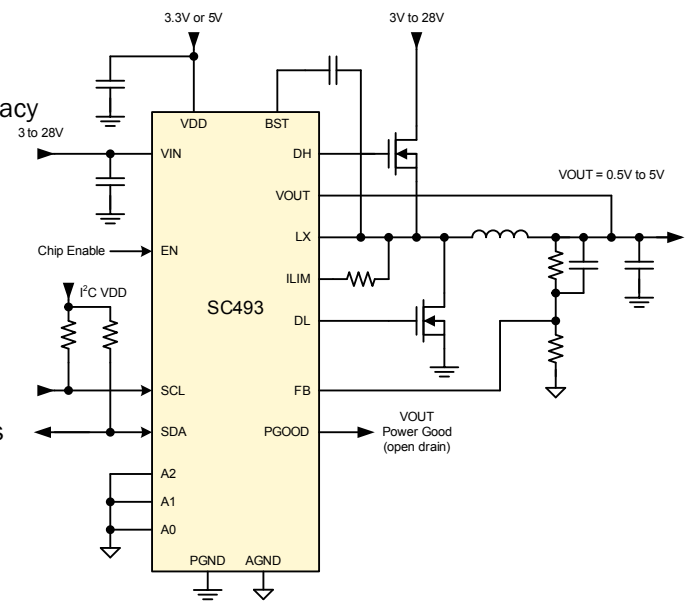

Applications

High-current, distributed main power supply rails in:

- Networking and communications equipment
- Office automation equipment
- Power supply modules
- Other embedded applications

Ordering Information

Part Number	Package	Eval Board
SC493ULTRT	MLPQ-UT-20 (3 x 3 x 0.6 mm)	SC493EVB

Pin Configuration

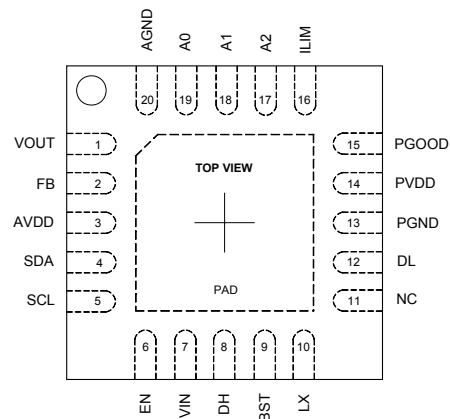

Semtech, the Semtech logo and EcoSpeed are registered marks of Semtech Corporation and SmartDrive™ is a trademark of Semtech Corporation. Semtech reserves the right to make changes to, or discontinue any products described in this document without further notice. Semtech makes no warranty, representation or guarantee, express or implied, regarding the suitability of its products for any particular purpose. I²C and the I²C bus are trademarks of NXP B.V. ©2011 Semtech Corporation. All rights reserved. SC493-AG-0411