

Improving the Accuracy of a Crystal Oscillator

1. Introduction

Short Range Devices are being implemented in various markets requiring different channel spacing and differing regulatory requirements. Narrowband applications, requiring lower bit rates and fitting into very small channel bandwidths, obviously require a tight reference oscillator precision. Wider bandwidth applications have less stringent requirements on the stability of their RF carrier. However, increasing the global precision of the system can dramatically reduce cost, processing time, or improve battery lifespan or link budget over all operating conditions. This note illustrates a few simple and efficient tricks to improve local oscillator precision and stability.

2. Crystal Precision and Stability

Due to the uniqueness of the crystal structure, the oscillator assembly itself, and a handful of other reasons, the oscillation frequency of a crystal oscillator (XO) labeled, for example, 20.0000 MHz, will never be 20.0000 MHz. Before we go through the main first order effects that cause inaccuracy to the oscillation frequency, a reminder on notations:

2.1. Parts Per Million (ppm)

Since the accuracy of the oscillation frequency of a XO is very good, the frequency error of a crystal oscillator (denoted ϵ) is expressed in ppm (parts per million). Mathematically:

$$\epsilon[\text{ppm}] = \frac{\text{ActualFrequency} - \text{TheoreticalFrequency}}{\text{TheoreticalFrequency}} \times 10^6$$

This is a convenient way of noting the frequency error, because the ppm error will remain the same if it is either measured on the reference XO, or on the output of the Radio Frequency transmitter (since a PLL acts as a simple frequency multiplier).

Let's figure out the different frequency errors brought by a XO.

2.2. Initial Error

All crystal blades are made equal. However, impurities in the crystal growth, imprecision in the cut process of the device and uneven thickness (amongst other reasons) of

the processed blade lead to slightly different nominal oscillation frequencies on a batch of crystal.

The effect is known as "frequency tolerance". It is usually specified at ambient temperature (i.e. 25 +/- 3°C).

Common frequency tolerances range from +/-5 to +/-100ppm, and this specification plays an important role in the cost of the device. Indeed getting very low tolerance crystal batches requires an expensive and time consuming sorting process. Fortunately we will see in the following sections that modern RF architectures allow for quick and inexpensive SW compensation of the crystal tolerance.

2.3. Temperature Dependency

Any crystal oscillator, even if centered at the right frequency at ambient temperature, will exhibit a temperature dependency, also called "drift".

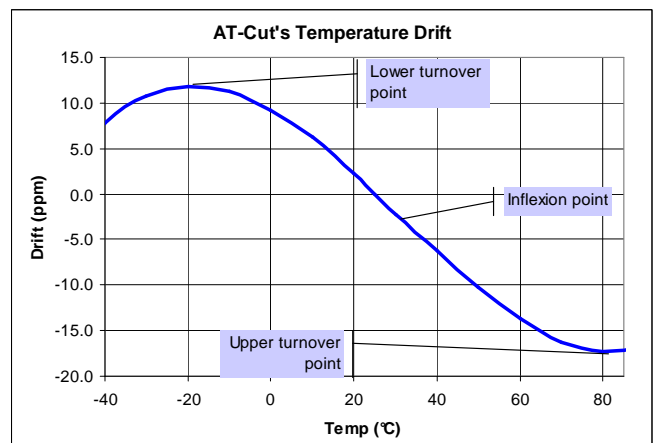

Figure 1. Typical AT-cut Temperature Curve

Most low-cost crystals exhibit an S-shape curve as shown in Figure 1. The inflexion point of this curve stands relatively close to the ambient temperature. Upper and lower turnover points are delimiting a region where the XO frequency response over temperature is almost linear, and would allow for pretty simple compensation.

2.4. Ageing

Crystals are electromechanical devices, and as such they are subject to ageing. Unfortunately, there is no simple rule to predict the ageing of a crystal, or even that of a batch of crystals. Figure 2 below (extracted from [1]) shows three devices whose behavior over time is not monotonous, which makes it almost impossible to compensate "theoretically" for any ageing effect.

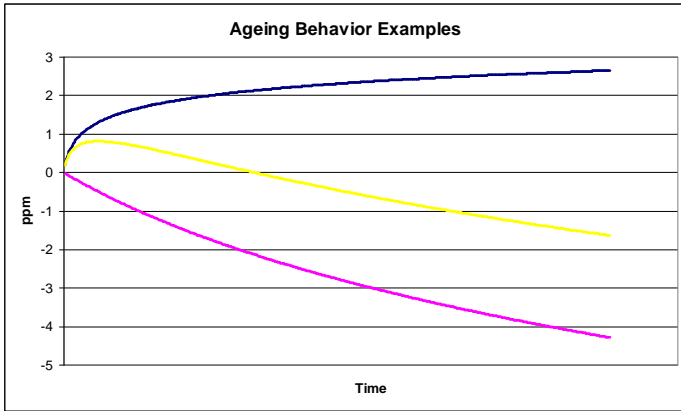

Figure 2. Ageing Behavior Examples

Crystal vendors would provide, for very frequency sensitive applications, aged devices. It can be proved that the ageing is higher during the first hours of operation. Using aged crystals will result in a lower ageing rating in ppm/year.

2.5. Trim Sensitivity

An inherent property of crystal oscillators is their trim sensitivity. As illustrated on Figure 3 below, crystals are used between their series resonance and their anti-resonance frequencies. In this parallel resonant mode the crystal should be loaded by a well defined load capacitance.

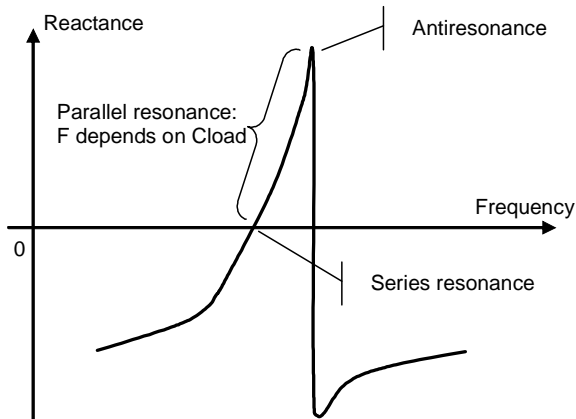

Figure 3. Crystal Reactance Plot

The oscillation frequency will depend on the load capacitance. This characteristic also known as “trim sensitivity” can be used to:

- ◆ Adjust the initial frequency error of the oscillator, by manually adjusting the load capacitance of the XO.
- ◆ Perform frequency modulation, as any change in the loading capacitor is translated into a frequency shift.

The trim sensitivity usually ranges from 10 to 20 ppm/pF. This shows that the operating frequency would slightly be affected by the drift of the loading capacitors over the temperature range.

3. Sensing the Frequency Error

Knowledge of the frequency error is the first step in attempting to correct it.

3.1. On the Production Bench

Semtech’s SX12xx family of products features transmitters, receivers and transceivers. On these devices, there are at least two different methods to measure the error of the reference oscillator.

3.1.1. Spectrum Analyzer Approach

A spectrum analyzer offers a good solution to measure the output frequency error on the RF carrier and hence, ϵ .

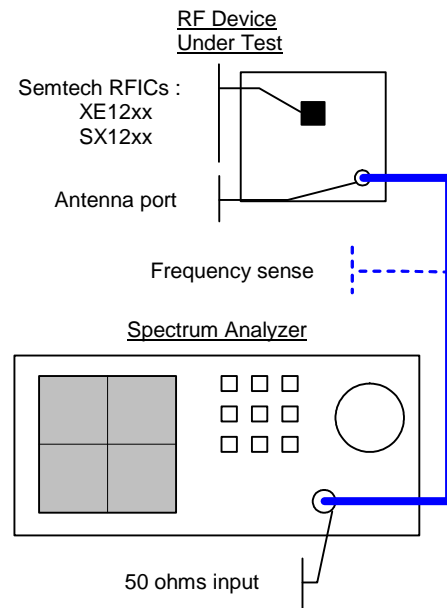

Figure 4. Spectrum Analyzer Test Setup

To obtain a good precision on the frequency measurement, the following is recommended:

- ◆ Put the device under test in continuous transmit mode, unmodulated carrier
- ◆ Select a span that is wide enough to display the carrier even for extreme frequency errors (+/-50 ppm i.e. span = 100 kHz is a convenient value).
- ◆ Select a Resolution BandWidth (RBW) that allows for a precise reading of the frequency. Usually the automatic setting of the instrument is correct.

It is then pretty easy to calculate ϵ (ppm) from the expected theoretical center frequency $F_{RFideal}$ and the actual measured frequency $F_{RFmeasured}$:

$$\epsilon[ppm] = \frac{FRF_{measured} - FRF_{ideal}}{FRF_{ideal}} \times 10^6$$

Please note that the frequency error is a signed value (frequency higher or lower than expected).

Notes: (1) On the test setup described on Figure 4, the 50 ohm cable connection can be replaced by antenna(s). The user should adjust the reference level of the spectrum analyzer accordingly.

(2) On some of the Semtech RF ICs, the unmodulated carrier can be generated at the center frequency of the channel (XE1203F, XE1205, SX1230) by disabling the modulation. On others (SX1211, SX1210, SX1212) the carrier is always offset by the frequency deviation (+ or - F_{dev} , as programmed in the transmitter register). This is to be included on the calculus of ϵ .

3.1.2. Frequency Counter Approach

With Semtech's SX12xx family of ICs, the reference oscillator output can be made available on pin CLKOUT. It is then relatively straight forward to evaluate the error of the reference oscillator:

$$\epsilon[ppm] = \frac{F_{CLKOUTmeasured} - F_{CLKOUTideal}}{F_{CLKOUTideal}} \times 10^6$$

The signal available at CLKOUT can either be the actual XO frequency, or the XO frequency divided by N (integer value)...As a ratio, ϵ can either be measured directly at the XO frequency, or after this frequency division.

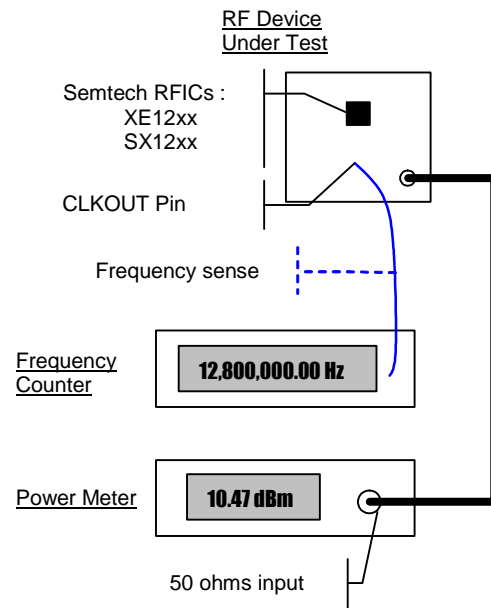

Figure 5. Frequency Counter Test Setup

3.1.3. FEI Approach

Semtech's receiver architectures offer an inexpensive alternative solution based on their FEI (Frequency Error Indicator). This block, located in the baseband section of the receiver, is able to evaluate the frequency error between a known frequency RF generator connected to the RF input (LNA port) and the Local Oscillator (LO) of the device. The FEI result can be retrieved in a control register of the device, through the SPI interface.

This method is illustrated on Figure 6.

The FEI result is usually expressed in kilohertz (kHz). This error is relative to the RF frequency, therefore ϵ can be computed as follows:

$$\epsilon[ppm] = \frac{FEI[kHz]}{FRF_{ideal}[Hz]} \times 10^3$$

Note: The FEI is a signed result, as the frequency offset can again be positive or negative.

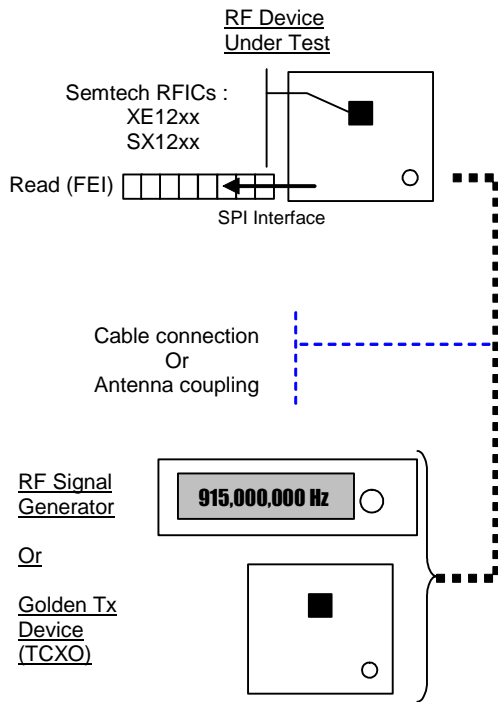

Figure 6. FEI-based Test Setup

3.2. Field Measurements

As seen in section 2, some of the frequency errors are due to the field conditions and environment that the device is operating. Hence there may be a requirement to measure the frequency error while the RF application is running in the field. It should be noted that field frequency alignment measurements are generally relative rather than absolute measurements, since the frequency error of the module will be measured relative to another unit in the field.

3.2.1. Remote Frequency Error Sense

On some specific systems, a central point - or Master unit - would be exchanging information with a pool of nodes. This is illustrated in the example of Figure 7. The central device, whose cost is less sensitive, can embed a precise frequency reference such as a TCXO (Temperature Compensated XTAL Oscillator). The end points of this star network (sensors and actuators) can utilize the precision of the Master unit to run their FEI and evaluate their frequency offset.

3.2.2. Local Frequency Error Estimate

As the temperature dependency of the crystal follows mathematical rules, the frequency drift of a remote point in an RF system can be computed readily. It simply requires

that the application embeds a temperature sensing unit. Several choices:

- ◆ Integrated temperature sensor: this is the simplest solution. Several vendors propose stand alone temperature sensing units that are calibrated, and offer temperature readings down to an accuracy of +/-1°C. This is more than enough to compensate for the temperature drift effect of common XTAL oscillators.
- ◆ Temperature coefficient device + ADC: if the processor in the application embeds an ADC, a simple NTC (Negative Temperature Coefficient) or PTC (Positive Temperature Coefficient) device can be used to sense the surrounding temperature. The default accuracy of such systems would be quite poor, but running a calibration routine will help getting the required precision.

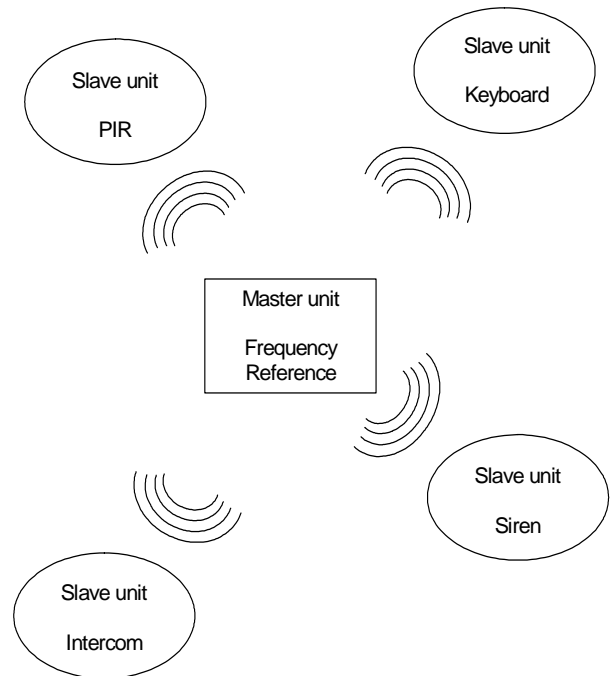

Figure 7. Alarm System Example

4. Frequency Error Compensation

Section 3 provides an overview of the possible methods to evaluate the frequency error ϵ of an RF node, either in production or on the field. Section 4 proposes options to compensate it.

4.1. Fractional-N PLL Products

Several devices in Semtech's broad range of transmitters, transceivers and receivers feature a built-in frequency synthesizer based on a fractional-N (Frac-N) Phase Lock Loop (PLL). We won't discuss here the advantages of this type of architecture, but all we need to know at this point is the following: the resolution of the Frac-N PLL is constant

ADVANCED COMMUNICATIONS & SENSING

FINAL

Application Note

along its frequency range, typically in the hundreds of hertz. We can call this PLL_Step.

Hence, it is pretty easy for the user who knows the frequency error ϵ , to convert it and shift the Local Oscillator frequency accordingly.

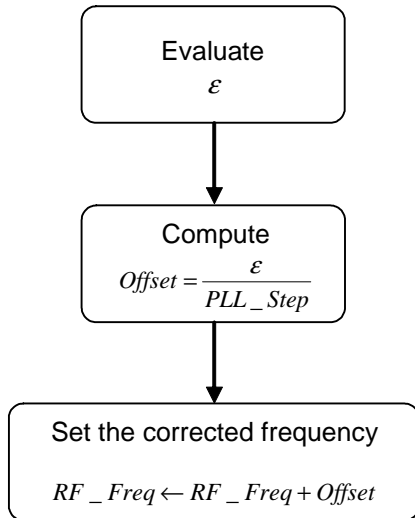

Figure 8. Error Compensation on Frac-N Products

4.1.1. XE1203F and XE1205

On these two products, the synthesizer resolution, PLL_Step, is 501 Hz. The RF frequency RF_Freq is actually controlled in a 16-bits register named Freq_LO. Note that this register is represented as two's complement, i.e. Freq_LO = 0 yields the center frequency of the selected band, while positive or negative frequency offsets should be computed as two's complement.

4.1.2. AFC in the XE1205

The process described above can even be made automatically by using the internal Automatic Frequency Control block (AFC) of the XE1205. It automatically performs the sequence described on Figure 8, and the evaluation of ϵ is carried out by the FEI. Please refer to the XE1205 datasheet for guidance on its use.

4.1.3. SX1230

This newer product incorporates a Frac-N PLL with a resolution of 61 Hz. Unlike the XE12xx products, the actual carrier frequency FRF is a direct factor if the Freq_RF register, coded on 19 bits:

$$F_{RF}[Hz] = Freq_{RF} \times 61Hz$$

4.2. Integer-N PLL Products

Integer-N types of PLL remain a good choice for some products, especially when the power consumption needs to be the lowest and when the PLL resolution (i.e. the closest distance in Hz between two synthesizable frequencies) is not a major concern. This is the case for wider band products, where the targeted frequency precision range is in the tens of ppm.

The SX1210, SX1211, SX1212 and SX1213 include such a PLL, which enables them to achieve their incredible 3 mA typical receive current. Table 1 shows all the synthesizable frequencies between 912.990 MHz and 913.010 MHz. Two comments:

- ◆ The average PLL resolution is quite small (typically 2 kHz over the whole band).
- ◆ But the PLL resolution is not constant, and not predictable.

FRF(MHz)	Step
[MHz]	[kHz]
912.9913	-
912.9931	1.8
912.9941	1.0
912.9951	1.0
912.9962	1.1
912.9974	1.2
912.9987	1.3
913.0000	1.3
913.0014	1.4
913.0030	1.5

Table 1 Integer-N PLL Step Illustration

To aid designers with frequency calculation, Semtech provides the "SX1211 PLL Frequency Calculator". This software is available from the Semtech website.

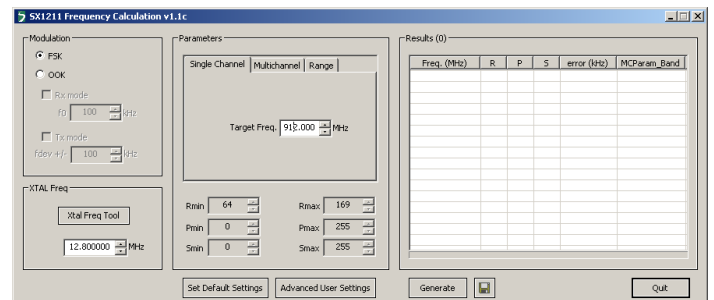

Figure 9. PLL Frequency Calculator Preview

ADVANCED COMMUNICATIONS & SENSING

FINAL

Application Note

This tool can be used to compensate for the XO's initial frequency error and frequency drifts. The input parameters are:

- ◆ Target Freq: Center of the channel, in MHz, in single channel mode
- ◆ FSK / OOK: Selects the type of modulation of the application
- ◆ XTAL Freq: Actual XO oscillation frequency

This software can be used to compensate for the different frequency errors discussed in section 2.

4.2.1. Correction at Ambient Temperature

For every device, the user should simply replace the theoretical reference (XO) frequency, i.e. 12.8000 MHz, by its actual value. Refer to section 3 for guidelines on the evaluation of ϵ .

Example:

The following example assumes a population of 5 units, with a different reference frequency error at ambient temperature. The target channel frequency is 914.25 MHz, FSK transmission.

ϵ	Theoretical XO Frequency	Actual XO Frequency	R	P	S	RF error	Corrected ϵ
[ppm]	[MHz]	[MHz]	Decimal			[kHz]	[ppm]
0	12.800000	12.8000000	95	80	20	0.000	0.0
-15	12.800000	12.7998080	105	88	55	0.437	0.5
12	12.800000	12.8001536	134	113	21	0.971	1.1
5	12.800000	12.8000640	138	116	50	-0.824	-0.9
8	12.800000	12.8001024	136	114	73	-0.350	-0.4
-7	12.800000	12.7999104	99	83	49	-0.400	-0.4

The table above shows that, for units whose frequency error ranges from -15 to +12 ppm at ambient temperature, an alternative set of {R,P,S} values can be found to bring back the tolerance to less than +/- 2ppm.

Note: The "SX1211 PLL Frequency Calculator" software is based on a dll, that can be used either with the provided GUI, or called as a function in any automated test equipment. Please see the associated documentation.

4.2.2. Correction over Temperature

A good knowledge of both the temperature and the temperature dependency of the crystal unit is a must. Along with the PLL Frequency Calculator, the following type of look-up table can be built:

Temperature	ϵ	Actual XO Frequency	R	P	S	RF error	Corrected ϵ
[°C]	[ppm]	[MHz]	Decimal			[kHz]	[ppm]
-40	7.8	12.8000992	91	76	66	0.564	0.6
-30	10.8	12.8001376	134	113	21	-0.172	-0.2
-20	11.8	12.8001504	134	113	21	0.742	0.8
-10	11.3	12.8001440	134	113	21	0.285	0.3
0	9.3	12.8001184	136	114	73	0.793	0.9
10	6.3	12.8000800	138	116	50	0.318	0.3
20	2.3	12.8000288	142	120	4	1.008	1.1
25	0.0	12.8000000	95	80	20	0.000	0.0
30	-2.3	12.7999712	97	81	72	1.004	1.1
40	-6.3	12.7999200	99	83	49	0.286	0.3
50	-10.3	12.7998688	101	85	26	-0.548	-0.6
60	-13.8	12.7998240	156	131	68	-0.151	-0.2
70	-16.3	12.7997920	105	88	55	-0.706	-0.8
80	-17.3	12.7997792	160	135	22	0.067	0.1
90	-16.8	12.7997856	160	135	22	0.525	0.6

Table 2 Temperature Compensation Look-up Table

The SX1211 PLL Frequency Calculator takes the frequency error ϵ at each temperature as a parameter (the corresponding actual XO frequency indeed), to provide an alternate {R,P,S} set that will compensate for the temperature drift of the XO. figure 10 below shows the original and corrected error curves:

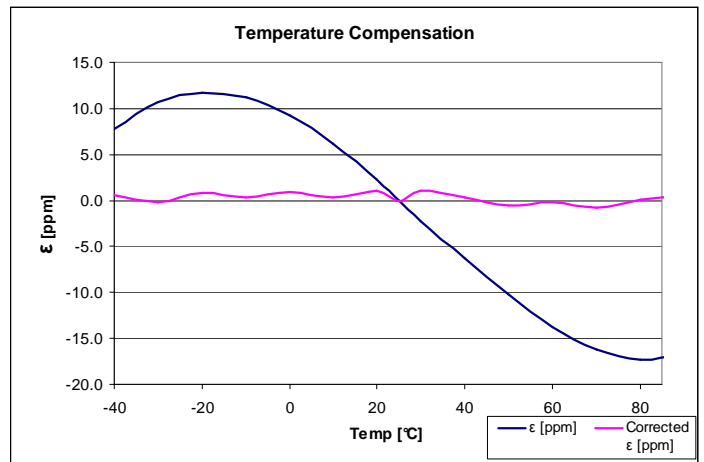

Figure 10. Temperature Compensated XO Response

Notes: (1) the size of the look-up table containing the {R,P,S} triplets should be adapted to the wanted frequency precision, and to the precision of the temperature sensor

(2) Multi-channel applications should store one look-up table per channel, to allow for temperature compensation on any of the frequencies used.

5. Conclusion

Adding precision to a radio frequency link implemented using Semtech's range of RF devices is aided by features sets of these devices. One of the key points is to identify the required precision (mainly dependent upon the available

channel size), and the type of IC that is used (Fractional or Integer-N based PLL synthesizers).

6. References

[1] Quartz Crystal Resonators and Oscillators For Frequency Control and Timing Applications A Tutorial, by John R. Vig, January 2000.

© Semtech 2009

All rights reserved. Reproduction in whole or in part is prohibited without the prior written consent of the copyright owner. The information presented in this document does not form part of any quotation or contract, is believed to be accurate and reliable and may be changed without notice. No liability will be accepted by the publisher for any consequence of its use. Publication thereof does not convey nor imply any license under patent or other industrial or intellectual property rights. Semtech assumes no responsibility or liability whatsoever for any failure or unexpected operation resulting from misuse, neglect improper installation, repair or improper handling or unusual physical or electrical stress including, but not limited to, exposure to parameters beyond the specified maximum ratings or operation outside the specified range.

SEMTECH PRODUCTS ARE NOT DESIGNED, INTENDED, AUTHORIZED OR WARRANTED TO BE SUITABLE FOR USE IN LIFE-SUPPORT APPLICATIONS, DEVICES OR SYSTEMS OR OTHER CRITICAL APPLICATIONS. INCLUSION OF SEMTECH PRODUCTS IN SUCH APPLICATIONS IS UNDERSTOOD TO BE UNDERTAKEN SOLELY AT THE CUSTOMER'S OWN RISK. Should a customer purchase or use Semtech products for any such unauthorized application, the customer shall indemnify and hold Semtech and its officers, employees, subsidiaries, affiliates, and distributors harmless against all claims, costs damages and attorney fees which could arise.

Contact information

Semtech Corporation Advanced Communications & Sensing Products

Taiwan	Tel: 886-2-2748-3380 Fax: 886-2-2748-3390	Switzerland	Tel: 41-32-729-4000 Fax: 41-32-729-4001
Korea	Tel: 82-2-527-4377 Fax: 82-2-527-4376	United Kingdom	Tel: 44-1794-527-600 Fax: 44-1794-527-601
Shanghai	Tel: 86-21-6391-0830 Fax: 86-21-6391-0831	France	Tel: 33-(0)169-28-22-00 Fax: 33-(0)169-28-12-98
Japan	Tel: 81-3-6408-0950 Fax: 81-3-6408-0951	Germany	Tel: 49-(0)8161-140-123 Fax: 49-(0)8161-140-124