

Product Brief



SEMTECH WIRELESS & SENSING PRODUCTS

XM1205

True RF™ 433/868/915 MHz

Transceiver board for narrow & wide band applications

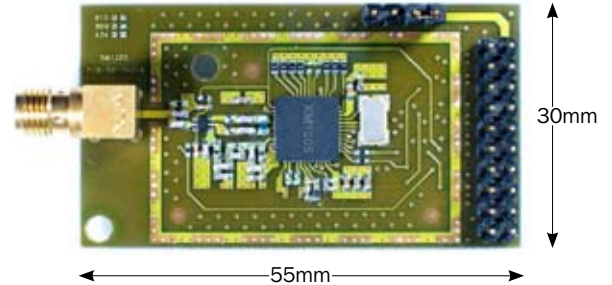

WORLD'S HIGHEST LINK BUDGET TRANSCEIVER

General Description:

The XM1205 TrueRF transceiver module is designed to be both cost effective and have low power consumption. Based on the highly integrated XE1205 TrueRF chip, the RF module has a direct digital interface for data, RSSI output, On-Chip AFC (Automatic Frequency Control), FEI (Frequency Error Indicator) output and antenna Rx/Tx switch control. As with the XE1205, the XM1205 transceiver module offers the unique advantage of narrow-band and wide-band communication.

The XM1205 is optimized for high data rates up to 152.34 kbit/s, this without the need to modify the number or parameters of the external components. The XM1205 is optimized for low power consumption while offering high RF output power and exceptional receiver sensitivity. The device is suitable for circuit applications which have to satisfy either the European (ETSI-300 220-1) or the North American (FCC part 15.247 and 15.249) regulatory standards. The XM1205 transceiver module allows straightforward evaluation or application development.

Ordering Information:

Part	Pin-package
XM1205-C915	20 Pin DIL Header
XM1205-C868	20 Pin DIL Header
XM1205-C433	20 Pin DIL Header

Key Product Features:

- Direct digital interface
- Rx / Tx switch on board
- Frequency synthesizer step: 500 Hz
- Narrow band operation: 25 kHz channels for data rates up to 4.8 kbit/s, NRZ coding. Transmitter prefiltering to enable adjacent channel power below -37 dBm at 25 kHz
- Output power is programmable: up to 15 dBm
- High reception sensitivity: down to -116 dBm at 4.8 kbit/s, -121 dBm at 1.2 kbit/s
- Data rate up to 152.3 kbit/s
- Low Power consumption: RX=14 mA; TX=62 mA @15 dBm (typical)
- Supply voltage range from 2.4V - 3.6V
- 16 byte FIFO for transmits and receives data buffering and transfer via SPI bus.
- Incoming data pattern recognition
- Synchronized clock output
- Bit Synchronizer
- RSSI (Received Signal Strength Indicator)
- On-Chip AFC (Automatic Frequency Control)
- FEI (Frequency Error Indicator)

Product Brief

XM1205 True RF™ Module

XM1205 Block Diagram

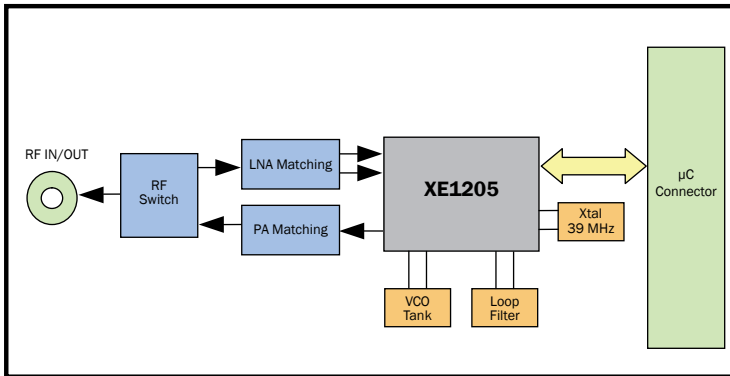

Pin Configurations:

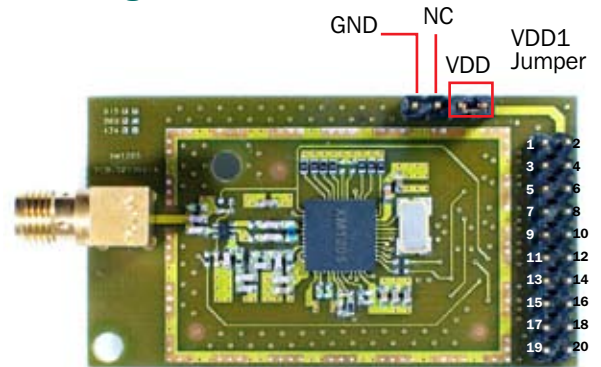

Typical Application / Connection Example (Buffer Mode)

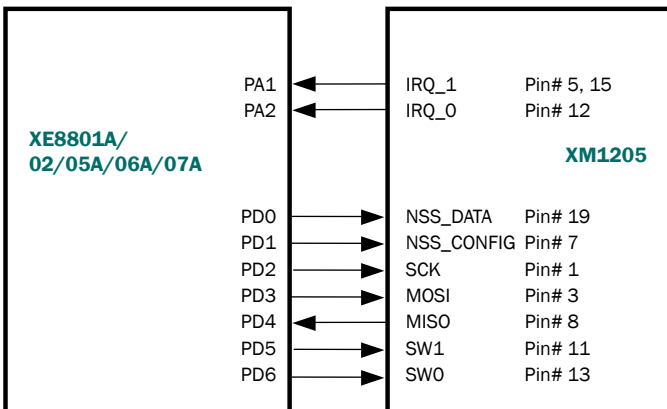

I/O Pin	Description
1	SCK: SPI Bus Serial Clock (Input)
2	VDD*
3	MOSI: SPI Bus Master Output Slave Input (Input)
4	GND*
5, 15	IRQ_1: Interrupt (Output)
7	NSS_CONFIG: SPI Select Configuration
8	MISO: SPI Bus Master Input Slave Output (Output)
9	CLKOUT: Reference Frequency Output Clock (Output)
11	SW(0): Transceiver Mode Select (Input/Output)
12	IRQ_0: Interrupt (Output)
13	SW(1): Transceiver Mode Select (Input/Output)
17	DATA: Tx Input Data/Rx output Data (Input/Output)
19	NSS_DATA: SPI Bus DATA (Input/Output)
6, 10, 14, 16, 18, 20	N/C

* For convenience, the XM1205 can be supplied through the separate VDD and GND pins. In this case, the two supply lines of the 20-pin connector should not be used, and the VDD1 jumper should be removed.

Visit our website to locate most current product specifications, datasheets and contact information for your local Semtech Field Applications Engineer.

WWW.SEMTECH.COM