TN8000.06

Technical Note

XE8000 Interleaved Interrupts Handling

Introduction

This application note concerns all the XE8000 products with software using interleaved interrupts. CoolRIDE C-compiled software does not include interleaved interrupts.

Abstract

The clearing of the General Interrupt Enable (GIE) bit in the status register may not be executed properly whenever an interrupt occurs at the same time the clear instruction is executed. This may lead to inconsistent behavior. This application note provides a way to overcome the issue by software.

Situation Description

The following timing diagram illustrates the issue:

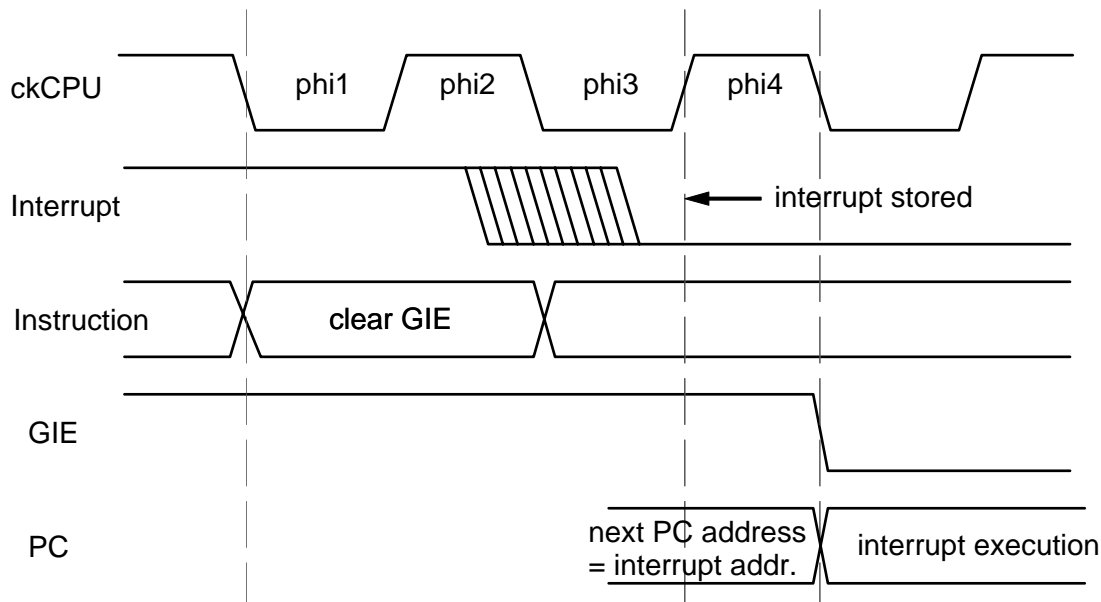

Interrupt requests are taken into account at the next rising edge of the clock, provided the GIE flag is set. The clearing of the GIE flag to disable any interrupt needs some time to take effect, typically GIE will be zero at the falling edge of the phi4 phase and it is the time when the interrupt routine starts to execute. Interrupt requests may therefore be taken into account before the instruction that clears the GIE actually takes effect.

Other concerned situations are when interleaved interrupts are used or when some critical part of an interrupt code has to be protected from interrupts. In this case we have a sequence like the following:

```

_int:
    ... ; GIE is set, interrupts may occur
    _non_critical_section:
        ... ; some instructions
        CLRB stat, #5 ; clear GIE
    _critical_section:
        ... ; interrupts should be disabled

```

A problem occurs when another interrupt request occurs during the time the "clear GIE" instruction is executed. The interrupt request is anyway validated as the GIE flag is not yet cleared. As a result, when returning from this

interrupt with the RETI instruction, the GIE flag is set. The critical section of the first interrupt is therefore no more protected and the end behavior may be different from the case when the second interrupt occurs later.

Solution

It is suggested to wait until the GIE flag is actually cleared before handling the critical section. Here is an assembly code fragment that illustrates the workaround:

```

_int:
        SETB          stat, #5      ; enable GIE
        ...
        _noncritical_section:
        ...
        _critical_section:
        _check_GIE:
        CLR B        stat, #5      ; clear GIE
        TST B        stat, #5      ; check GIE
        JZ C         _check_GIE
        ...
        RETI
  
```

C code

Note that a C program do not have interleaved interrupts, unless assembly instructions are explicitly included with the asm instruction. In that case, the workaround still applies.

© Semtech 2006

All rights reserved. Reproduction in whole or in part is prohibited without the prior written consent of the copyright owner. The information presented in this document does not form part of any quotation or contract, is believed to be accurate and reliable and may be changed without notice. No liability will be accepted by the publisher for any consequence of its use. Publication thereof does not convey nor imply any license under patent or other industrial or intellectual property rights. Semtech. assumes no responsibility or liability whatsoever for any failure or unexpected operation resulting from misuse, neglect improper installation, repair or improper handling or unusual physical or electrical stress including, but not limited to, exposure to parameters beyond the specified maximum ratings or operation outside the specified range.

SEMTECH PRODUCTS ARE NOT DESIGNED, INTENDED, AUTHORIZED OR WARRANTED TO BE SUITABLE FOR USE IN LIFE-SUPPORT APPLICATIONS, DEVICES OR SYSTEMS OR OTHER CRITICAL APPLICATIONS. INCLUSION OF SEMTECH PRODUCTS IN SUCH APPLICATIONS IS UNDERSTOOD TO BE UNDERTAKEN SOLELY AT THE CUSTOMER'S OWN RISK. Should a customer purchase or use Semtech products for any such unauthorized application, the customer shall indemnify and hold Semtech and its officers, employees, subsidiaries, affiliates, and distributors harmless against all claims, costs damages and attorney fees which could arise.

Contact Information

Taiwan	Tel: 886-2-2748-3380 Fax: 886-2-2748-3390	Switzerland	Tel: 41-32-729-4000 Fax: 41-32-729-4001
Korea	Tel: 82-2-527-4377 Fax: 82-2-527-4376	United Kingdom	Tel: 44-1794-527-600 Fax: 44-1794-527-601
Shanghai	Tel: 86-21-6391-0830 Fax: 86-21-6391-0831	France	Tel: 33-(0)169-28-22-00 Fax: 33-(0)169-28-12-98
Japan	Tel: 81-3-6408-0950 Fax: 81-3-6408-0951	Germany	Tel: 49-(0)8161-140-123 Fax: 49-(0)8161-140-124

Semtech International AG is a wholly-owned subsidiary of Semtech Corporation, which has its headquarters in the U.S.A