TN1202.04

Technical Note

XE1202 to XE1202A TrueRF™ migration

1 INTRODUCTION

This technical note provides the information about the main differences between the XE1202 and the new XE1202A TrueRF™ circuits. It also explains what has to be done at the application level to switch from one circuit to the other.

2 XE1202A TRUERF™ BENEFITS

- Full FCC/ETSI compliancy without a SAW filter
- Unconditional stability even at 15 dBm output power
- Improved transmission efficiency if the SAW filter is omitted (no filter insertion loss)

3 XE1202A TRUERF™ PART NUMBERING

The XE1202A TrueRF™ version part number is XE1202AI027. The 'non TrueRF™ version part number is XE1202I027. Please contact XEMICS technical support if in doubt.

4 PCB MIGRATION

Because the XE1202A TrueRF™ is pin-compatible with the XE1202, PCB layout changes are required only if the SAW filter is omitted (substitution with an L-C filter is required). Clients deciding not to change the PCB layout can use the XE1202A TrueRF™ and keep the SAW filter.

4.1 PIN NAME CHANGE

Pin 11, TVCO connected to ground in the previous version of the chip becomes now VSSP (VSS for the power amplifier) connected to ground. No PCB layout modification is necessary for this.

4.2 VCO TANK

The tank of the VCO can be implemented with one inductor in parallel with one capacitor, as in the previous version of the XE1202. The values for these components have to be changed when using the XE1202A TrueRF™. The characteristics of the external tank components must be as follows:

Name	Typical Value for 434 MHz	Typical Value for 868 MHz	Typical Value for 915 MHz	Tolerance
CV1	NC	NC	NC	± 5%
LV1	39 nH	6.8 nH	5.6 nH	± 2%

The values above are typical and may differ for different PCB layouts.

For 915 MHz and 869 MHz frequency bands the use of the external capacitor CV1 should be avoided. The value of the inductor LV1 and its position (between the two footprints) should be changed to centre the VCO tuning range. Depending on the minimum supply voltage available, the VCO tuning voltage, V_{lfb}, should be centred as follows:

Minimum supply voltage	Typical V _{lfb} for 434 MHz	Typical V _{lfb} for 868 MHz	Typical V _{lfb} for 915 MHz
V _{DDmin} = 2.7 V	0.9 V	1.2 V	1.1 V
V _{DDmin} = 2.4 V	0.8 V	1.1 V	1.0 V

4.3 LOOP FILTER OF THE FREQUENCY SYNTHESIZER

The loop filter of the frequency synthesizer is shown below:

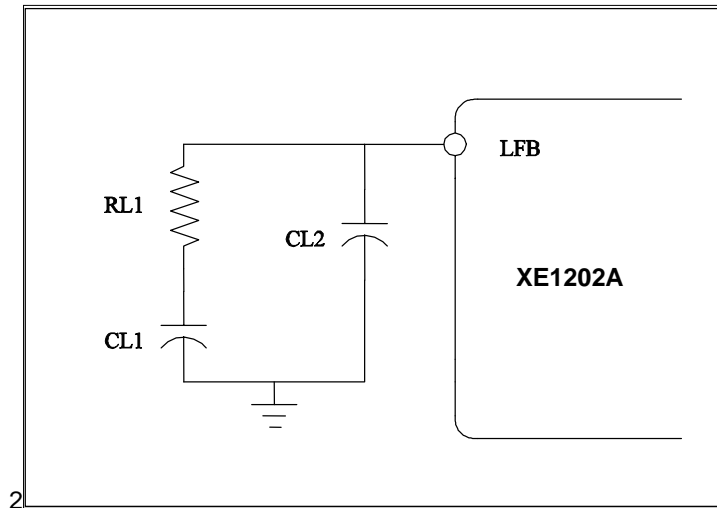

Figure 1: Loop filter of the frequency synthesizer.

The XE1202A TrueRF™ VCO has an increased K_{vco} . So the loop filter components values should be changed accordingly. The recommended values are given in the table below.

Name	Typical Value for 434 MHz	Typical Value for 868 MHz	Typical Value for 915 MHz	Tolerance
CL1	22 nF	22 nF	22 nF	± 5%
CL2	1 nF	1 nF	1 nF	± 5%
RL1	560Ω	470Ω	470Ω	± 5%

4.4 MATCHING NETWORK OF THE TRANSMITTER

The optimum load impedances for 15 dBm at the three main frequencies are given in the following table.

	434 MHz	868 MHz	915 MHz
PA optimum load	66 – 5j	66 + 14j	64 + 13j

The schematic of the recommended matching network at the output of the transmitter is given on the next page. The two Π -sections are used to provide harmonic filtering to pass FCC and ETSI regulations with sufficient margin.

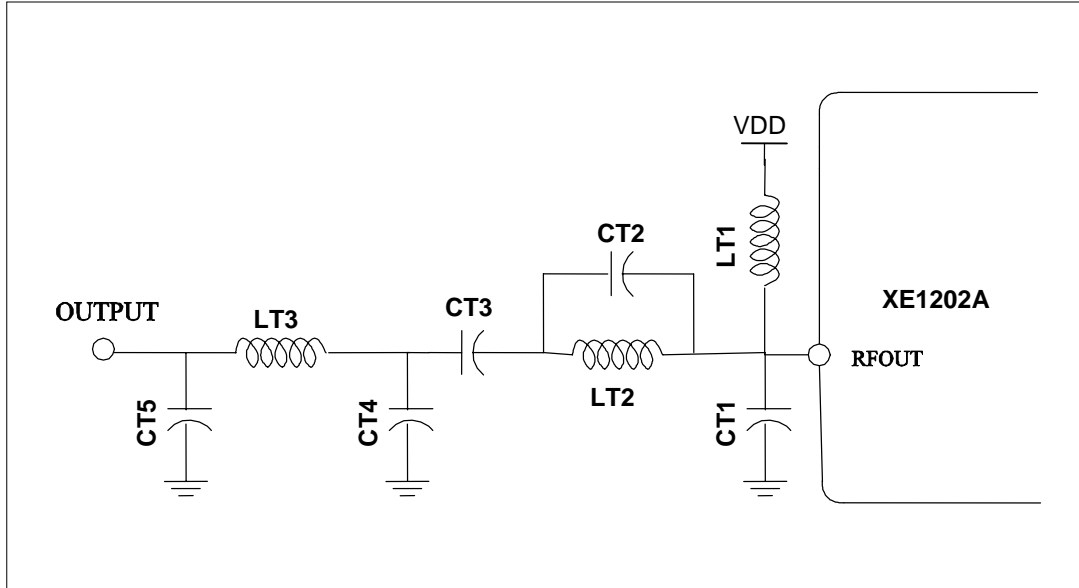

Figure 2: Transmitter output network.

The typical component values of this matching circuit are given below.

Name	Typical Value for 434 MHz	Typical Value for 868 MHz	Typical Value for 915 MHz	Tolerance
CT1	6.8 pF	1.5 pF	1.8 pF	± 5%
CT2	1.0 pF	0.56 pF	NC	± 5%
CT3	22 pF	15 pF	33 pF	± 5%
CT4	6.8 pF	3.3 pF	3.3 pF	± 5%
CT5	4.7 pF	2.2 pF	2.2 pF	± 5%
LT1	33 nH	39 nH	47 nH	± 5%
LT2	22 nH	10 nH	10 nH	± 5%
LT3	22 nH	8.2 nH	8.2 nH	± 5%

5 REGISTER CONFIGURATION

There is no change in the way of configuring the circuit. All the settings used for the XE1202 can be left unchanged in the XE1202A TrueRF™.

6 CONCLUSIONS

This application note describes the necessary changes when migrating from the existing XE1202 to the XE1202A TrueRF™. PCB layout changes are necessary only when removing the SAW filter. If the SAW filter is retained then only some component values should be changed, as described above.

© Semtech 2006

All rights reserved. Reproduction in whole or in part is prohibited without the prior written consent of the copyright owner. The information presented in this document does not form part of any quotation or contract, is believed to be accurate and reliable and may be changed without notice. No liability will be accepted by the publisher for any consequence of its use. Publication thereof does not convey nor imply any license under patent or other industrial or intellectual property rights. Semtech. assumes no responsibility or liability whatsoever for any failure or unexpected operation resulting from misuse, neglect improper installation, repair or improper handling or unusual physical or electrical stress including, but not limited to, exposure to parameters beyond the specified maximum ratings or operation outside the specified range.

SEMTECH PRODUCTS ARE NOT DESIGNED, INTENDED, AUTHORIZED OR WARRANTED TO BE SUITABLE FOR USE IN LIFE-SUPPORT APPLICATIONS, DEVICES OR SYSTEMS OR OTHER CRITICAL APPLICATIONS. INCLUSION OF SEMTECH PRODUCTS IN SUCH APPLICATIONS IS UNDERSTOOD TO BE UNDERTAKEN SOLELY AT THE CUSTOMER'S OWN RISK. Should a customer purchase or use Semtech products for any such unauthorized application, the customer shall indemnify and hold Semtech and its officers, employees, subsidiaries, affiliates, and distributors harmless against all claims, costs damages and attorney fees which could arise.

Contact Information

Semtech Corporation
Wireless and Sensing Products Division
200 Flynn Road, Camarillo, CA 93012
Phone (805) 498-2111 Fax : (805) 498-3804