

SX1701 – Datasheet

Highly linear wideband LNA

Multi-channel, single-ended to differential conversion

GENERAL DESCRIPTION

The SX1701 is an integrated LNA operating over a wide frequency range from 40 MHz to 2.5 GHz. It is optimized for high OIP2 and OIP3 with minimum current consumption. It also performs a single-ended to differential conversion.

Three independent output channels are available and the gain of each may be adjusted independently.

APPLICATIONS

- Digital Set Top Boxes (Satellite and Terrestrial)
- CATV Distribution Systems
- Active Splitter
- Data Communications Systems
- Active Balun

KEY PRODUCT FEATURES

- Single-ended input / Triple differential outputs
- Independent programmable gain for each channel: 6, 12 and 18 dB
- High Linearity: OIP2 of 57 dBm and OIP3 of 22 dBm
- Noise Figure of 7 dB
- 75 Ω Input impedance
- 100 Ω differential output impedance
- Current consumption of 130 mA with one channel enabled
- ESD protection (Normal ESD handling procedures should be observed)
- Very small package: MLPQ-16, 4 mm x 4 mm (equivalent to QFN-16, 4 mm x 4 mm)

ORDERING INFORMATION

Part number	Temperature range	Package
SX1701I085TRT	-40 °C to +85 °C	Lead Free MLPQ-16

Note: This device is WEEE and RoHS compliant.

TYPICAL APPLICATION

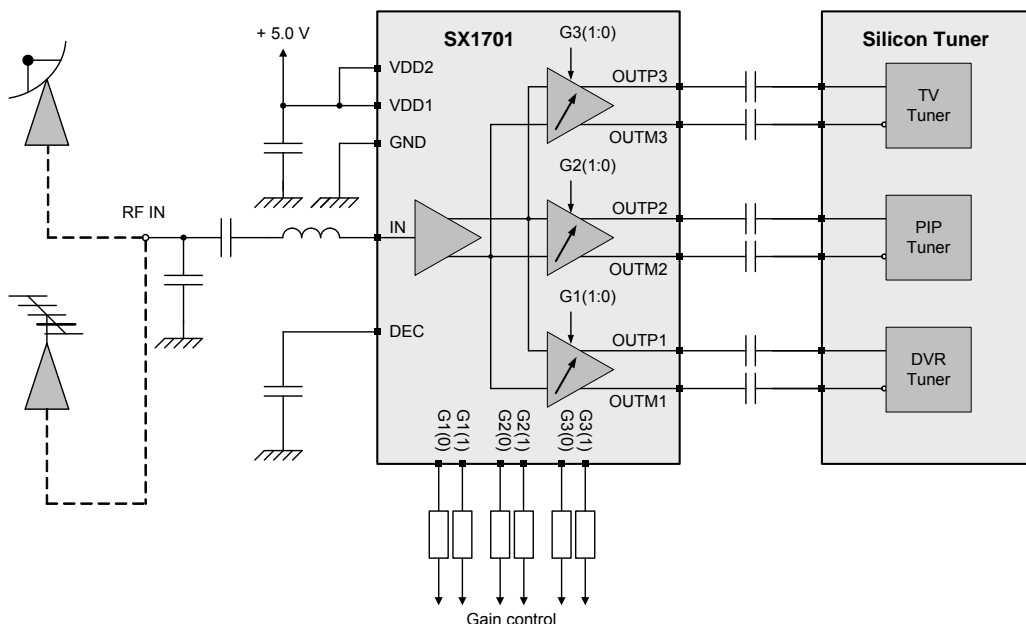

TABLE OF CONTENTS

1	Simplified Block Diagram	3
2	Pin Description	4
2.1.1	Pin Connections	4
2.1.2	Gain Control Pins	4
3	Electrical Characteristics	5
3.1	Absolute Maximum Ratings	5
3.2	Specifications	5
3.2.1	Operating Range.....	5
3.2.2	Electrical Specifications	6
3.3	Typical Operating Characteristics.....	7
4	Application Information	9
5	Application Example	10
5.1	Single-Ended Input to Dual Differential Outputs with Loop-through Single-Ended Output	10
6	Package Outline Drawing	11
7	Marking Information	11
8	Land Pattern Drawing	12

1 SIMPLIFIED BLOCK DIAGRAM

The simplified block diagram of the SX1701 is illustrated below in Figure 1.

The amplifier comprises two main stages. The first stage is common to all channels and performs the single-ended to differential conversion. The second stage, duplicated for all channels, is implemented as two cascaded stages and performs independently the gain control for each channel.

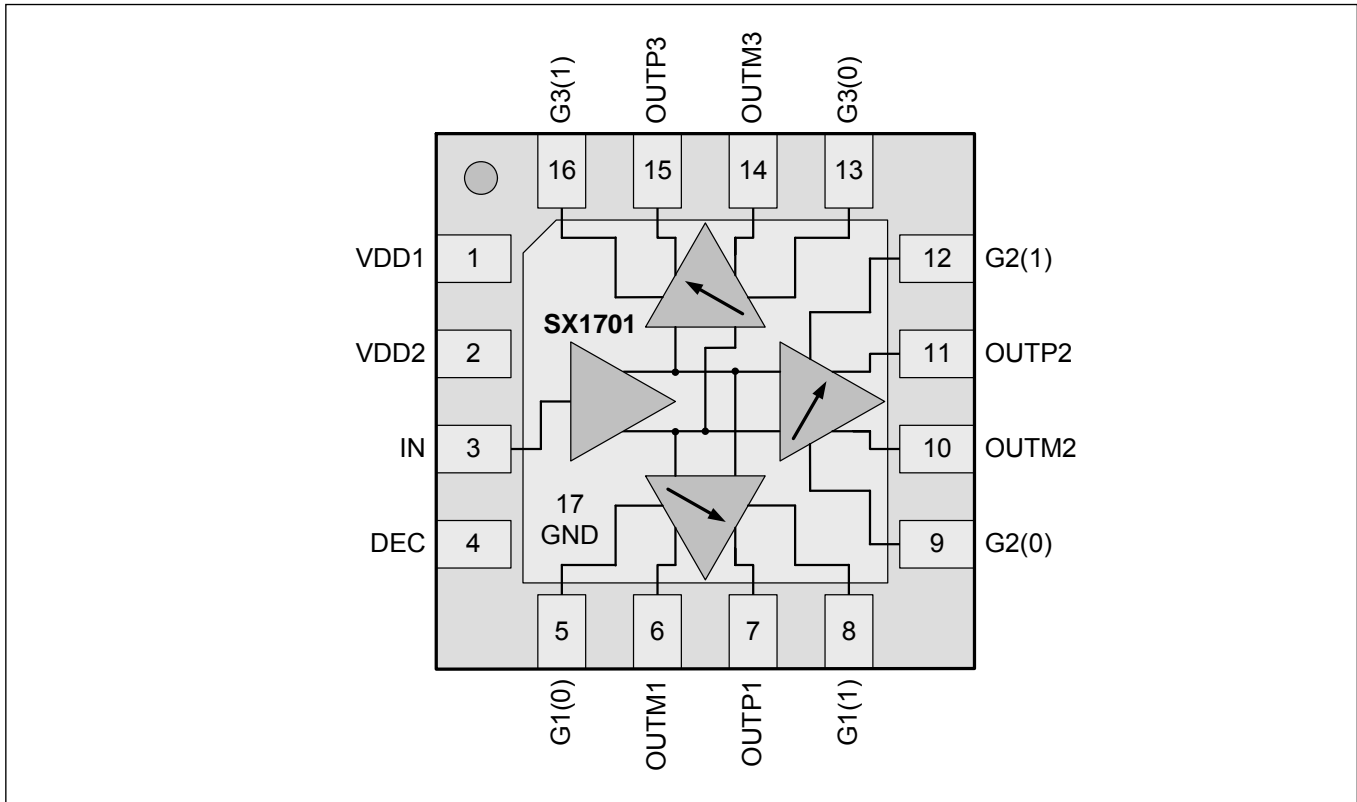

Figure 1. Simplified block diagram of the SX1701.

2 PIN DESCRIPTION

2.1.1 Pin Connections

The pin description of the SX1701 is given in Table 1.

Number	Name	Type	Description
1	VDD1	Input	Supply voltage
2	VDD2	Input	Supply voltage
3	IN	Input	LNA input
4	DEC	Input	Decoupling capacitor
5	G1(0)	Input	Control of the 1st channel
6	OUTM1	Output	Differential output 1st Channel
7	OUTP1	Output	Differential output 1st Channel
8	G1(1)	Input	Control of the 1st channel
9	G2(0)	Input	Control of the 2nd channel
10	OUTM2	Output	Differential output 2nd Channel
11	OUTP2	Output	Differential output 2nd Channel
12	G2(1)	Input	Control of the 2nd channel
13	G3(0)	Input	Control of the 3rd channel
14	OUTM3	Output	Differential output 3rd Channel
15	OUTP3	Output	Differential output 3rd Channel
16	G3(1)	Input	Control of the 3rd channel
17	GND	Input	Ground pad

Table 1. Pin description.

2.1.2 Gain Control Pins

The gain setting for each channel is given in Table 2.

Gi(1:0)	Description
0 0	Channel OFF (default value set by pull-down devices)
0 1	Channel ON, G = 6 dB
1 0	Channel ON, G = 12 dB
1 1	Channel ON, G = 18 dB

Table 2. Channel gain setting.

Note: For applications that require less than 3 outputs, the unused differential outputs and the corresponding channel gain setting pins can be left floating. The default channel gain setting is “channel OFF [0:0]” (set by internal pull down resistors).

3 ELECTRICAL CHARACTERISTICS

3.1 ABSOLUTE MAXIMUM RATINGS

Stresses above the values listed below may cause permanent device failure. Exposure to absolute maximum ratings for extended periods may affect device reliability.

Symbol	Description	Min.	Max.	Unit
VDDmr	Supply voltage	-0.5	5.5	V
Tmr	Storage temperature	-55	+125	°C
Tjmr	Junction Temperature	-	+125	°C
Pmr	Input level	-	0	dBm

Table 3. Absolute Maximum ratings.

3.2 SPECIFICATIONS

3.2.1 Operating Range

Symbol	Description	Min.	Max.	Unit
VDDop	Supply voltage	4.5	5.3	V
Trop	Temperature	-40	+85	°C

Table 4. Operating Range.

3.2.2 Electrical Specifications

The table below gives the electrical specifications of the LNA under the following conditions:

VDD = 5.0 V, Temperature = 25 °C, Input frequency = 1 GHz, Gain = 18 dB, Pin = -20dBm, unless otherwise specified.

Symbol	Description	Condition	Min	Typ	Max	Unit	
RIN	Input impedance	Single-ended	-	75	-	Ω	
ROUT	Output impedance	Differential	-	100	-	Ω	
FR	Frequency range		0.04	-	2.5	GHz	
G	Gain	S ₂₁ Programmable	-	6	-	dB	
			-	12	-		
			-	18	-		
GFLAT	Gain Flatness	Rs = 75 Ω, maximum gain	-	±1	-	dB	
NF	Noise figure	Rs = 75 Ω	G = 18 dB	-	7	-	dB
			G = 12 dB	-	9	-	
			G = 6 dB	-	13	-	
P1dB	Output P1dB compression point		-	13	-	dBm	
OIP3	Output 3 rd order intermodulation (differential)	f ₁ = 1.0 GHz f ₂ = 1.1 GHz	G = 18 dB	-	22	-	dBm
			G = 12 dB	-	21	-	
			G = 6 dB	-	19	-	
OIP2	Output 2 nd order intermodulation (differential)	f ₁ = 1.0 GHz f ₂ = 1.1 GHz	@ f ₁ + f ₂	-	53	-	dBm
			@ f ₂ - f ₁	-	57	-	
IDD	Current consumption	1 channel enabled	-	130	-	mA	
		2 channels enabled	-	200	-		
		3 channels enabled	-	270	-		
IRL	Input Return loss	-20.log(s ₁₁)	-	15		dB	
ORL	Output Return loss	-20.log(s _{ii})	-	20		dB	
ISOUTIN	RF out to RF in Isolation	-20.log(s _{ii})	50	-	-	dB	
ISOUTOUT	RF out i to RF out j isolation	-20.log(s _{ij})	G = 18 dB	-	25	-	dB
			G = 12 dB	-	30	-	
			G = 6 dB	-	35	-	
ISOUTDWN	RF in to RF out isolation in shut down mode	-20.log(s _{ii})	-	50	-	dB	
CMRR	Common mode rejection at the output		-	20	-	dB	
VESD	ESD robustness on all pins	HBM	3	-	-	kV	

Table 5. Electrical Specifications.

3.3 TYPICAL OPERATING CHARACTERISTICS

The curves below give the typical RF performances of the LNA under the following conditions: VDD = 5.0 V, Temperature = 25 °C, $Z_{Source} = 75\Omega$, $Z_{Load} = 100\Omega$ differential, Frequency range = 40 MHz to 2.5 GHz, input matching network according to application schematics of figure 4.

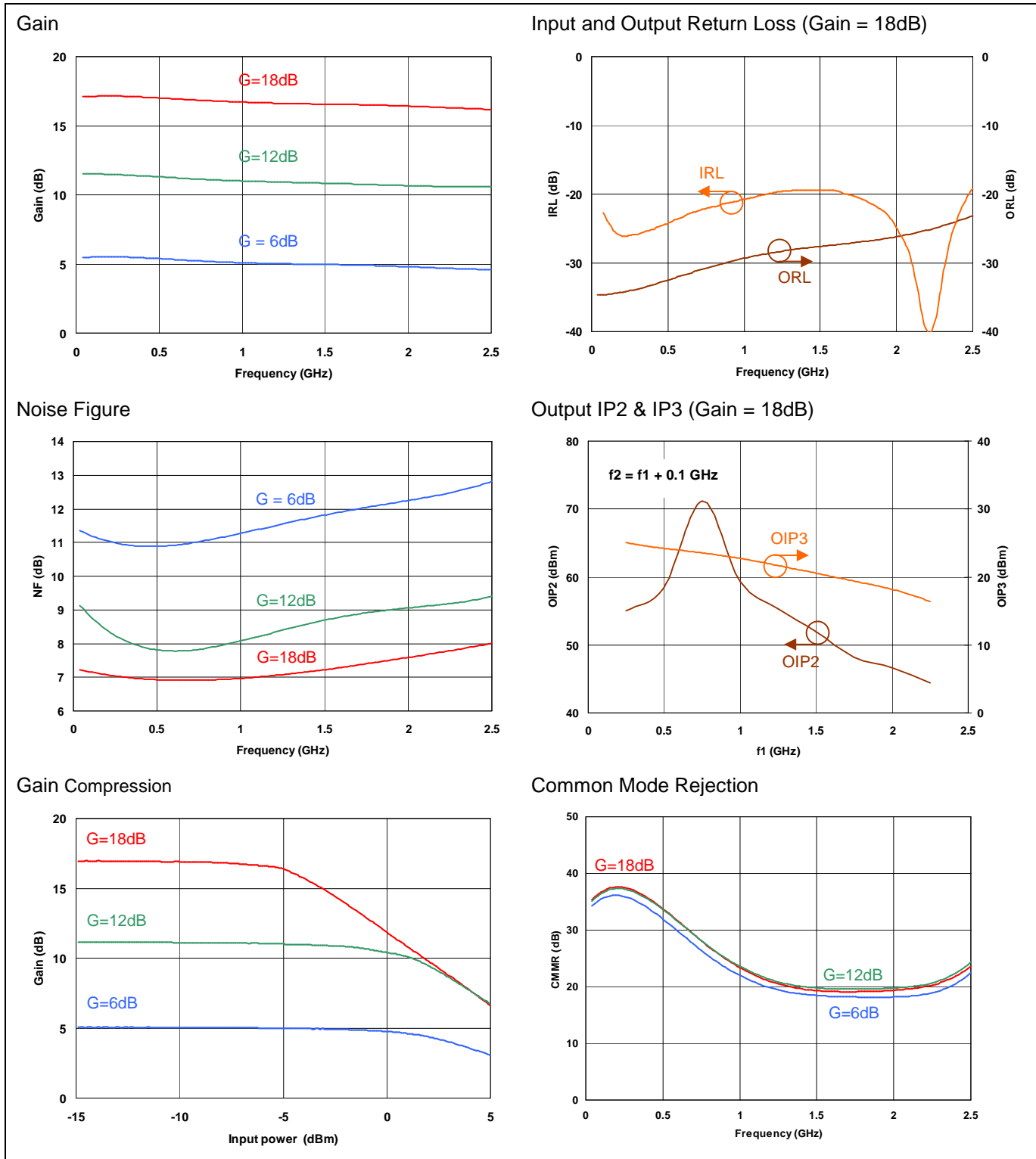

Figure 2. Typical Operating Characteristics Curves.

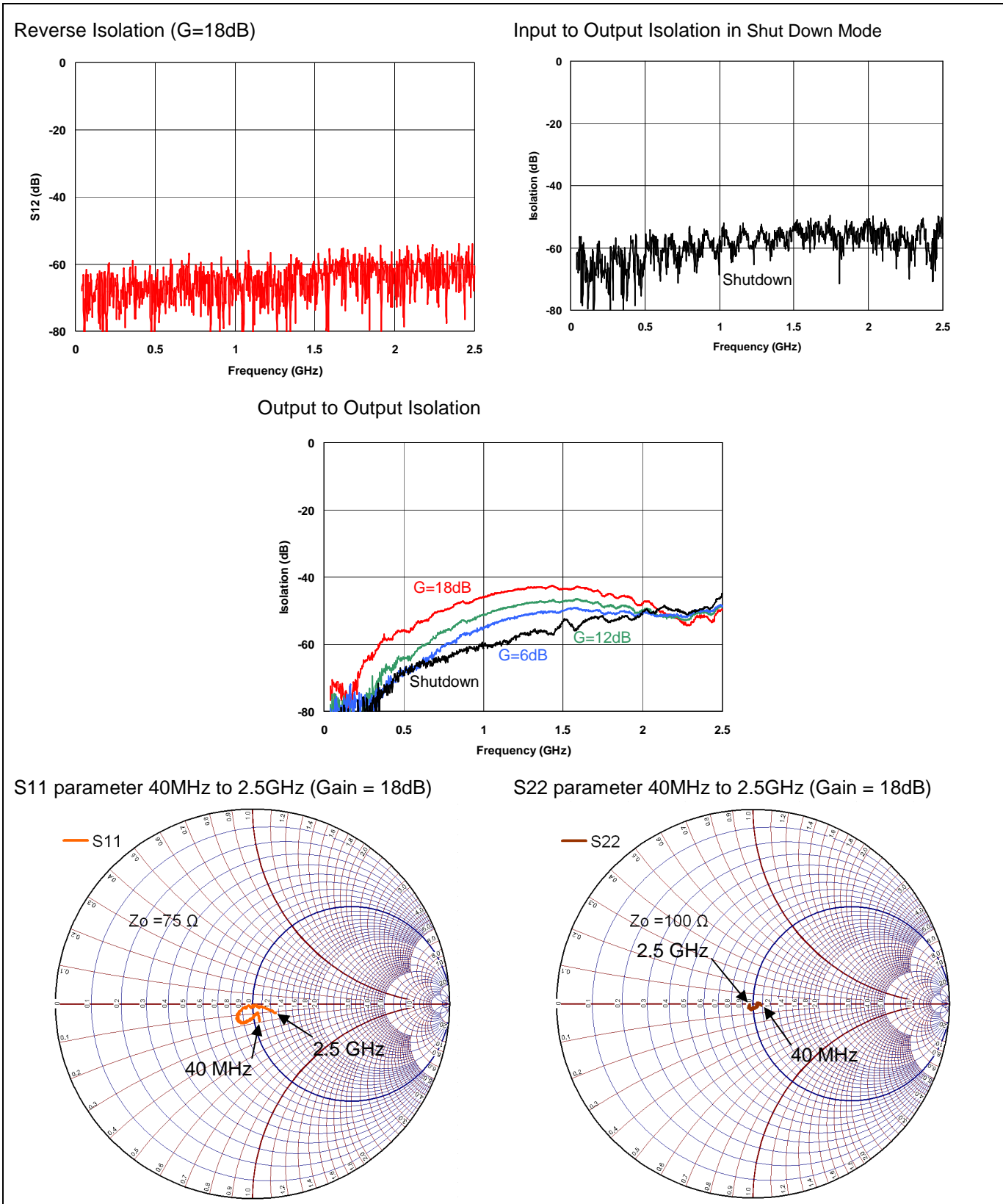

Figure 3. Typical Operating Characteristics Curves.

4 APPLICATION INFORMATION

Figure 4, below, shows the recommended board schematic. Typical component values are shown and are subject to change depending on the PCB layout and material used. Please refer to the Semtech SX1701 reference design at www.semtech.com.

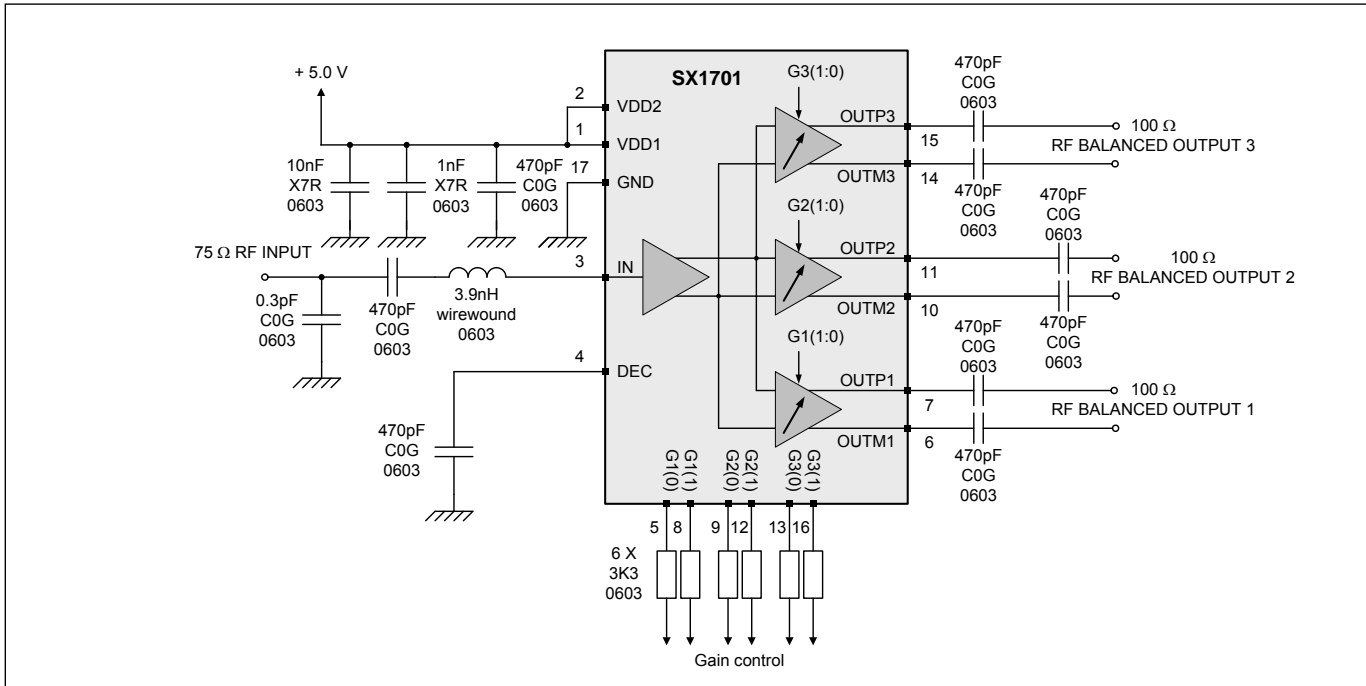

Figure 4. Application board schematic.

5 APPLICATION EXAMPLE

Although intended for differential output operation, the SX1701 may be used for the single-ended output configuration as shown in Figure 5. Note that some degradation in device performance may be experienced, including a 6 dB reduction in gain.

5.1 SINGLE-ENDED INPUT TO DUAL DIFFERENTIAL OUTPUTS WITH LOOP-THROUGH SINGLE-ENDED OUTPUT

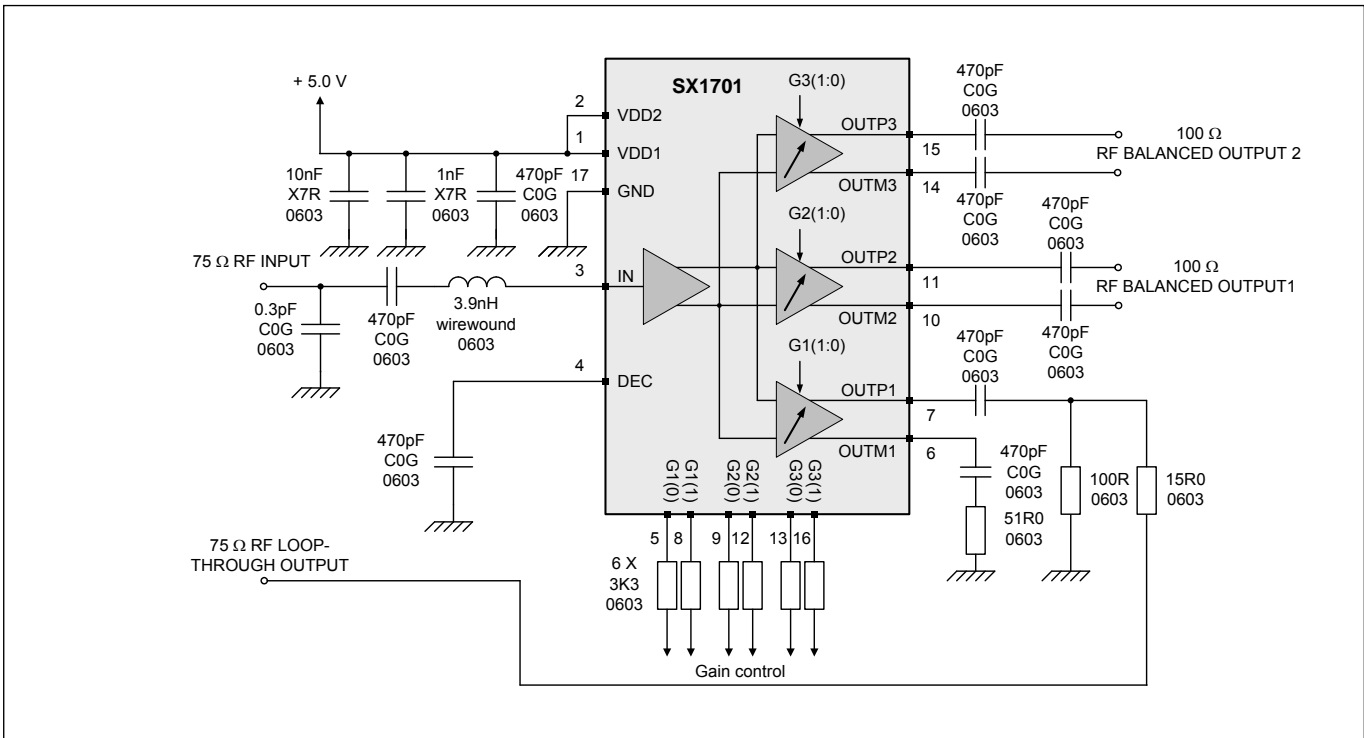

Figure 5. Dual differential outputs with loop-through.

6 PACKAGE OUTLINE DRAWING

SX1701 is assembled in a MLPQ-16, 4 mm x 4 mm as shown in Figure 6.

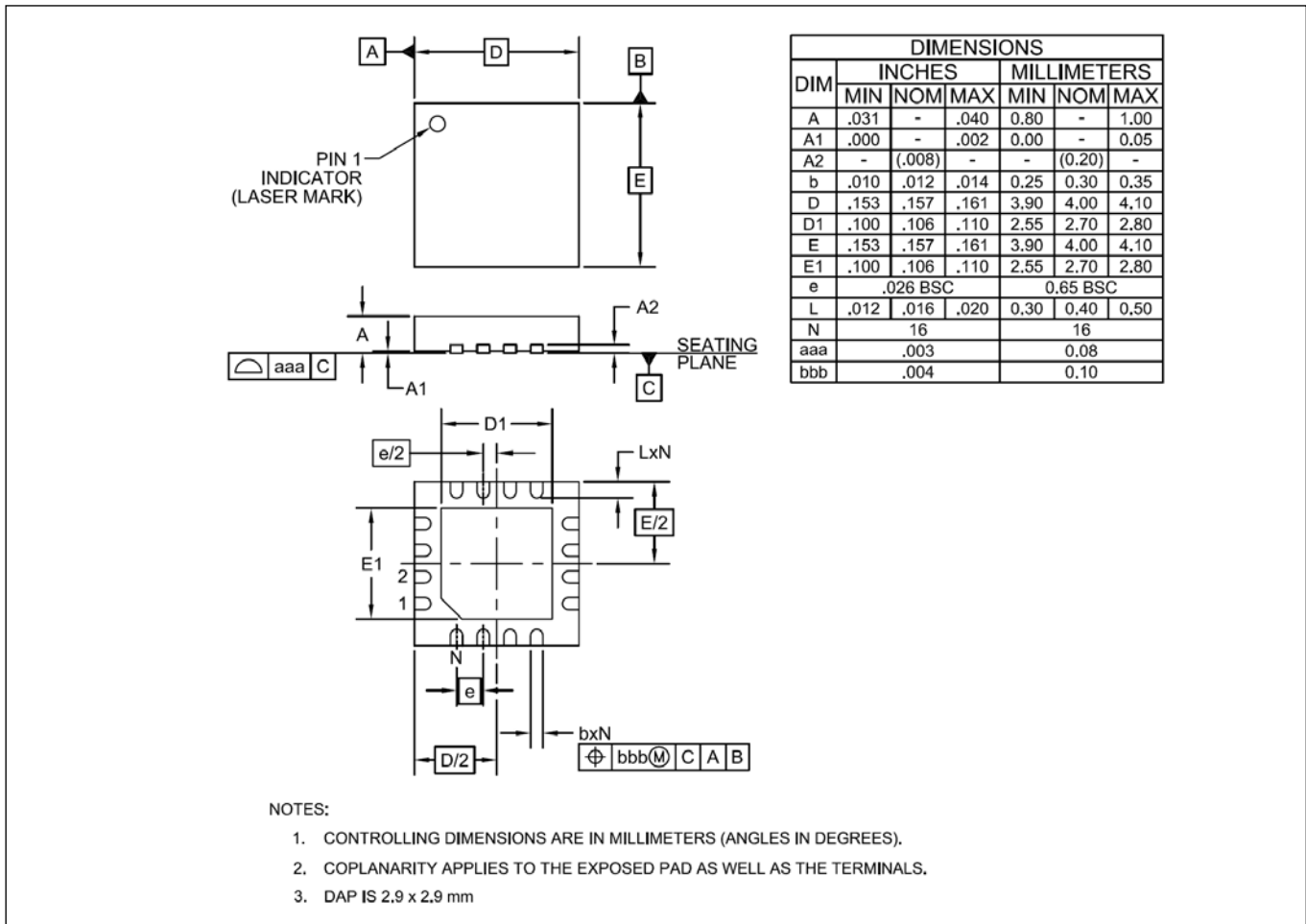

Figure 6. Package outline drawing.

7 MARKING INFORMATION



Figure 7. Marking information.

8 LAND PATTERN DRAWING

The land pattern of MLPQ-16 package, 4 mm x 4 mm is shown in Figure 8.

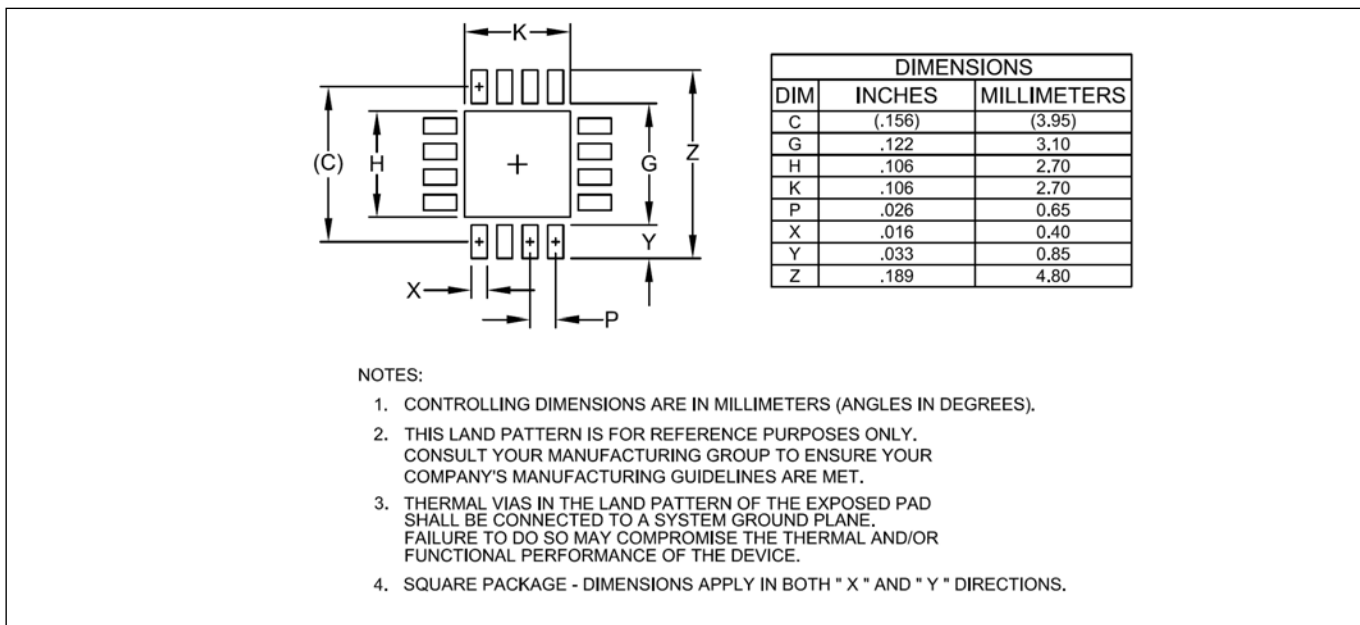

Figure 8. Land pattern drawing.

© Semtech 2008

All rights reserved. Reproduction in whole or in part is prohibited without the prior written consent of the copyright owner. The information presented in this document does not form part of any quotation or contract, is believed to be accurate and reliable and may be changed without notice. No liability will be accepted by the publisher for any consequence of its use. Publication thereof does not convey nor imply any license under patent or other industrial or intellectual property rights. Semtech assumes no responsibility or liability whatsoever for any failure or unexpected operation resulting from misuse, neglect improper installation, repair or improper handling or unusual physical or electrical stress including, but not limited to, exposure to parameters beyond the specified maximum ratings or operation outside the specified range.

SEMTECH PRODUCTS ARE NOT DESIGNED, INTENDED, AUTHORIZED OR WARRANTED TO BE SUITABLE FOR USE IN LIFE-SUPPORT APPLICATIONS, DEVICES OR SYSTEMS OR OTHER CRITICAL APPLICATIONS. INCLUSION OF SEMTECH PRODUCTS IN SUCH APPLICATIONS IS UNDERSTOOD TO BE UNDERTAKEN SOLELY AT THE CUSTOMER'S OWN RISK. Should a customer purchase or use Semtech products for any such unauthorized application, the customer shall indemnify and hold Semtech and its officers, employees, subsidiaries, affiliates, and distributors harmless against all claims, costs damages and attorney fees which could arise.

Contact Information

Taiwan	Tel: 886-2-2748-3380 Fax: 886-2-2748-3390	Switzerland	Tel: 41-32-729-4000 Fax: 41-32-729-4001
Korea	Tel: 82-2-527-4377 Fax: 82-2-527-4376	United Kingdom	Tel: 44-1794-527-600 Fax: 44-1794-527-601
Shanghai	Tel: 86-21-6391-0830 Fax: 86-21-6391-0831	France	Tel: 33-(0)169-28-22-00 Fax: 33-(0)169-28-12-98
Japan	Tel: 81-3-6408-0950 Fax: 81-3-6408-0951	Germany	Tel: 49-(0)8161-140-123 Fax: 49-(0)8161-140-124