

PROTECTION PRODUCTS

Surge Protection of ISDN U-Interfaces

ISDN equipment is exposed to harsh transient conditions resulting from such sources lightning, ESD, and ac power disturbances. This application note describes how to implement transient surge protection for ISDN U-Interfaces.

U-Interface Protection Topology

The ISDN U-Interface is a two wire connection which usually connects the customer premises to the central office. Since the U-Interface connects to the central office, it is subject to the same harsh transient environment as analog switching systems. Careful consideration of circuit topology and suppression device characteristics are necessary to ensure a reliable system design. A typical U-Interface protection circuit is shown in Figure 1. The design is intended to meet the outside line requirements of Bellcore 1089 and FCC Part 68. The circuit topology takes advantage of two types of suppression technologies to exploit the positive attributes of each. On the line side of the interface, the central office battery voltage (typically -48 volts in the U.S.) is present on the RING line. Therefore, a device with a high stand-off voltage and

high surge current capability is needed. Line side protection is obtained using 58V TVS thyristors with high surge current capability.

For transients which are coupled through the transformer, a low capacitance TVS diode is used. Since only the digital component of the signal is present on the line side protection is accomplished using the LC03-6. The low capacitance rating of the device (typically <16pF) preserves the transmitted signal integrity, while the low operating voltage provides maximum protection by minimizing the stress on the transceiver's internal structure under surge conditions. Other key device characteristics include fast response time for suppression of extremely fast transients like ESD, and high surge capability for suppression of lightning induced surges.

For AC power cross protection requirements, positive temperature coefficient (PTC) resistors are utilized. Under fault conditions, the PTC heats up causing the resistance of the device to increase dramatically. After the fault passes, the devices automatically resets.

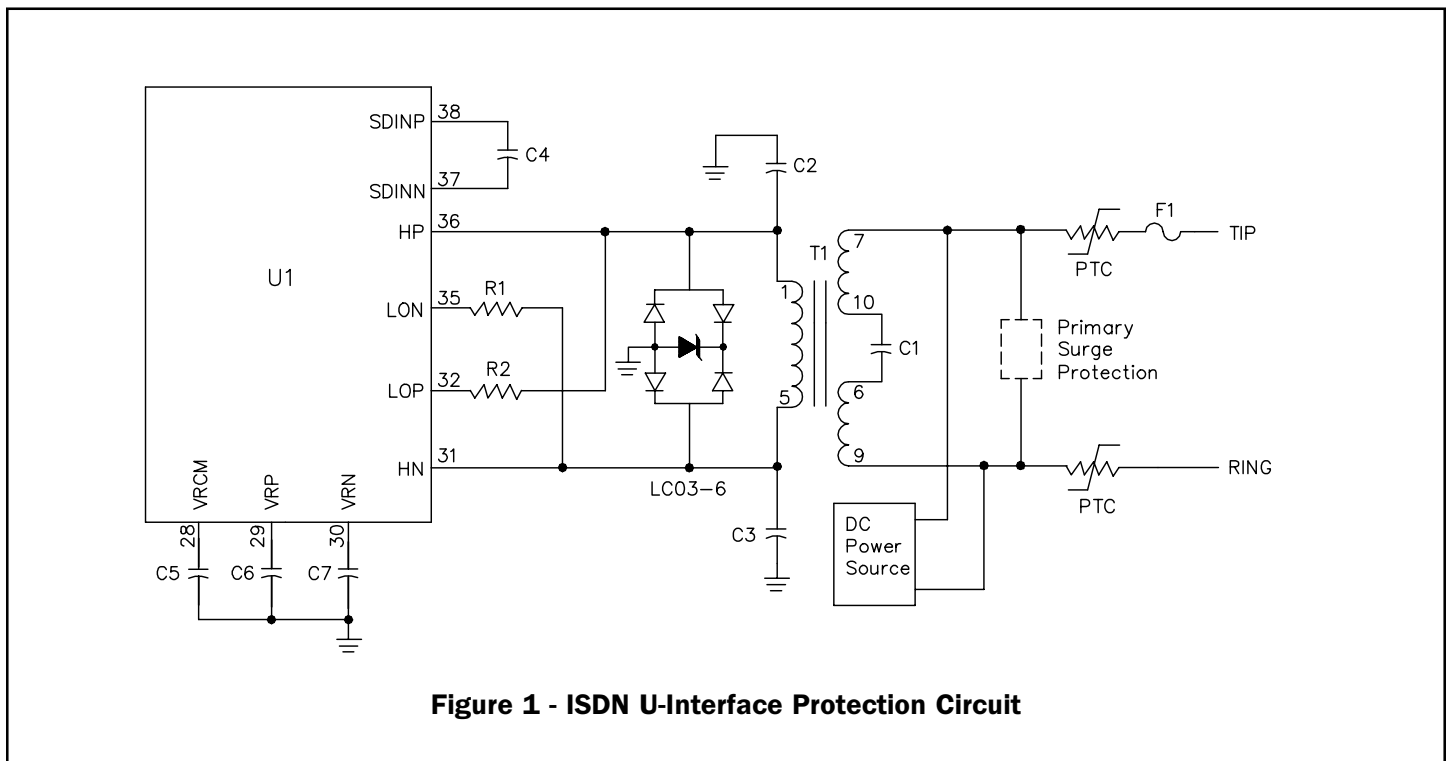

Figure 1 - ISDN U-Interface Protection Circuit