

PROTECTION PRODUCTS

Low Capacitance Devices

The junction capacitance of a TVS diode is naturally large. In high speed data transmission applications, the extra capacitance introduced by protection devices needs to be kept to a minimum.

Low capacitance devices are (Figure 1) are manufactured by placing a low capacitance rectifier diode (D_1) in series but opposite in polarity with the TVS diode (D_2). This has the effect of adding another capacitor (C_1) in series with the junction capacitor of the TVS diode (C_2). Taking advantage of the relationship for series capacitors [$C_T = C_1 * C_2 / (C_1 + C_2)$] means the resulting capacitance will be less than the smallest component in series. By carefully choosing the rectifier, the effective capacitance may be reduced by approximately two orders of magnitude.

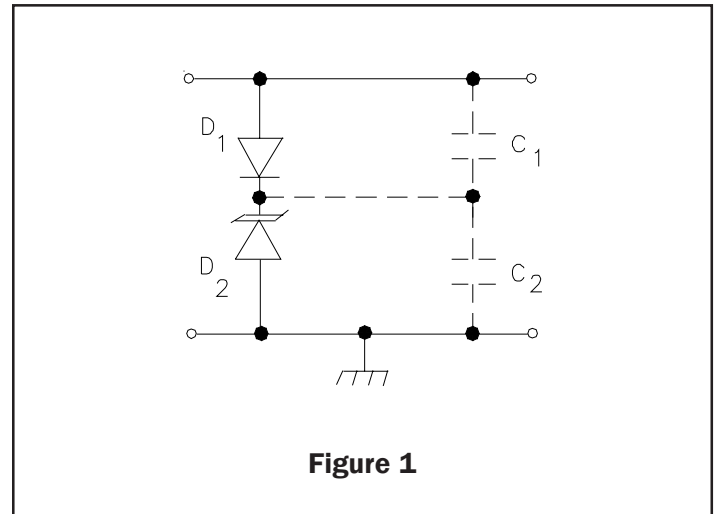

Figure 1

Using Low Capacitance Parts

For bidirectional applications, a TVS/rectifier pair is connected in an anti-parallel configuration across the line (Figure 2). In this configuration, D_1 & D_2 will conduct positive surges while D_3 & D_4 will conduct negative surges. In unidirectional applications, designers need to take into consideration the following:

In Figure 3a, if a positive surge occurs on the line, D_1 will conduct in the forward direction and the TVS D_2 will avalanche and i_1 will flow through the device. If a negative spike occurs however, surge current i_2 flows, forward biasing D_2 while D_1 is subject to the full surge in the reverse bias direction. The power handling capability of D_1 will be exceeded resulting in heating and destruction of the device. Adding an additional diode D_3 in parallel (Figure 3b), ensures D_1 will not be reversed biased under transient conditions. D_3 will conduct i_2 under this condition, thus preventing failure. Semtech has introduced devices for unidirectional applications which incorporate D_3 as an integrated part.

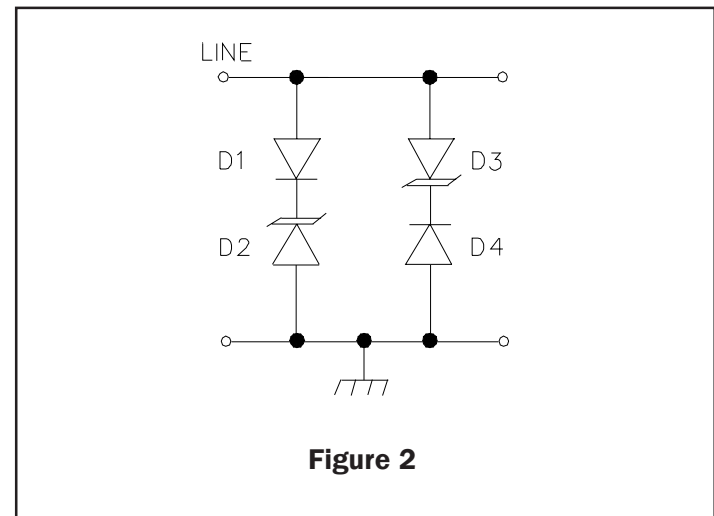

Figure 2

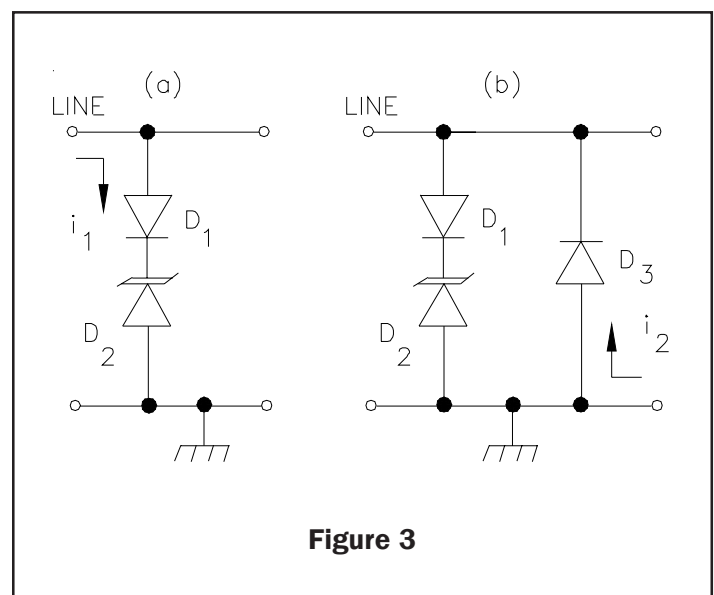

Figure 3