

POWER MANAGEMENT**Description**

Three components make a complete system: any microcontroller, the SH3003, and a bypass capacitor. This low-cost system would consume very little power and have clock-frequency accuracy of $\pm 0.5\%$. A fourth component, a 32.768kHz crystal, raises the clock frequency accuracy to $\pm 0.0256\%$ (± 256 ppm).

The SH3003 can operate completely stand-alone, or under control of the microcontroller. A single-wire interface handles both bi-directional communications and the interrupt/wake-up signal from the SH3003. The SH3003 stores all configuration, calibration, parameters, and status information in a 36-byte bank of control registers. On reset, most of these are reloaded with defaults from the factory-set non-volatile memory. The microcontroller can change any settings on the fly. If some of the settings must remain fixed, a comprehensive set of write-protect bits is provided for several related groups of registers (with both permanent write-inhibit and lock/unlock capabilities).

A backup power source may also be connected to the SH3003. The IC can directly accommodate 2/3-cell zinc-carbon/alkaline, 2/3-cell mercury, 2/3/4-cell NiCd/NiMH, one cell Li/Li+ batteries, or a super cap.

The programmable SH3003 MicroBuddy® (μ Buddy®) provides all mandatory microcontroller support functions:

- ◆ CPU Supervisor
- ◆ Clock Management System
- ◆ Real-Time Support
- ◆ Auxiliary Functions

Applications

- ◆ Home automation and security
- ◆ Consumer products
- ◆ Portable/handheld computers
- ◆ Industrial equipment
- ◆ Any microcontroller-based product

Features

- ◆ Highly integrated
 - IC - 3mm x 3mm x 0.9mm, 16-lead MLP (QFN) package
- ◆ CPU Supervisor
 - Low VDD reset programmable from 2.3V to 4.3V
 - Watchdog timer with programmable time out periods
 - Both active-high and active-low reset outputs
- ◆ Clock Management System
 - Replaces high-frequency (HF) crystal or resonator
 - Programmable clock output from 32.768kHz to 16MHz
 - Speed shift between multiple clock frequencies
 - Adjustable spectrum spreading for EMI reduction
 - Directly supports microcontroller STOP function
 - Deep sleep with instantaneous auto-wakeup
- ◆ Real-Time Support
 - 179 year real-time clock, battery-backup capable
 - Dedicated 32.768kHz buffered clock output
 - Built-in trim for 32.768kHz oscillator to ± 4 ppm
 - Programmable periodic interrupt/wakeup timer
- ◆ Auxiliary Functions
 - 4-byte (32-bit) scratchpad RAM, loaded on reset with factory-set value (zero or optional ID code)
 - All settings programmable in real time, defaults restored from nonvolatile memory on reset
- ◆ Operates from 2.3V to 5.5V
 - $I_{DD} < 850\mu A / 2MHz$, $< 3mA / 16MHz$, $< 10\mu A /$ standby - $I_{BUP} < 2\mu A / I_{BSB} < 50nA$ (battery back up/standby)

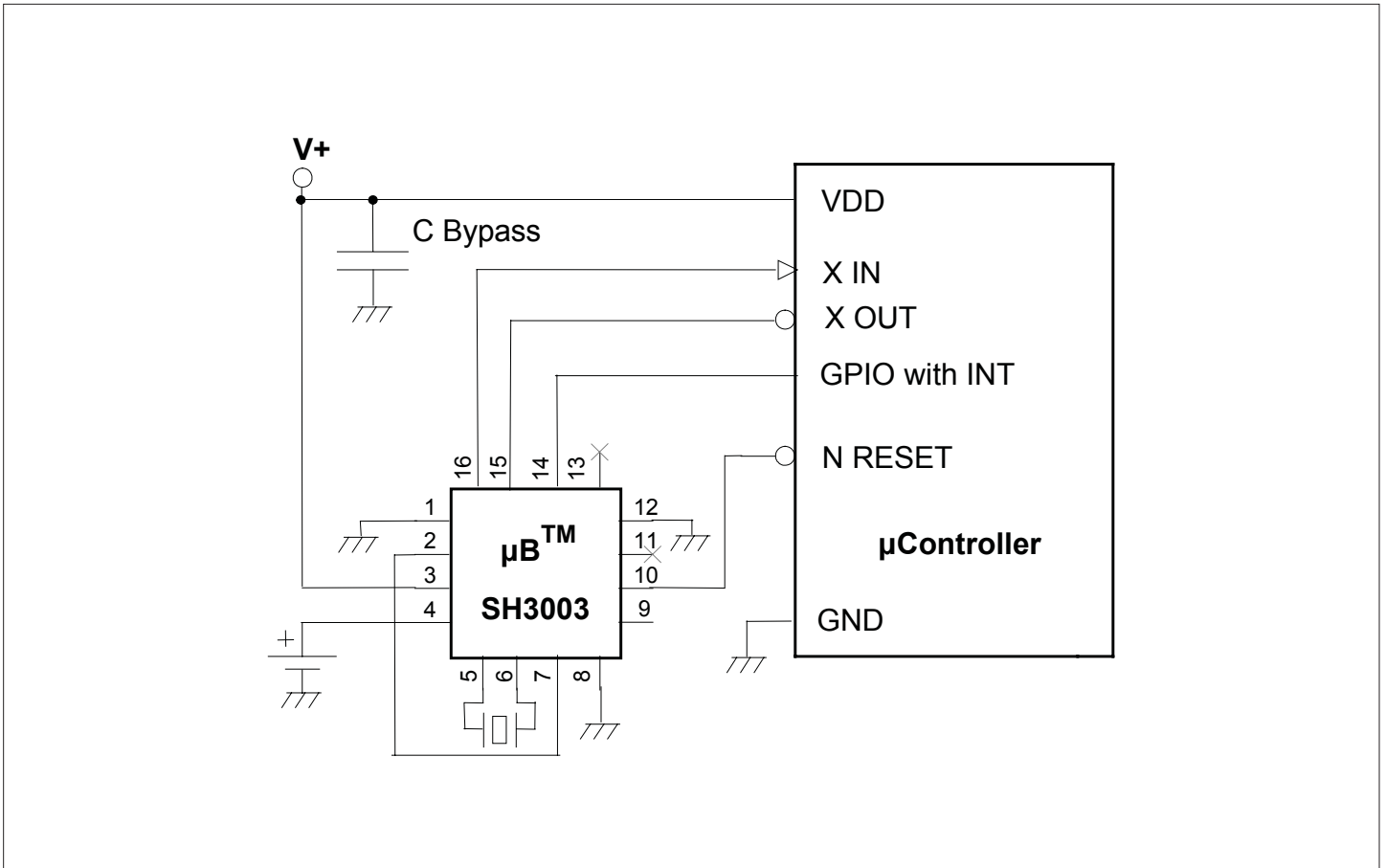

Typical Application Circuit with High Clock Accuracy

POWER MANAGEMENT
Absolute Maximum Ratings

Exceeding the specifications below may result in permanent damage to the device or device malfunction. Operation outside of the parameters specified in the Electrical Characteristics section is not recommended.

Parameter	Symbol	Min	Max	Units
Supply voltages on VDD or VBAK relative to ground	V_{DD}	-0.5	5.5	V
Input voltage on CLKIN, IO/INT, TEST	V_{IN1}	-0.5	VDD + 0.5	V
Input voltage on CLKSEL	V_{IN2}	-0.5	VREG + 0.5	V
Input current on any pin except VREG	I_{IN1}		10	mA
Input current on VREG	I_{IN2}		150	mA
Ambient operating temperature	T_{OP}	-40	85	°C
Storage Temperature	T_{STG}	-55	60	°C
IR Reflow temperature - SH3003IMLTR	T_{IRRT}		240	°C
IR Reflow temperature - SH3003IMLTRT	T_{IRRT}		260	°C

Electrical Characteristics

Parameter	Symbol	Min	Typ	Max	Units	Notes
Case temperature	T_{OP}	-40		+85	°C	
Supply voltage	V_{DD}	2.3		5.5	V	
Supply current, CLKOUT = 16 MHz ⁽¹⁾	I_{DD}			3	mA	
Supply current, CLKOUT = 8 MHz ⁽¹⁾	I_{DD}		1.8		mA	
Supply current, CLKOUT = 2 MHz ⁽¹⁾	I_{DD}		0.9		mA	
Standby current, 32.768kHz crystal ⁽²⁾	I_{SB}			8	µA	CLK32 disabled
Standby current, 32.768kHz RC oscillator ⁽²⁾	I_{SB}			10	µA	CLK32 disabled
Backup supply voltage ⁽²⁾	V_{BAK}	2.3		5.5	V	
Backup current, 32.768kHz crystal ⁽²⁾	I_{BUP}			2	µA	CLK32 disabled
Backup current, 32.768kHz RC oscillator ⁽²⁾	I_{BUP}			8	µA	CLK32 disabled
Backup standby current ⁽²⁾	I_{BSB}			50	nA	VDD > VBO

Notes:

- 1) Assuming load on CLKOUT < 20pf
- 2) Assuming temperature < 60°C

POWER MANAGEMENT
Electrical Characteristics (continued)
Crystal Oscillator

Parameter	Symbol	Min	Typ	Max	Units
Crystal operating frequency	F_{OP}		32.768		kHz
CLK32 duty cycle	DC	25		75	%
Start-up time	T_{ST}			3	secs
XIN/XOUT padding capacitance after power-up	C_{PUP}		12.5		pF
Minimum X_{IN}/X_{OUT} padding capacitance	C_{MIN}		10		pF
Maximum X_{IN}/X_{OUT} padding capacitance	C_{MAX}		40		pF
Padding capacitance resolution	C_{RES}		2		pF
X_{IN} switching threshold	V_{TH}		0.6		V
X_{IN} to CLK32 delay	T_D		0.5		ppm/°C
CLK32 frequency stability (crystal-dependent)	F_S		1		μs
CLK32 cycle-to-cycle jitter	J		0.05		%
CLK32 rise/fall time (10pF load)	T_{RF}		10		ns
CLK32 logic output low (0.5mA load)	V_{OL}		0.25	0.5	V
CLK32 logic output high (0.5mA load)	V_{OH}	-0.5	-0.25		Ref VDD*

*Note: VDD here is VDD during normal operation and VBAK during battery backup.

32.768kHz RC Oscillator

Parameter	Symbol	Min	Typ	Max	Units
External 1MΩ referenced nominal frequency	F_{EXT}		32.768		kHz
Internal 1MΩ referenced nominal frequency	F_{INT}		32.768		kHz
CLK32 duty cycle*	DC	40		60	%
Programmed frequency accuracy at 25°C	F_{ST}	-1		+1	%
Absolute accuracy (temp. & supply external 1MΩ)	F_{DE}		±2		%
Absolute accuracy (temp. & supply internal 1MΩ)	F_{DI}		±3		%
Frequency temperature stability (ext. 1MΩ)	F_{SE}		100		ppm/°C
Frequency temperature stability (int. 1MΩ)	F_{SI}		200		ppm/°C
Power on start-up time	T_{ST}		70		μs
CLK32 cycle-to-cycle jitter*	J		0.1		%

*Note: After power-up, pin CLK32 is disabled, pin RREF is also disabled, and the oscillator is set to operate without the external reference resistor.

POWER MANAGEMENT
Electrical Characteristics (continued)
Programmable Reset

Parameter	Symbol	Min	Typ	Max	Units
VDD switching threshold after power-up	$V_{BO(PUP)}$		2.3		V
VDD switching threshold for min code $V_{BO(MIN)}$	$V_{BO(MIN)}$	2.27	2.3	2.33	V
VDD switching threshold for max code	$V_{BO(MAX)}$	4.2	4.3	4.4	V
VDD threshold resolution	V_{RES}		33		mV
VDD hysteresis	V_{HYS}		50		mV
Falling VDD threshold switch delay	Td		2.5		μ s
Threshold DAC settling time	TDAC		4		ms
Minimum VDD for valid NRST and RST	$V_{DD(MIN)}$			1	V

High-Frequency Oscillator (HFO)

Parameter	Symbol	Min	Typ	Max	Units
Minimum operating freq. (start-up default = 16MHz)	F_{MIN}		5.6	8	MHz
Maximum operating frequency	F_{MAX}	16.8	21		MHz
Frequency resolution	F_{RES}	-0.3	2		kHz
Programmed frequency accuracy at 25°C	F_{ST}			+0.3	%
Frequency drift over temperature and supply	F_{DRIFT}		\pm 0.5		%
CLKOUT cycle-to-cycle jitter (spread spectrum off)	J		0.1		%
Start-up time from standby	T_{START}			2	μ s
Settling time to 0.1% after HF digitally-controlled oscillator (DCO) code change	T_{SETT}		10		μ s
CLKOUT duty cycle	DC	40		60	%
Frequency temperature stability	F_{TS}		100		ppm/°C
Short-term frequency stability	F_S		0.5		%/sec
Minimum spread spectrum range*	$SS_{(MIN)}$		32		kHz
Maximum spread spectrum range*	$SS_{(MAX)}$		256		kHz
CLKOUT rise/fall time (20pF load)	T_{RF}		3		ns
CLKOUT logic output low (4mA load)	V_{OL}		0.25	0.4	V
CLKOUT logic output high (4mA load)	V_{OH}	-0.4	-0.25		Ref VDD

*Note: After power-up, spectrum spreading of the high-frequency oscillator is disabled.

POWER MANAGEMENT

Pin Configuration

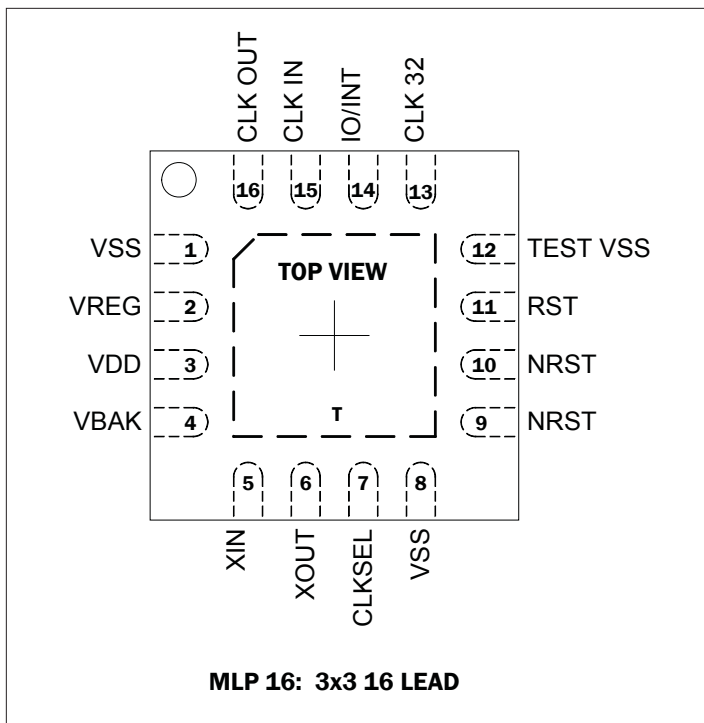

Ordering Information

Device	Package
SH3003IMLTR	MLP 3x3mm, 16 pins
SH3003IMLTRT	MLP 3x3mm, 16 pins, lead-free
EVK-SH3000USB	SH3000 Evaluation Kit
SH3000EK.pdf	SH3000 Evaluation Kit User Guide
SH3000UM.pdf	SH3000 Reference Manual

Pin Descriptions

Pin	Pin Name	Type	Pin Function
T			Thermal pad - connect to ground
1	VSS	Power	Ground, 0V - All Vss pins and TEST (Vss) pin must be connected together.
2	VREG	Power	Output of internal Voltage Regulator, 2.2V nominal. This pin can power external loads of < 5mA. If load is "noisy" it requires a bypass capacitor. May be left unconnected or used as a high logic level signal for CLKSEL pin.
3	VDD	Power	Main power supply, +2.3 to +5.5V
4	VBAK	Power	Back-up power supply for real-time clock, +2.3 to +5.5V (+1.8 to +5.5V typical). This voltage can be higher or lower than VDD. Connect a backup battery or backup capacitor (with external recharge circuit). Connect to VDD if not used.
5	XIN	Analog In	Oscillator pins for optional external low frequency crystal, typically 32.768kHz crystal with nominal 12.5pF load cap. Keep open or connect to Vss if not used.
6	XOUT	Analog Out	
7	CLKSEL	Digital In	A logic low level selects the internal 32.768kHz RC oscillator (CLKSEL tied to Vss). A high state on this pin selects the 32.768kHz crystal oscillator (CLKSEL is connected to VREG). The SH3003 always starts up using the internal 32.768kHz RC oscillator. If CLKSEL is high, the internal 32.768kHz clock switches to the crystal oscillator once it has stabilized, and RC oscillator is disabled for power conservation. Do not connect CLKSEL to any signals except Vss or VREG. CLKSEL must not be left open.
8	VSS	Power	Ground, 0V. All Vss pins and TEST (Vss) pin must be connected together.

POWER MANAGEMENT
Pin Descriptions (continued)

Pin	Pin Name	Type	Pin Function
9	RREF	Analog	Optional 1M Ω external bias resistor for internal 32.768 kHz RC oscillator. Can be used to set, trim or modulate the internal RC oscillator. Keep open if not used.
10	NRST	Digital Out	Active low system reset output. Asserted with a strong low state when a reset condition occurs. Weakly pulled to V _{DD} internally when not active. This signal is valid for V _{DD} as low as 1V. Keep open if not used.
11	RST	Digital Out	Active high system reset output. Asserted with a strong high state when a reset condition occurs. Weakly pulled to V _{SS} internally when not active. This signal is valid for V _{DD} as low as 1 V. Keep open if not used.
12	TEST (V _{SS})	Digital In	Factory test enable. All V _{SS} pins & TEST (V _{SS}) pin must be connected together.
13	CLK32	Digital Out	Buffered internal 32.768 kHz clock, derived according to the CLK _{SEL} pin setting. Pin uses backup power for the buffer when V _{DD} is not present. When driving high, this signal is either at V _{BAK} or V _{DD} (if V _{DD} is higher than the reset threshold). When enabled, this signal runs continuously independent of CLK _{OUT} activity. Minimize the external load to reduce power consumption during backup operations. When disabled, this pin is driven to V _{SS} . Keep open if not used.
14	IO/INT	I/O	Serial communications interface and interrupt output pin. Pin is internally weakly pulled to opposite of programmed interrupt polarity. If interrupt is programmed to be active low, pin is weakly pulled to V _{DD} when inactive. Keep open if not used.
15	CLK _{IN}	Digital In	Clock activity sense input. Detects when target microcontroller enters stop mode (which disables its clock). Connect to the microcontroller's clock output or oscillator output pin. Connect to V _{SS} when not used. CLK _{IN} must not be left open.
16	CLK _{OUT}	Digital Out	Programmable high frequency clock output. Connect to the target microcontroller's clock input or oscillator input pin. Keep open if not used.
T	Thermal Pad		Pad for heatsinking purposes. Connect to ground plane using multiple vias. Not connected internally.

POWER MANAGEMENT

Block Diagram

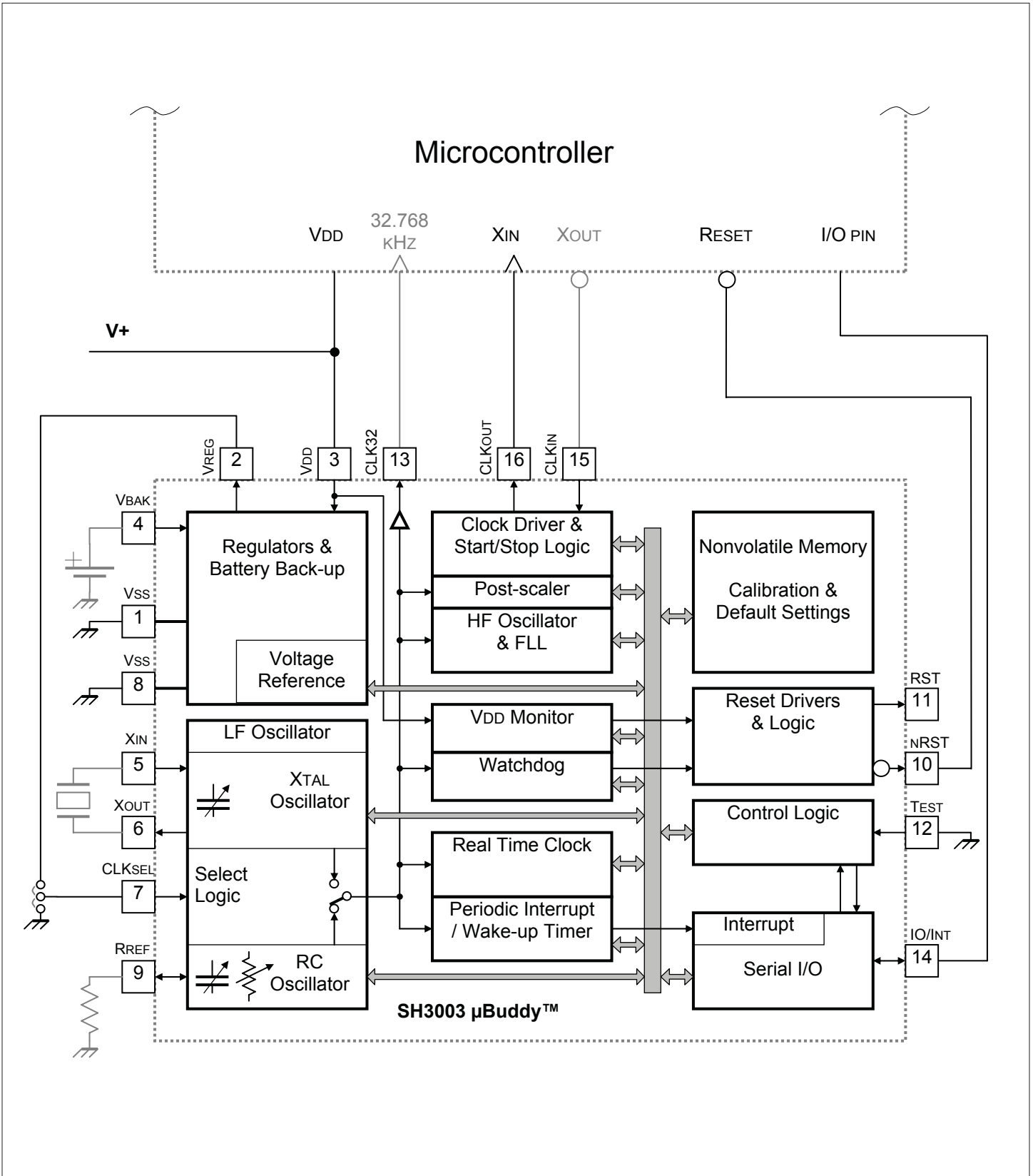

POWER MANAGEMENT

Application Information

The SH3003 is a single-chip support system for microcontrollers, microprocessors, DSPs and ASICs. It consists of four major functional blocks, each block having numerous enhancements over alternative solutions.

The major modules are the CPU Supervisor, the Clock Management System, the Real-Time Support, and the Auxiliary functions.

The entire chip is controlled by the set of internal registers and accessed via the single-pin serial interface. All of the settings, configuration, and calibration or operating parameters are programmable and re-programmable at any time. All of the parameters required for stand-alone operations are initialized on reset from the built-in factory-programmed nonvolatile memory. This allows the SH3003 to operate autonomously for most of its supervisory functions. The stand-alone operations do not require the use of the serial interface or any of the initialization and control operation, but without these, the full potential benefit of the SH3003 may not be realized. In the preferred configuration, where the SH3003 is tightly coupled to the target micro, the SH3003 offers an unprecedented level of design flexibility in clock and power usage management.

The SH3003 is a particularly desirable integration because the built-in features interact and meld to produce more useful system level functions.

For example, on power-up, the SH3003 can quickly release the reset lines on its CPU Supervisor module because the clock signal from the Clock Management System is guaranteed to be running and stabilized. An ordinary reset circuit must hold reset active for a long time to allow an unknown crystal to start up and stabilize.

The SH3003 offers several ways to minimize system power consumption, such as allowing the target processor to enter deep sleep by stopping its clock completely, and to wake up as often as necessary with no external support. The clock can be programmed to start up at a given frequency, and software can adjust it dynamically to manage power consumption and different operating modes.

Users should consider the interactions of the major functional blocks to gain the maximum advantage from the SH3003. The individual functional blocks are described in the following sections.

Default Start-Up Parameters

While the operating parameters of the SH3003 are programmable by the host microcontroller at any time, the default start-up parameters and appropriate calibration values are programmed into the chip's nonvolatile memory at the factory. This enables the SH3003 to be used stand-alone or in an embedded application with minimal microprocessor intervention.

Default start-up parameters for the SH3003 are:

- Reset and V_{BO} voltage level is 2.3V
- CLK_{OUT} frequency is 16.0MHz
- CLK32 output is disabled
- Spread spectrum is disabled
- Internal RC oscillator is calibrated (to nominal frequency of 32768Hz)

Internal load capacitors on the 32.768kHz crystal oscillator pins are set to 12.5pF.

POWER MANAGEMENT

Application Information (continued)

CPU Supervisor

The SH3003 has two supervisory functions that manage the reset of the target processor, a low V_{DD} monitor (Brownout Detector) and a Watchdog Timer, see Figure 1.

Both functions are integrated with the Clock Management System to provide a more complete system solution than stand-alone components.

The SH3003 has both active high and active low reset output pins. Both are driven strong to the active state and weak to the inactive state. This eliminates the need for external pull-ups and allows various reset sources to be connected together in a wire-OR configuration. (This makes it simple to set up a manual reset circuit.)

A set of flags in the register map indicates the source of the reset to the system software.

Low V_{DD} Reset

The SH3003 drives the reset pins active whenever V_{DD} is below the value of V_{BO}, the brownout reset threshold, programmable from 2.3V to 4.3V in average steps of 33mV, see Table 1.

Parameter	Min	Typ	Max	Units
V _{BO} for min code (000000)	2.27	2.3	2.33	V
V _{BO} for max code (111111)	4.2	4.3	4.4	V
Step resolution		33		mV

Table 1

The default V_{BO} value is loaded on power-up from the factory-programmed non-volatile memory. It can be re-programmed at any time or it can be permanently protected from any changes by setting the V_{BO} Lock flag or a write-protect flag.

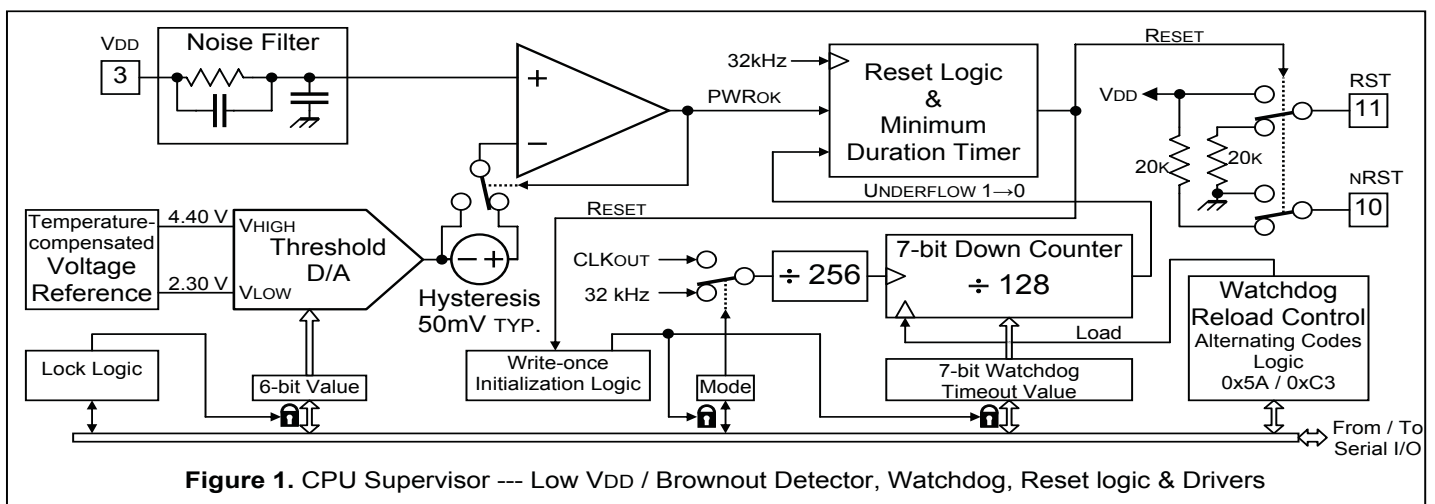

POWER MANAGEMENT

Application Information (continued)

Low VDD Reset (continued)

On power up both the active-high and active-low reset signals are driven active. These outputs are typically valid for a VDD level of at least 0.5V, and guaranteed to be valid for a VDD level of 1.0V.

The reset outputs remain active until VDD rises and stays above the level of (VBO + VHYST), where VHYST is a small fixed amount of hysteresis, nominally 50mV, added to prevent nuisance reset activations (when VDD slowly changes near the level of VBO and some noise or power glitching is present).

At the level of (VBO + VHYST) the power supply is considered valid. In case of the initial power-up, the reset is then driven inactive once 6ms of valid power have elapsed. In the case of brownout, the reset is released after a delay of 6ms (but no less than 12ms from the beginning of the brownout). Such a fast reset is possible because the SH3003 provides a fast-starting clock that is free of crystal start-up time requirements. This gives the SH3003 an advantage over most external reset circuits, which must have a long reset pulse duration to accommodate long and unpredictable crystal start-up times.

The SH3003 guarantees that a valid and stable clock is available 2ms before the reset signals are negated, so that internal synchronous reset and initialization of the target micro can proceed normally.

Since the clock is only active for the last 1 or 2ms of the reset interval, when VDD has already been valid for some time, energy savings are realized and the start-up of the whole system is made easier. The commonly used reset approach forces the processor to turn the oscillator on and to run at full speed (thus consuming full power) during the critical time when the (possibly depleted) battery is trying to raise VDD to an acceptable level. In contrast, the SH3003 allows the power source to charge the bypass capacitors and raise the level of VDD with little additional load. Only when power has stabilized is the target micro permitted to start expending energy.

When a brownout event occurs, the SH3003 continues to provide the clock to the target processor, but at a reduced frequency between 500kHz and 1.0MHz. After a delay of 2ms this clock is stopped, automatically lowering the energy consumption of the whole system, (see Figure 2).

A Noise Filter (see Figure 1, Page 10) prevents reset activations from noise and small power glitches on the VDD line. A typical behavior is shown in Figure 3 for the VDD level just above VBO and various amplitudes and durations of the negative-going spikes.

When VDD is falling, both reset lines are guaranteed to activate within 5µs from the time VBO is crossed over.

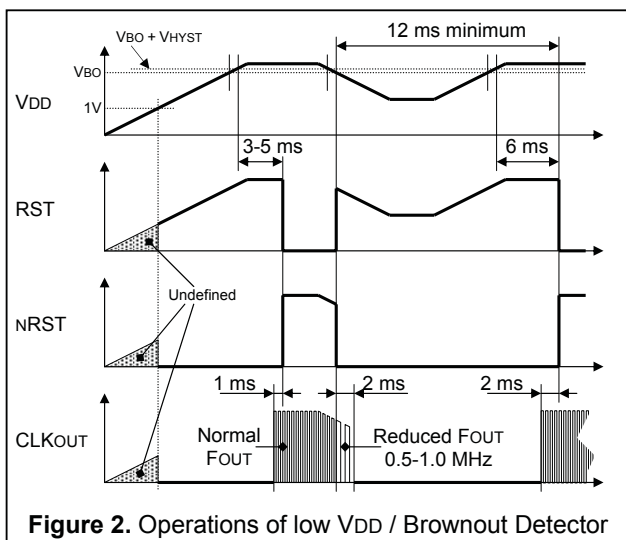

Figure 2. Operations of low VDD / Brownout Detector

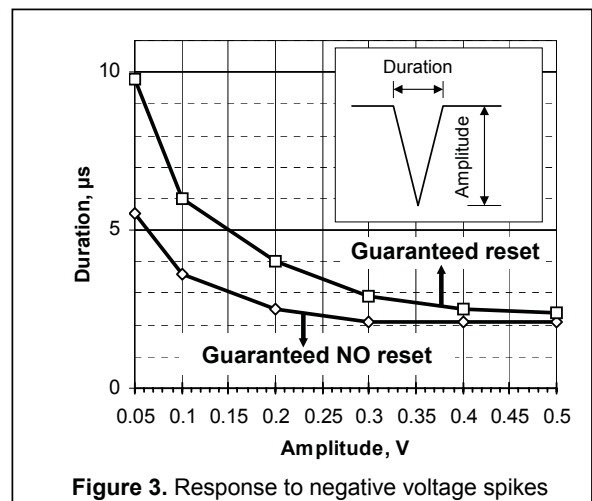

Figure 3. Response to negative voltage spikes

Watchdog Timer

The second circuit for supervising the processor is the watchdog timer. Whereas the low V_{DD} /Brownout Detector monitors supply voltage, the watchdog timer monitors behavior. It is based on a programmable timer that must be restarted periodically by the host micro. If software fails to restart the timer, the watchdog resets the processor. Restarting the timer takes considerable processing, making it unlikely that it would occur accidentally, as might happen for a simple pin-strobe configuration of typical watchdog IC.

The watchdog is disabled after reset occurs. It stays disabled until initialized by the host processor. The initialization requires the watchdog clock mode to be selected (see Figure 1) and the 7-bit time-out value to be set. As soon as the time-out is written, the watchdog begins operations and can not be stopped; also, the time-out value and or clock source can no longer be changed.

The two clock sources available for the watchdog are the internal 32.768kHz clock and the CLK_{OUT} signal. When operating from the 32.768kHz source, the time-out interval is programmable from 7.8125ms to one second with resolution of 7.8125ms. The internal 32.768kHz clock is running all the time, therefore the time-out duration is fixed and predictable.

When operating from the CLK_{OUT} signal the time-interval is programmable between 256 and 32768 cycles of CLK_{OUT} with resolution of 256 cycles. The actual time-out duration

is variable and depends both on the frequency of CLK_{OUT} signal and the amount of time target micro spends in the STOP mode, when the CLK_{OUT} signal is also stopped.

These two clock modes, together with the programmable time-out value, allow the SH3003 exceptional flexibility, previously unattainable by existing discrete watchdog solutions.

The watchdog timer is kept from timing out by periodic reload of the time-out value, triggered by a write of a code byte to the Watchdog Reload Register. As a further safety measure, there are two different and alternating code bytes that should be written to the same Watchdog Reload Register. The code values are 0x5A and 0xC3. The timer is reloaded after every write of a single code byte.

The code byte should be written to the Watchdog Reload Register, or reset is activated when the watchdog timer expires. Also, reset is initiated immediately if the value of the code byte is incorrect or out of sequence. When the watchdog triggers the reset, its duration is 12ms.

Using two separate software routines, each to write one of the code values, results in the highest level of system security. These routines must execute in the correct order. It is unlikely that runaway code could manage this. In addition, this design makes it difficult for the code to become stuck in a tight loop resetting the watchdog.

POWER MANAGEMENT

Application Information (continued)

Clock Management System

The SH3003 provides a flexible tool for creating and managing clocks, a versatile and accurate “any frequency” clock synthesizer (see Figure 4). It is capable of generating any frequency in the range of 62.5kHz to 16.0MHz, with worst-case resolution of 0.0256% (256ppm). The internal 32.768kHz clock can also be routed to the CLKOUT pin (and HF oscillator stopped for energy savings).

The objectives, features, and behavior of the Clock Management System are aimed towards the systems that utilize a microcontroller, a microprocessor, a DSP or an ASIC.

The SH3003 permits the automatic sensing of the intentions of the host processor, an industry first. The SH3003 shuts down its clock output when it senses that the host processor issued a STOP instruction.

Subsequently, the SH3003 idles, consuming less than 10µA. As soon as the host exits the STOP mode, the SH3003 instantaneously starts to supply a stable clock (< 2µs wake-up). A typical system, constructed with a ceramic resonator or a crystal as the frequency determining element, must wait at least several hundred microsec-

onds (for a resonator), or as much as 100ms or more (for a HF crystal), to re-start the oscillator. The SH3003 allows the response to and service of an event to finish with a speed previously unattainable for a simple microprocessor. A system with a traditional clock approach may be as much as 100x – 10,000x slower.

Clock Generator Operation

The frequency synthesizer in the SH3003 is constructed from the 2:1 tunable 8.0 –16.0 MHz HF oscillator followed by a programmable “power-of-two” post-divider (see Figure 4).

The Clock Source selector and the programmable post-scale divider allow instantaneous switching between the 32.768kHz internal clock and divided-down HF oscillator output. There is no settling or instability when the switch occurs. This is a preferred method for clock control in computing systems, when the large ratio between high and low frequency of operations allows for correspondingly large and instantaneous savings in power consumption.

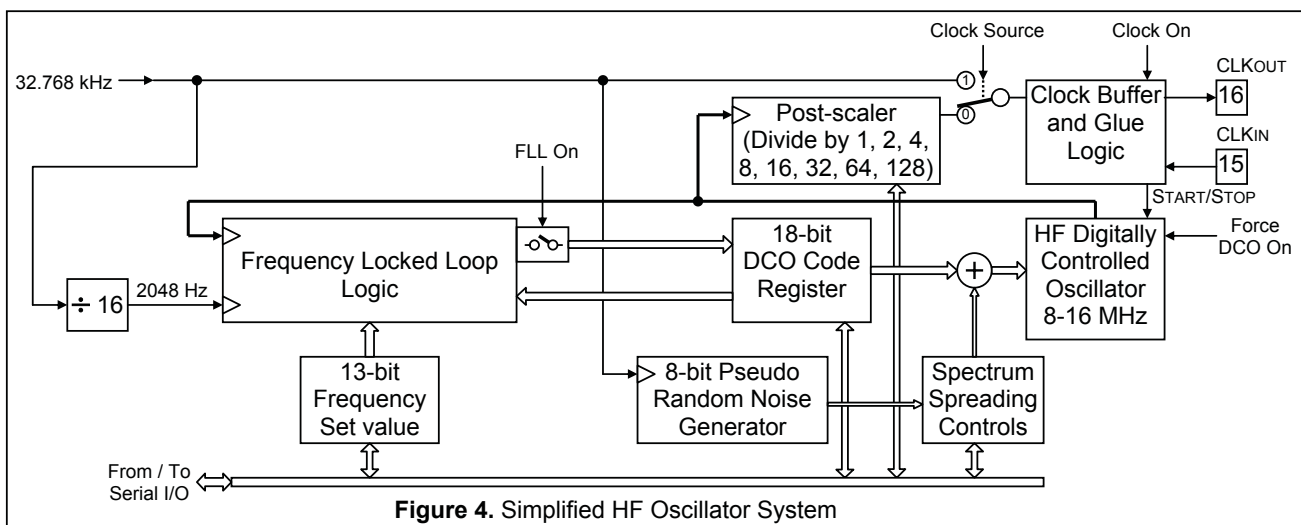

Figure 4. Simplified HF Oscillator System

POWER MANAGEMENT**Application Information (continued)****Clock Generator Operation (continued)**

When the HF oscillator is operating alone, it can set the frequency of the clock on the CLKOUT pin to $\pm 0.025\%$, and maintain it to $\pm 0.5\%$ over temperature. This compares favorably with the typical $\pm 0.5\%$ initial clock accuracy and $\pm 0.6\%$ overall temperature stability of ceramic resonators. The SH3003 replaces the typical resonator, using less space and providing better performance and functionality.

The HF oscillator can also be locked to the internal 32.768kHz signal. The absolute accuracy and stability of the HF clock depends on the quality of the 32.768 kHz internally generated clock; the low-frequency (LF) Oscillator System is described later in this document. When the Real-Time Clock module of the SH3003 is used for high-accuracy timekeeping, an external 32.768 kHz crystal used as a reference for RTC provides excellent accuracy and stability for the Clock Management System.

The SH3003 employs a Frequency Locked Loop (FLL) to synchronize the HF clock to the 32.768kHz reference. This architecture has several advantages over the common PLL (Phase Locked Loop) systems, including the ability to stop and re-start without frequency transients or instability, and with instant settling to a correct frequency. The conventional PLL approach invariably includes a Low-Pass Filter that requires a long settling time on re-start.

The primary purpose of the FLL is the maintenance of the correct frequency while the ambient temperature is changing. As the temperature drift of the HF oscillator is quite small, any corrective action from the FLL system is also small and gradual, commensurate with the temperature variation.

The FLL system in the SH3003 is unconditionally stable. To set a new frequency for the FLL, the host processor writes the 13-bit Frequency Set value. The resulting output frequency is calculated using simple formulas:

[1] and [2] (reference frequency is 32.768kHz):

$$\mathbf{FOSC = 2048 \text{ Hz} * (\text{Frequency Set value} + 1) \text{ [1]}}$$

$$\mathbf{FOUT = FOSC / (\text{Post-divider setting}) \text{ [2]}}$$

For example, a post-divider setting of $\div 8$ and the Frequency Set value of 4000 (0x0FA0) produce an output frequency of 1.024MHz.

Programmable Spectrum Spreading

Most commercial electronic systems must pass regulatory tests in order to determine the degree of their Electro-magnetic Interference (EMI) affecting other electronic devices. In some cases compliance with the EMI standards is costly and complicated.

The SH3003 offers a technique for reducing the EMI. It can be a part of the initial design strategy, or it can be applied in the prototype stage to fix problems identified during compliance testing. This feature of the SH3003 may greatly reduce the requirements for radiofrequency shielding, and permits the use of simple plastic casings in place of expensive RFI-coated or metal casings.

The SH3003 employs Programmable Spectrum Spreading in order to reduce the RF emissions from the processor's clock. There are five possible settings; please see Table 2 for operating and performance figures in the 8-16MHz range.

POWER MANAGEMENT

Application Information (continued)

Programmable Spectrum Spreading (continued)

Setting			Spreading Bandwidth kHz	Peak EMI Reduction (guaranteed db)	Peak EMI Reduction (measured db)
En	CFG1	CFG0			
0	x	x	Off	0	0
1	0	0	32	-3	-3
1	0	1	64	-6	-7
1	1	0	128	-9	-10
1	1	1	256	-12	-15

Table 2 - EMI reduction with Spectrum Spreading

Spectrum Spreading is created by varying the frequency of the HF oscillator with a pseudo-random sequence (with a zero-average DC component). The Maximum-Length Sequence (MLS) 8-bit random number generator, clocked by 32.768kHz, is used. Only four, five, six, or seven bits of the generated 8-bit random number are used, according to the configuration setting.

Maximum fluctuations of the frequency depend on the selected frequency range and the position within the range. Selecting the HF oscillator frequency to be near the high end of the range limits the peak variations to 0.1%, ±0.2%, ±0.4%, or ±0.8% (corresponding to the configuration setting).

POWER MANAGEMENT

Application Information *(continued)***Special Operating Modes**

The SH3003 can operate stand-alone, without connections to the In and Out terminals of the host's oscillator. For example, a bank of SH3003 chips can generate several different frequencies for simultaneous use in the system, all controlled by a single micro (and possibly sharing one 32.768kHz crystal by chaining the CLK32 pin to XIN pin on the next device). In this case the CLK_{IN} pin should be connected to VSS. The clock output on the CLK_{OUT} pin is continuous; the correct operating mode is automatically recognized by the SH3003.

A microcontroller may not have a STOP command. With the SH3003, this controller can do a "simulated" STOP by issuing an instruction to the SH3003 to stop the clock. This command is accepted only if the Periodic Interrupt / Wakeup Timer has started (otherwise, once the system is put to sleep, it would never wake up again). This mode of operations is only possible if the host processor is capable of correct operations with clock frequency down to zero, and keeps all of the internal RAM alive while the clock is stopped.

Real Time Support

The SH3003 has two support modules that are specifically designed for various real time support functions. They are the Real-Time Clock and the Periodic Interrupt / Wakeup Timer. Both of these units as well as other functions of the SH3003 depend on the internal 32.768kHz clock for accuracy.

The SH3003 allows a trade-off between the cost of a system and its accuracy. For some devices, a single SH3003 without any support components provides sufficient accuracy.

These units can operate with processor clock accuracy of $\pm 0.5\%$ and the accuracy of the real-time system of $\pm 3\%$.

At the other end of the spectrum, with one external component (a 32.768kHz crystal), the SH3003 can provide a processor clock accuracy of $\pm 256\text{ppm}$ ($\pm 0.0256\%$) and the accuracy of the real-time system of $\pm 4\text{ppm}$ ($\pm 0.0004\%$).

Low Frequency (LF) Oscillator System

This module provides the 32.768kHz clock to all internal circuits and to the dedicated output pin, CLK32. If enabled, the CLK32 output continues normal operations when VDD is absent and backup power is available.

When the power is first applied to the SH3003, the RC oscillator takes over. It supplies the 32.768 kHz clock for start-up and initialization. However, if the CLKSEL pin is set high, then the crystal oscillator is enabled. Once the crystal has started and stabilized, the internal 32.768 Hz clock switches to the very accurate crystal frequency; see Figure 5.

Just like the VBO value for the Reset circuit, the default calibration values for the RC oscillator are loaded on power-up from the factory-programmed non-volatile memory. They can be re-programmed at any time or they can be permanently protected from any changes by setting the Lock flag or a write-protect flag. Factory calibration brings the frequency of the RC oscillator within \pm % of the 32.768kHz for the internal reference resistor, and \pm 2% for the external 1M Ω 1% resistor, over the entire temperature and supply voltage range.

The frequency of the RC oscillator can be tuned or modulated by varying the external reference resistor, which should be located as close as possible to RREF, pin 9.

The crystal oscillator has the useful feature of adjustable load capacitors. It permits tuning of the circuit for initial tolerance of the crystal (often \pm 20ppm) as well as an adjustment for the required load capacitance (with possible variations from the PCB layout). While the oscillator was designed for a crystal with a nominal load capacitance of 12.5pF, the circuit accommodates any value from \sim 7pF to 22pF (depending on parasitics of the layout). All of these corrections can be performed when the part is already installed on the PCB, in the actual circuit.

The default value for load capacitance (12.5pF) loaded on power-up from the factory-programmed nonvolatile memory can be re-programmed at any time (following a secure process of unlocking the load capacitance value register and immediately writing a new setting), or it can be completely protected from any changes by a permanent write-protect flag. This adjustment can set the frequency of the crystal oscillator to within \pm 4ppm of the ideal value. As a reference, a typical 32.768kHz crystal changes its frequency 4ppm for a 10 $^{\circ}$ C change in temperature.

Since the temperature characteristics of crystals are well known and stable, the host processor is free to implement an algorithm for temperature compensation of the crystal oscillator using the adjustable load capacitors, with resulting accuracy of \pm 4ppm over the entire temperature range.

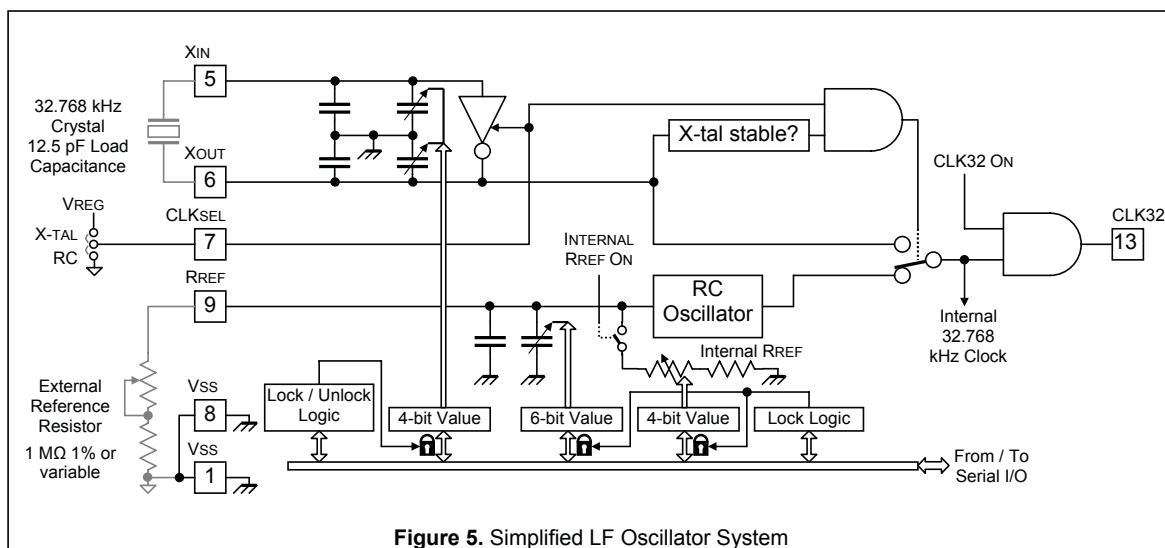
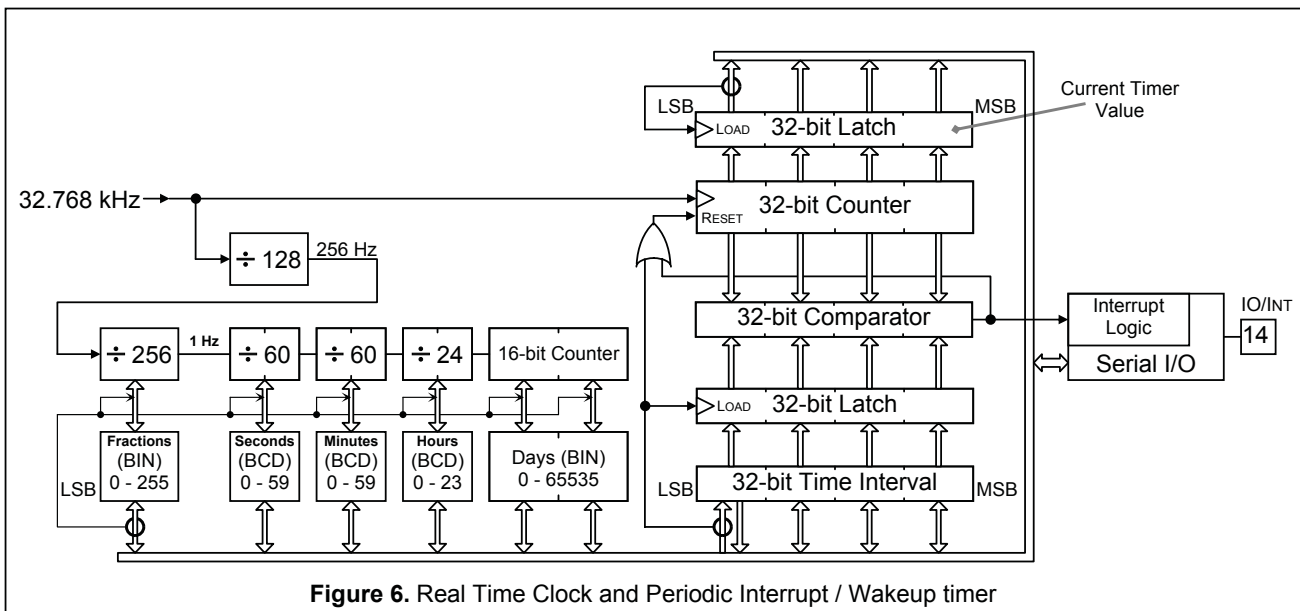

Figure 5. Simplified LF Oscillator System

Real-Time Clock

Using the $\pm 4\text{ppm}$, 32.768kHz clock from the LF oscillator, the Real-Time Clock module keeps time with a maximum error as low as two minutes per year. This compares favorably with a conventional error of two minutes per month for the typical RTC chip.

The hardware of the Real-Time Clock is capable of 179-years of calendar operations (see Figure 6). All counting-chain values are loaded at the same time into corresponding registers when the Fractions register is read. All values from registers are loaded into the counting-chain when the Fractions register is written. The RTC continues normal operations when VDD is absent, if backup power is available.



POWER MANAGEMENT**Application Information (continued)****Periodic Interrupt/Wakeup Timer**

Simple and versatile, the Periodic Interrupt/Wakeup Timer can be used to create very accurate recurring interrupts for use by the host micro. With some minimal software support from the host processor, it can also be used to create alarms, with practically unlimited duration.

While the timer is running, the host processor may be halted, consuming no energy. The interrupt wakes up the processor, which can perform the requisite task and go back to sleep, until the next periodic interrupt. This mode of operation can achieve extremely low average power consumption. A 32-bit counter clocked by 32.768kHz, producing a minimum interval of 30.5 μ s and the maximum interval of 36.4 hours, creates the Timer.

After reset, the timer is stopped until the new value for the time interval is written into the 4-byte Time Interval register. When the least significant byte (LSB) is written, the whole value is moved to the Time Interval latch, the counter is reset and starts to increment with the 32.768 kHz clock.

When the 32-bit comparator detects a match, an interrupt is generated and the counter is reset and starts the next timing cycle.

Although the counter cannot be written to, the current value from the counter can be read at any time. The whole 32-bit value is loaded into the 32-bit Current Timer Value latch when the least significant byte is read. This prevents errors stemming from the finite time between the readings of individual bytes of the current value.

Auxillary Functions**Scratchpad RAM**

Four bytes of general-purpose RAM reside on the SH3003.

Voltage Regulator

Pin VREG can be used as a nominal 2.20V reference voltage or a supply source for small loads (< 2mA). A bypass capacitor may be necessary between this pin and VSS if the load generates large current transients or a low ripple reference is required.

POWER MANAGEMENT**Application Information (continued)****Interrupt and Serial Interface**

A single line is used to convey bi-directional information between the SH3003 and the processor, and as the interrupt line to the processor.

The polarity of the interrupt signal is programmable. The SH3003 and the host microcontroller communicate using a single wire, bi-directional asynchronous serial interface. The bit rate is automatically determined by the SH3003. At the fastest possible rate, a read or write access of a single byte from the register bank takes 5 μ s.

The SH3003 contains thirty-six addressable registers located at 0x00–0x1F. Some of these registers are accessed through a page operation. Pin 14, IO/Int, is the serial communications interface and interrupt output pin. This pin is internally weakly pulled to the opposite of the programmed interrupt polarity. For example, if interrupt is programmed to be active low, this pin is weakly pulled to VDD when inactive.

As shown in Figure 7, the SH3003 and the host communicate with serial data streams. The host always initiates communication. A data stream consists of the following (in this order):

- 3-bit start field
- 3-bit read/write code
- 5-bit address field
- 1 guard bit
- 8-bit data field
- 2 parity bits

Plus, for write streams only:

- 1 guard bit
- 2 acknowledge (ACK) bits

The 3-bit start field (1,0,1 or 0,1,0, depending on interrupt polarity) uses the middle bit to determine the bit period of the serial data stream.

The 3-bit read/write code consists of 1,1,0 for a read, or 0,1,1 for a write. This protects against early glitches that might otherwise put the interface into an invalid read or write access mode.

The 5-bit address field contains the address of the register. A single guard bit gives the interface a safe period in which to change data direction. The value of a guard bit does not matter. The 8-bit data field is written to (read from) the register.

Two parity bits: The first parity bit is high when there are an odd number of bits in the read/write, address and data fields; the second parity bit is the inverse of the first.

For write streams only, a guard bit is appended to the stream (to allow safe turnaround), and then two acknowledge bits, which are a direct copy of the parity bits, are driven back to the host to indicate a successful write access.

Two guard bits are appended to the end of the access stream (read or write). The host can not start the next access before receiving these bits.

The interface is self-timed based on the duration of the start bit field, and communication can take place whenever CLKout is active, either at 32.768kHz or at a higher frequency. If the host microcontroller is running synchronously to the CLKout generated by the SH3003 (which should generally be the case), then a minimum of four CLKout cycles per bit are required to maintain communication integrity. If the host's serial interface is asynchronous to CLKout, then a minimum of 52 cycles per bit are necessary. A maximum of 1024 CLKout cycles per bit field is supported.

Table 3 displays the minimum and maximum bit periods for the serial communications for CLKout frequencies of 16 MHz, 8MHz, and 2MHz.

POWER MANAGEMENT

Application Information (continued)

Interrupt and Serial Interface (continued)

CLKOUT Frequency	Minimum Bit Period (host synchronous to CLKOUT)	Minimum Bit Period (host Asynchronous to CLKOUT)	Maximum Bit Period
16MHz	250ns	3.25µs	63.9µs
8MHz	500ns	6.5µs	127µs
2MHz	2µs	26µs	511µs

Table 3 - Minimum/Maximum Serial Bit Timing

Interrupt Interface

The serial communications line to the SH3003 (Pin 14, IO/Int) also serves as the interrupt to the host microcontroller. The polarity of the interrupt is software programmable using the interrupt polarity bit (bit 6) of the IPol_RCtune register (R0x11). This pin is asserted for four cycles of CLKout, and then returns to the inactive state.

The interrupt line is used by the Periodic Interrupt/Wake-up Timer to interrupt the host when it reaches its end of count.

POWER MANAGEMENT

Application Information (continued)

IO/INT Timing Scenarios

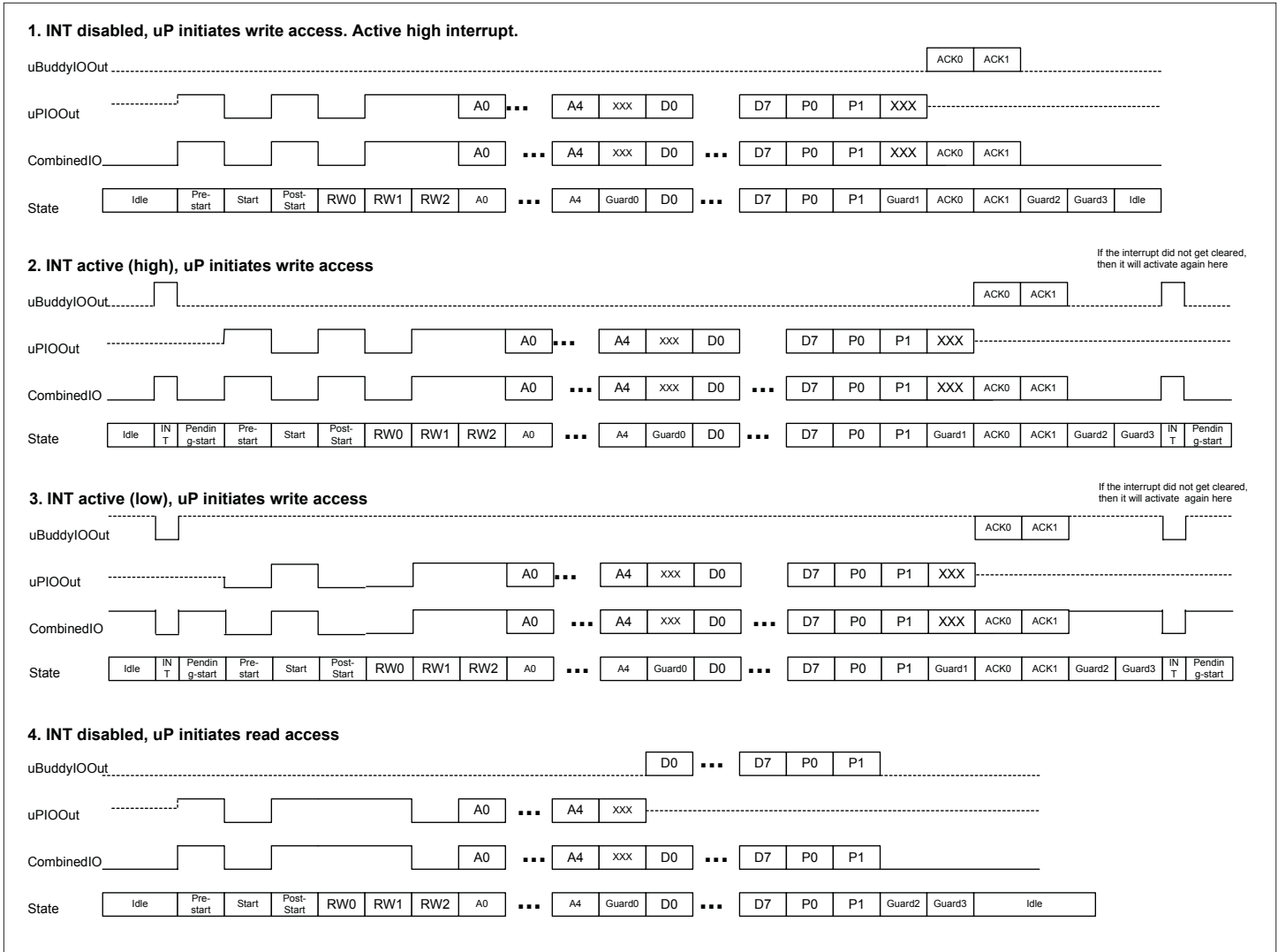
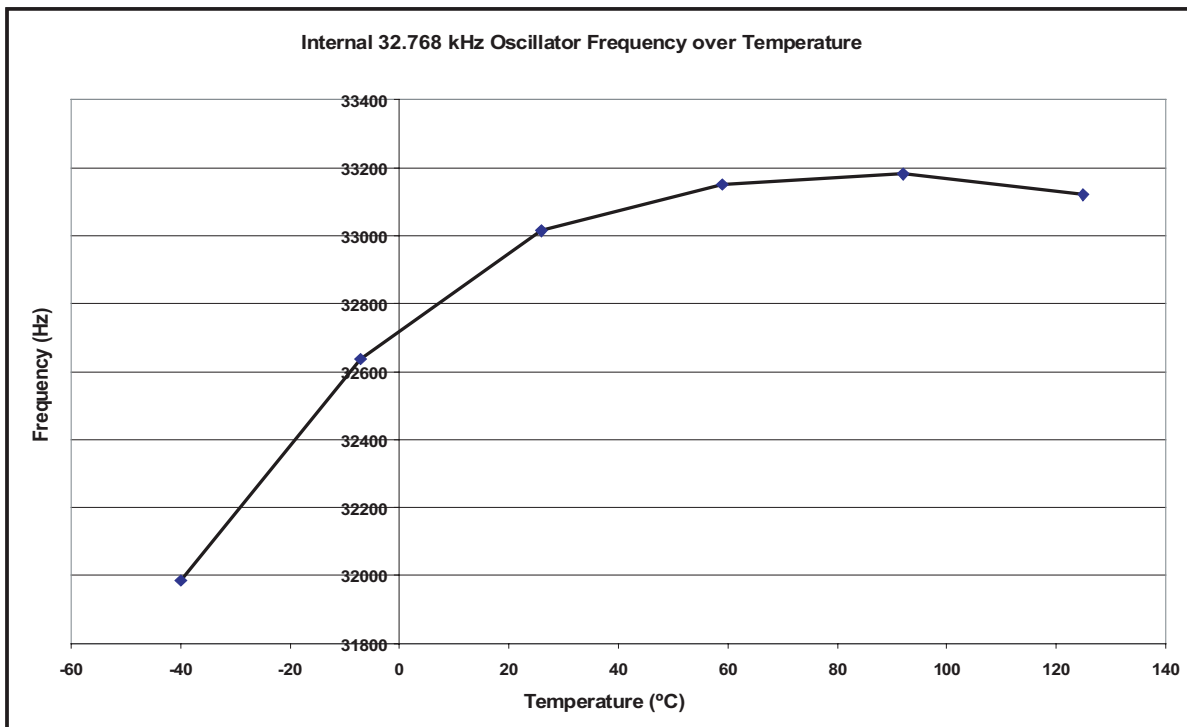
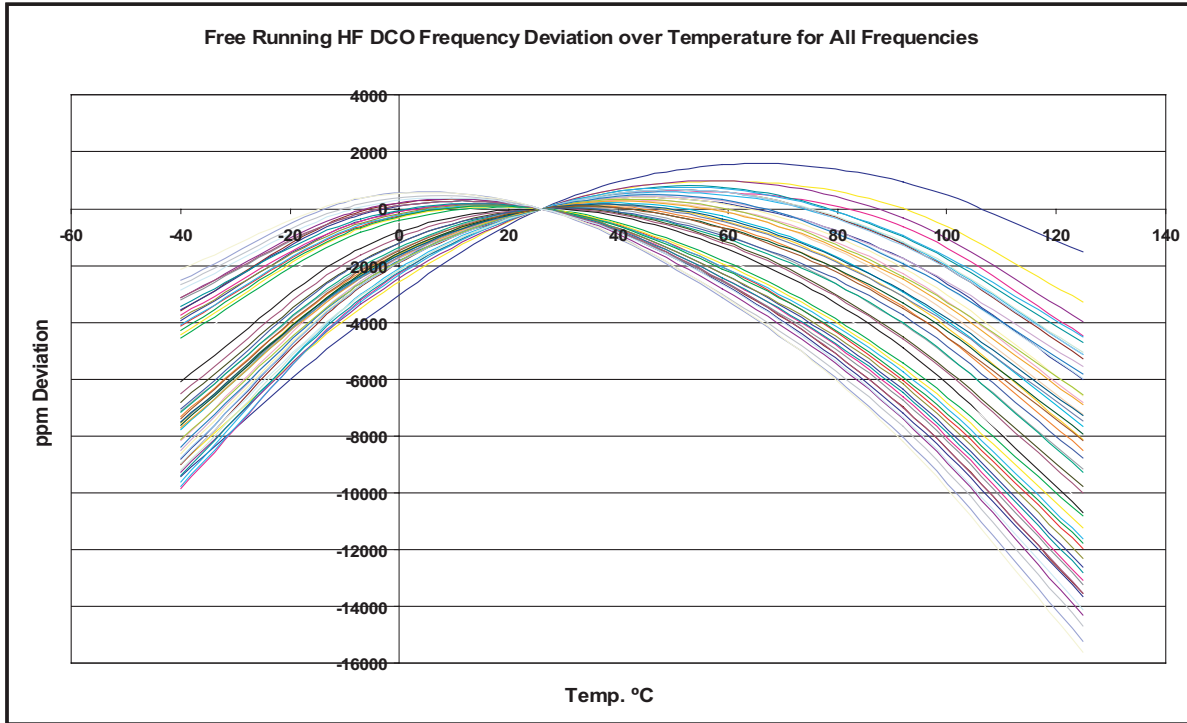
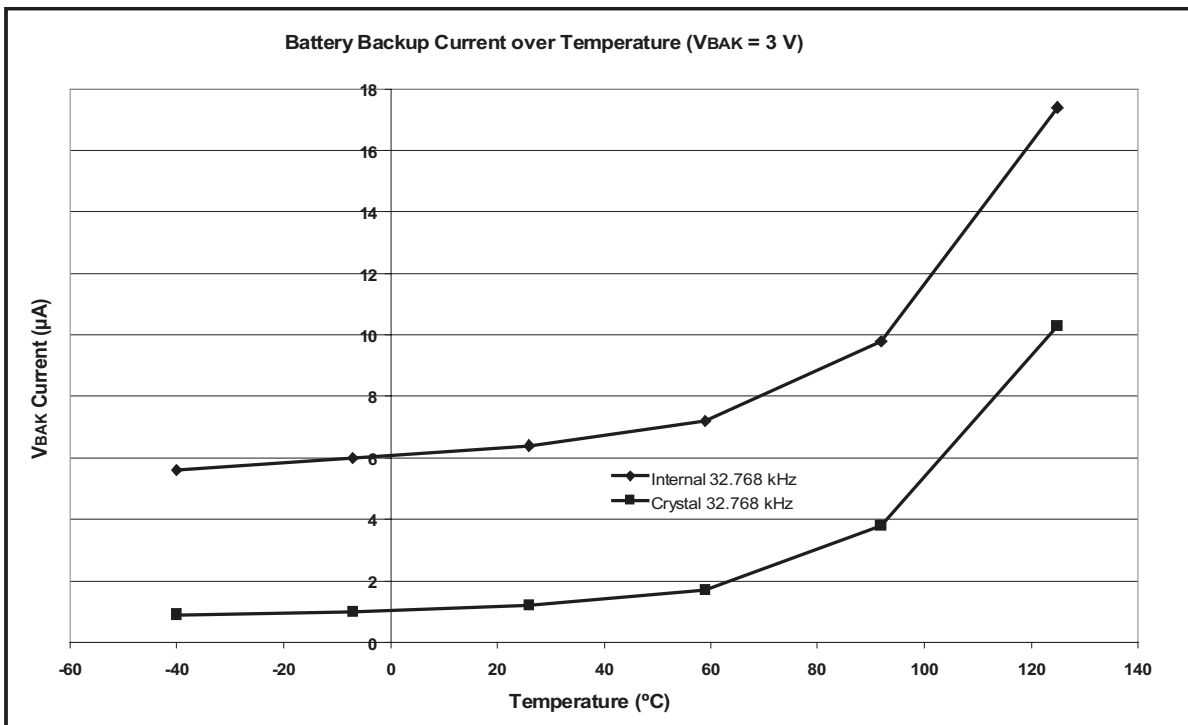
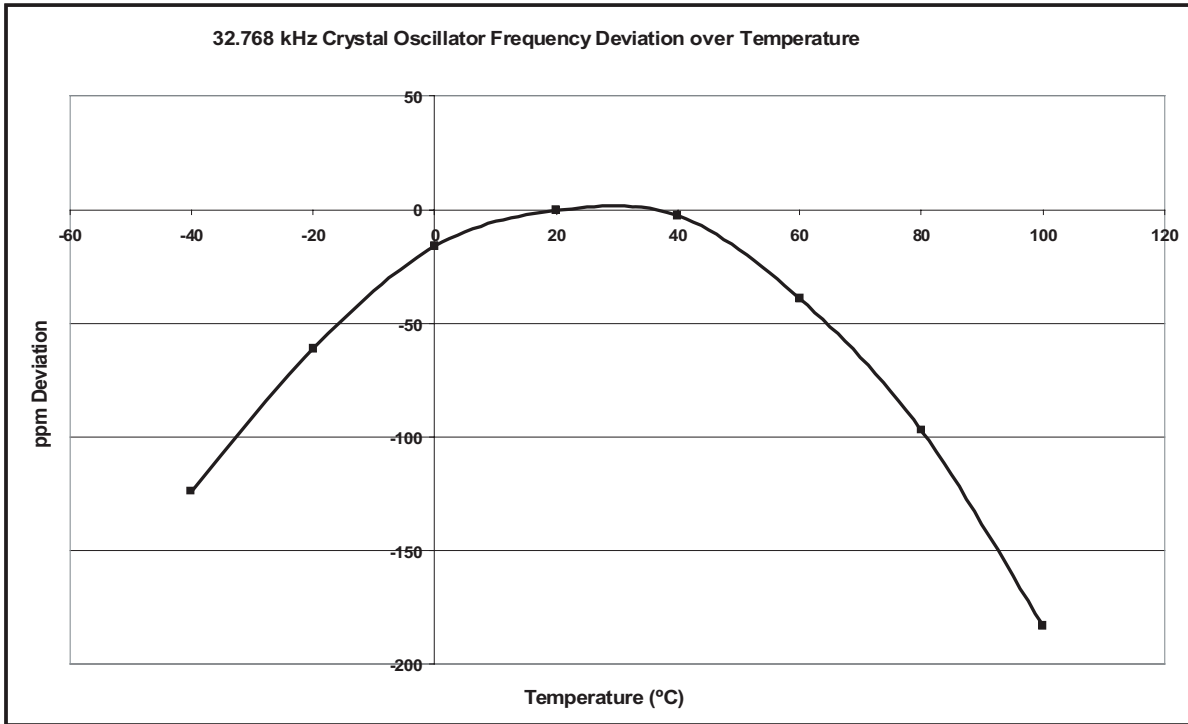

Figure 7. Serial Communication Timing Diagram





POWER MANAGEMENT

Typical Characteristics (continued)

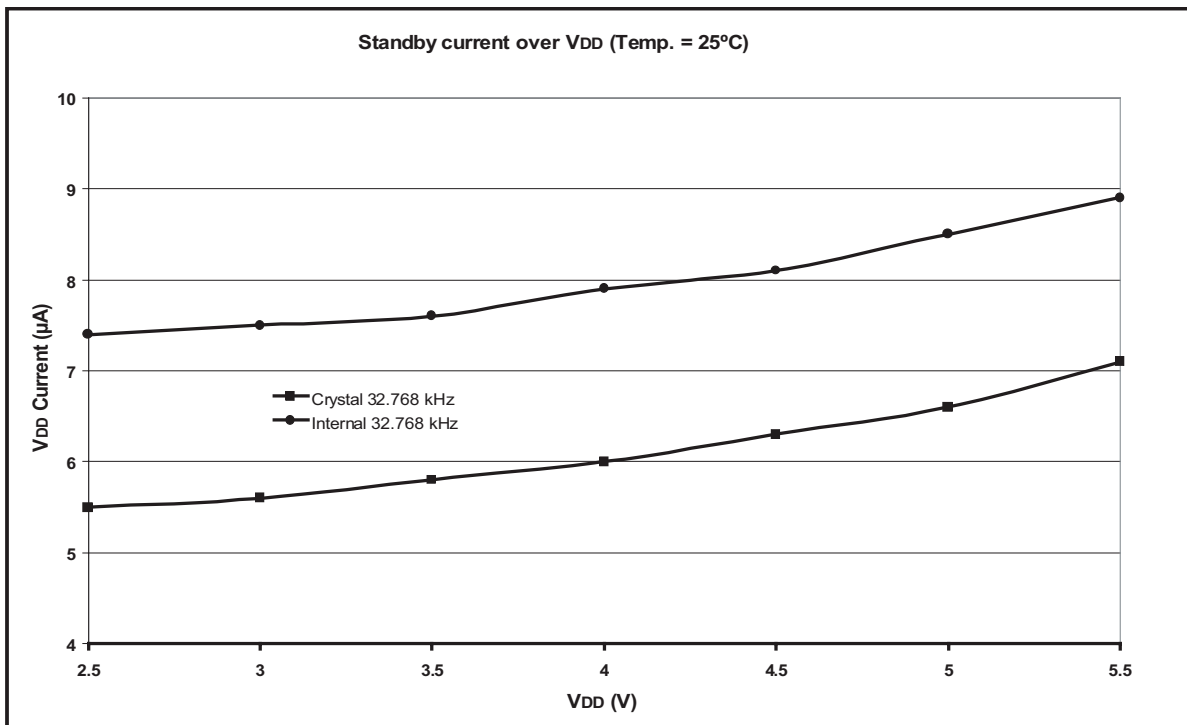
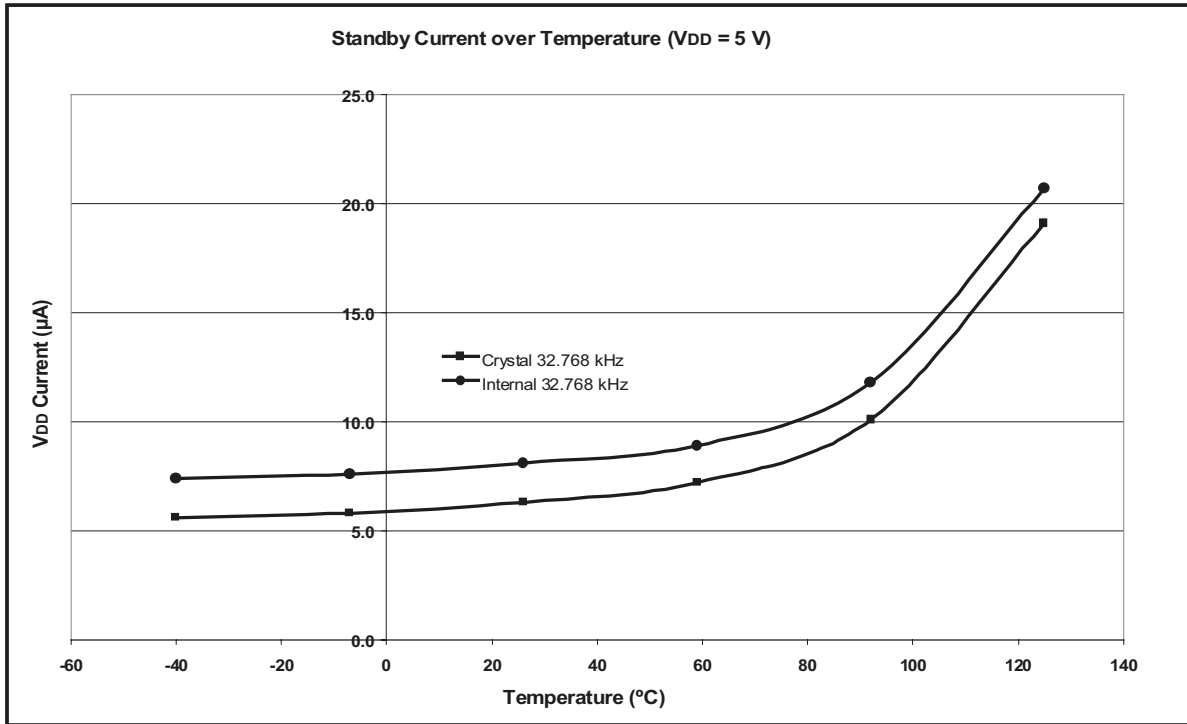

POWER MANAGEMENT

Typical Characteristics (continued)

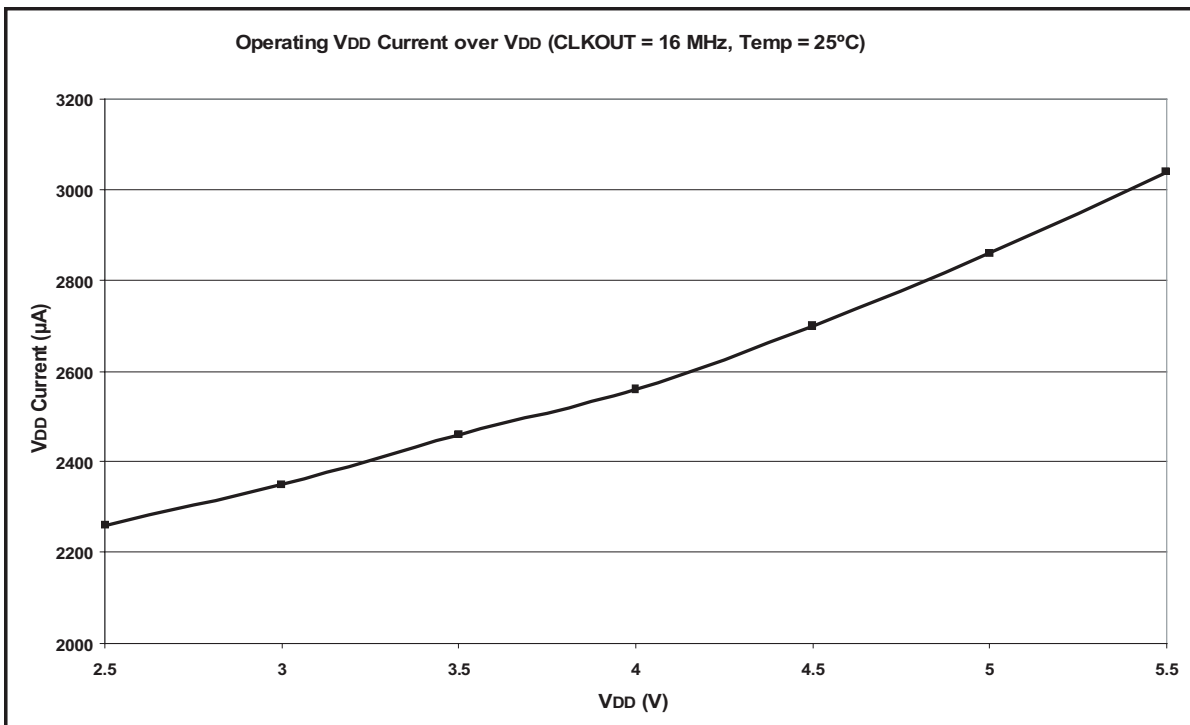
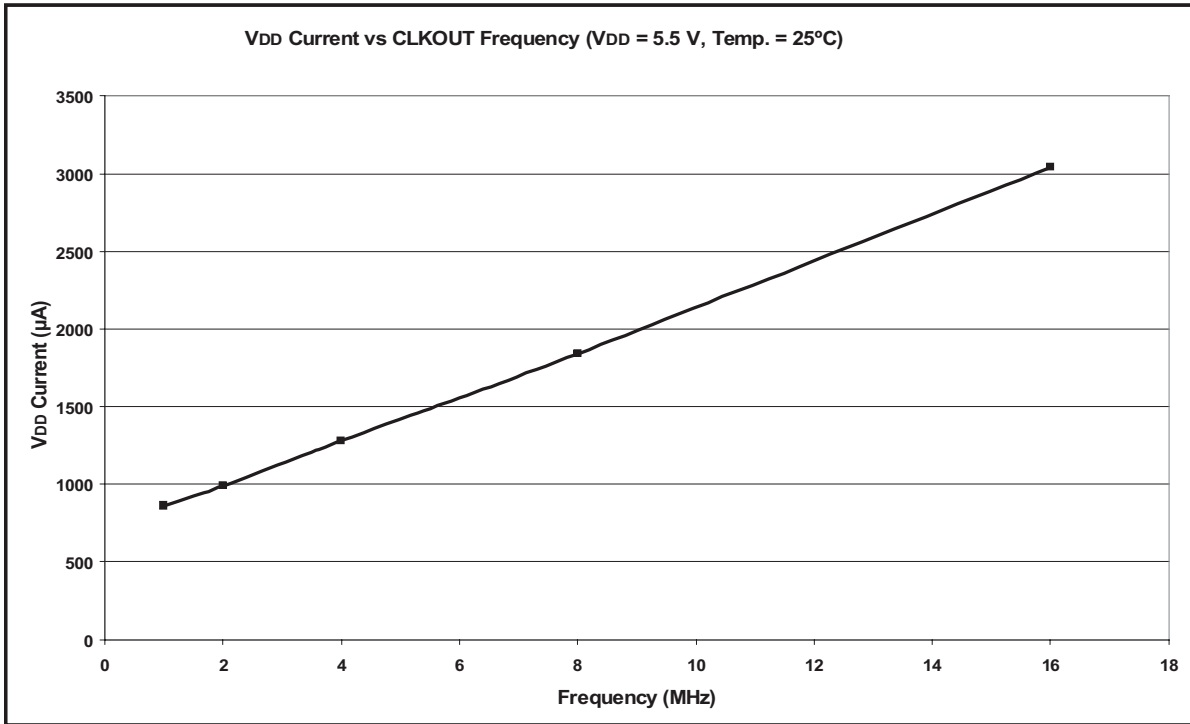

POWER MANAGEMENT

Typical Characteristics (continued)

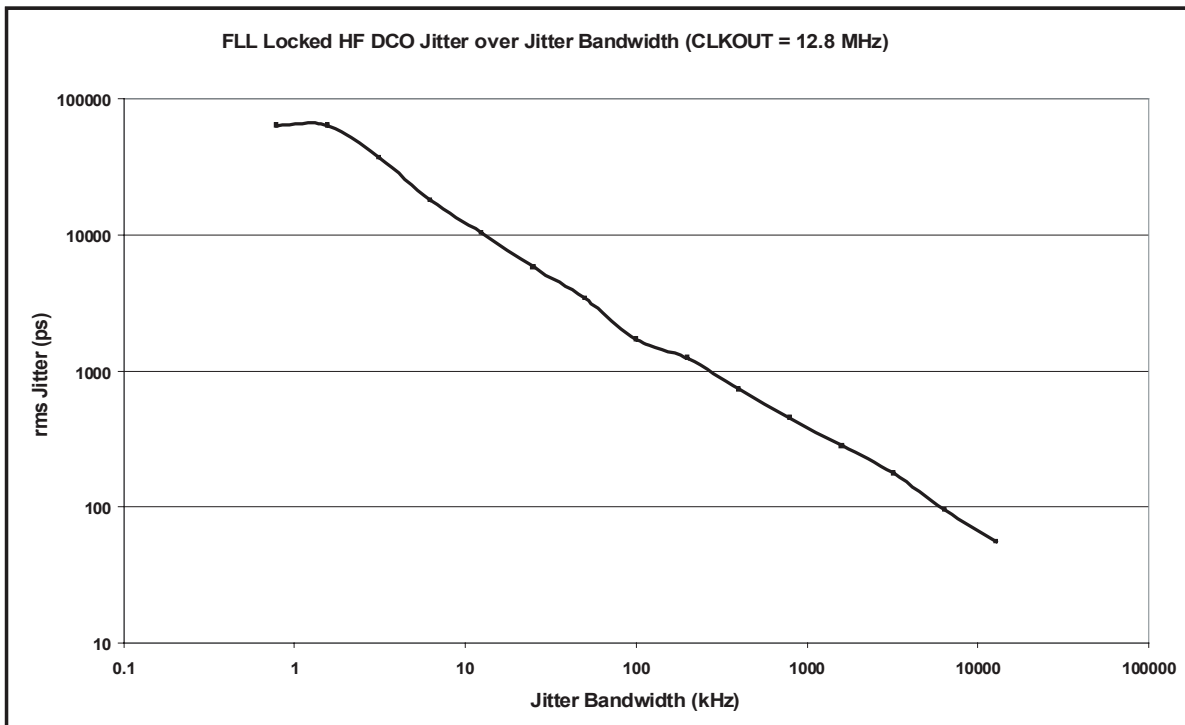
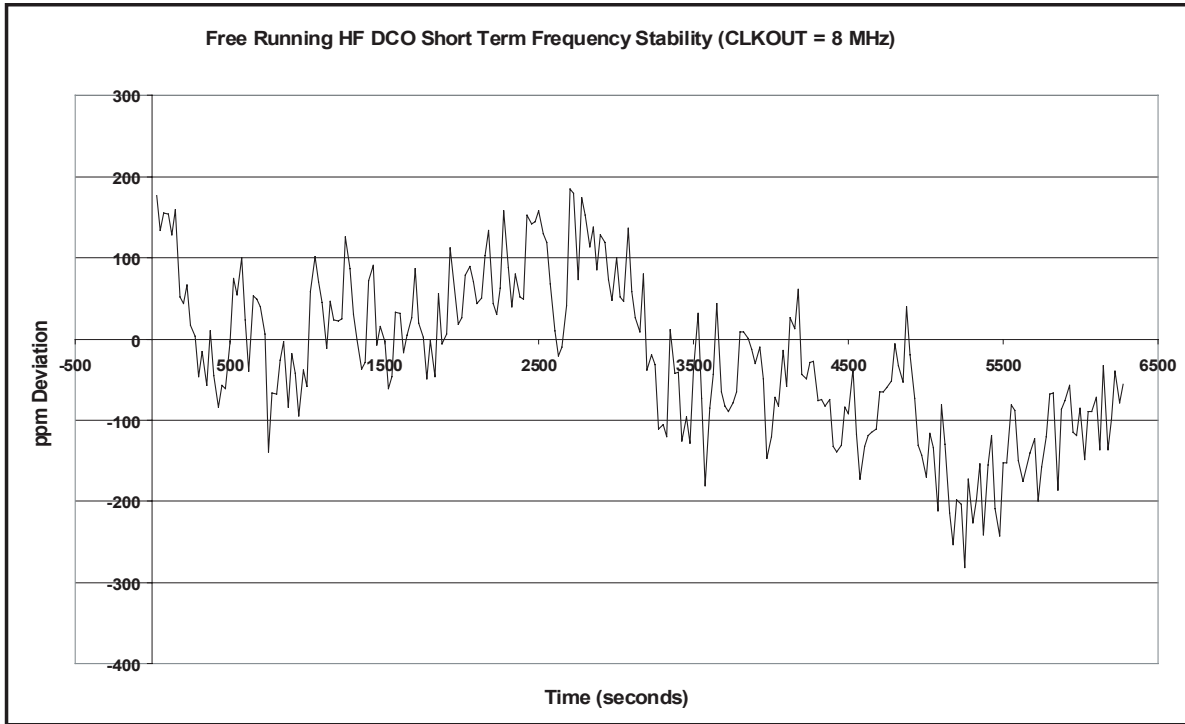

POWER MANAGEMENT

Outline Drawing - MLP 3 x 3 mm 16 pins

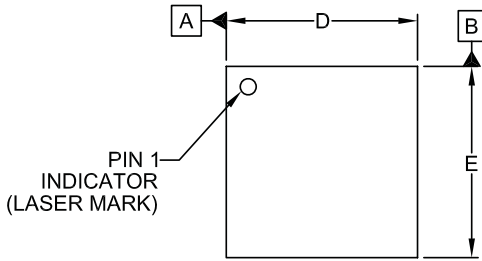

DIM	INCHES			MILLIMETERS		
	MIN	NOM	MAX	MIN	NOM	MAX
A	.031	-	.040	0.80	-	1.00
A1	.000	-	.002	0.00	-	0.05
A2	-	(.008)	-	-	(0.20)	-
b	.007	.009	.012	0.18	0.23	0.30
D	.114	.118	.122	2.90	3.00	3.10
D1	.055	.061	.065	1.40	1.55	1.65
E	.114	.118	.122	2.90	3.00	3.10
E1	.055	.061	.065	1.40	1.55	1.65
e	.020 BSC			0.50 BSC		
L	.012	.016	.020	0.30	0.40	0.50
N	16			16		
aaa	.003			0.08		
bbb	.004			0.10		

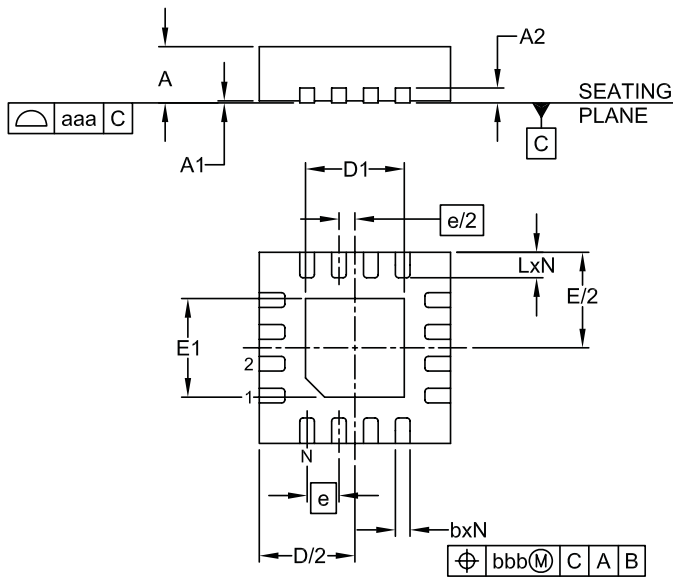

NOTES:

1. CONTROLLING DIMENSIONS ARE IN MILLIMETERS (ANGLES IN DEGREES).
2. COPLANARITY APPLIES TO THE EXPOSED PAD AS WELL AS THE TERMINALS.

POWER MANAGEMENT

Land Pattern - MLP 3 x 3 mm 16 pins

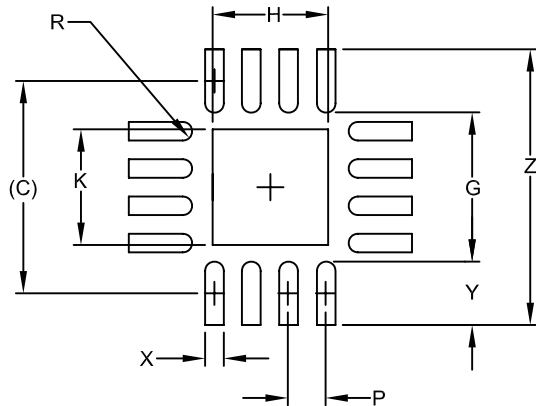

DIMENSIONS		
DIM	INCHES	MILLIMETERS
C	(.114)	(2.90)
G	.083	2.10
H	.065	1.65
K	.065	1.65
R	.005	0.12
P	.020	0.50
X	.010	0.25
Y	.031	0.80
Z	.146	3.70

NOTES:

1. THIS LAND PATTERN IS FOR REFERENCE PURPOSES ONLY. CONSULT YOUR MANUFACTURING GROUP TO ENSURE YOUR COMPANY'S MANUFACTURING GUIDELINES ARE MET.
2. DO NOT PLACE VIAS BETWEEN THE CORNER LEADS INSIDE THE 3X3MM PACKAGE FOOTPRINT.
3. THERMAL VIAS IN THE LAND PATTERN OF THE EXPOSED PAD SHALL BE CONNECTED TO A SYSTEM GROUND PLANE. FAILURE TO DO SO MAY COMPROMISE THE THERMAL AND/OR FUNCTIONAL PERFORMANCE OF THE DEVICE.

Copyright ©2002-2006 Semtech Corporation. All rights reserved. Semtech, the Semtech logo, MicroBuddy, µBuddy, and µB are marks of Semtech Corporation. All other marks belong to their respective owners.

Changes may be made to this product without notice. Customers are advised to obtain the latest version of the relevant information before placing orders.

LIMITED LICENSE GRANTED: NO WARRANTIES MADE

This specification is provided “as is” with no warranties whatsoever including any warranty of merchantability, fitness for any particular purpose, or any warranty otherwise arising out of any proposal, specification or sample. Any suggestions or comments by Semtech concerning use of this product are opinion only, and Semtech makes no warranty as to results to be obtained in any specific application. A license is hereby granted to reproduce and distribute this specification for internal use only. No other license, expressed or implied to any other intellectual property rights is granted or intended hereby. Authors of this specification disclaim any liability, including liability for infringement of proprietary rights, relating to the implementation of information in this specification. Authors of this specification also do not warrant or represent that such implementation(s) will not infringe such rights.

Contact Information

Taiwan Branch	Tel: 886-2-2748-3380 Fax: 886-2-2748-3390	Semtech Switzerland GmbH Japan Branch	Tel: 81-3-6408-0950 Fax: 81-3-6408-0951
Korea Branch	Tel: 82-2-527-4377 Fax: 82-2-527-4376	Semtech Limited (U.K.)	Tel: 44-1794-527-600 Fax: 44-1794-527-601
Shanghai Office	Tel: 86-21-6391-0830 Fax: 86-21-6391-0831	Semtech France SARL	Tel: 33-(0)169-28-22-00 Fax: 33-(0)169-28-12-98
Semtech International AG is a wholly-owned subsidiary of Semtech Corporation, which has its headquarters in the U.S.A.		Semtech Germany GmbH	Tel: 49-(0)8161-140-123 Fax: 49-(0)8161-140-124
www.semtech.com			