

## Understanding pressure measuring with the SX8725

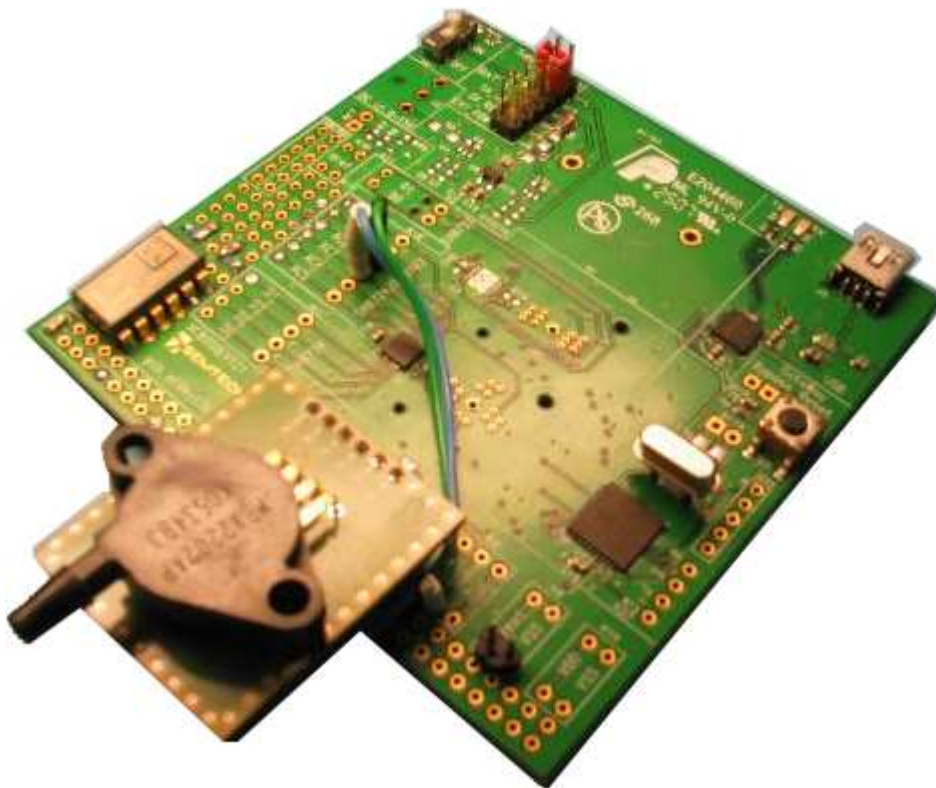
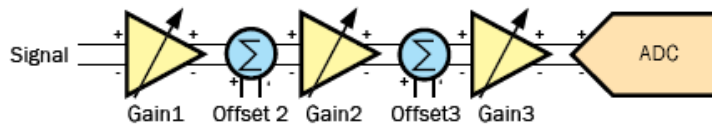

**Table of contents**

Section	Page
I Introduction .....	3
1. General definitions .....	3
1.1. Sensor, transducer .....	3
1.2. Active / Passive.....	3
1.3. Smart sensor .....	3
2. Sensor characteristics .....	4
2.1. Linearity .....	4
2.2. Static characteristics .....	4
2.2.1. Input range .....	4
2.2.2. Accuracy .....	5
2.2.3. Resolution .....	5
2.2.4. Repetability .....	5
2.2.5. Sensitivity .....	5
2.2.6. Offset .....	5
2.2.7. Span .....	5
2.2.8. Drift .....	5
2.2.9. Hysteresis .....	6
2.3. Dynamic characteristics .....	6
2.3.1. Response time .....	6
2.3.2. Settling time .....	7
3. Calibration .....	7
II Sensor signal conditioning .....	8
1. Introduction .....	8
2. Wheatstone bridge .....	8
2.1. Measure a resistance .....	8
2.2. The bridge .....	8
2.3. Null detector .....	9
2.4. Wheatstone bridge with constant voltage drive .....	9
2.4.1. One active element .....	9
2.4.2. Two actives element .....	10
2.4.3. Four active elements .....	10
3. Signal amplification .....	11
4. Bridge connection to the ADC .....	11
III The working principle of pressure sensor .....	13
1. Introduction .....	13
2. Strain gauge pressure sensor .....	13
IV Measuring pressure with SX8725 .....	15
1. Introduction .....	15
1.1. SX8725 features .....	15
2. How to use ZoomingADC™? .....	17
2.1. Overview .....	17

Table of contents

Section	Page
2.2. Gain setting rules .....	18
2.2.1. Using PGA3 .....	18
2.2.2. Using PGA1 and PGA2 .....	19
2.2.3. Distributing the gain over the 3 stages .....	20
2.2.4. PGA settling time .....	21
2.3. Conversion time and choice of the resolution .....	21
3. MPX2202AP sensor .....	23
4. Measuring pressure from MPX2202AP pressure sensor .....	24
4.1. Connection to the sensor .....	24
4.2. Calculating the overall gain .....	24
4.3. Distributing the gain .....	24
4.4. Offset calculation .....	25
4.4.1. PGA2 setting .....	25
4.4.2. PGA3 setting .....	25
4.4.3. PGAsetting .....	25
4.5. Resolution setting and conversion time .....	25
5. SX8725 configuration .....	26
5.1. RegACCfg0 register .....	26
5.2. RegACCfg1 register .....	27
5.3. RegACCfg2 register .....	27
5.4. RegACCfg3 register .....	27
5.5. RegACCfg4 register .....	28
5.6. RegACCfg5 register .....	28
6. Using the evaluation board .....	29
7. Calibration procedure .....	30
7.1. Measure .....	30
7.2. Calibration curve .....	31

## Introduction

Sensors can be found in a large number of applications. From consumer to industrial, automotive to medical, sensors are everywhere.

This guide is intended to give some practical notions on the way of designing the material interface between the sensor and the microcontroller. It focus on circuit used to do the signal conditioning.

In the different chapters, various applications are explained. Most of them are from common industrial application such as industrial measurement. Organized by sensor application, each chapter describes the application, then the sensor is presented and the interface design is explain.

We attempted to provide a useful handbook with technical explanations that are clear. The pressure application is the first chapter available. It will be updated regularly with new applications design using different sensors.

### 1. General definitions

#### 1.1. Sensor, transducer

A sensor is a device that measures or detects a real-world condition, such as motion, heat or light and converts the condition into an analog or digital representation. For example, a photodiode is a sensor capable of converting light into either current or voltage.

A transducer is a device that converts a signal from one physical form to an other such as a photovoltaic panel which convert solar energy to electricity.

Although a sensor is not an energy converters it is often called transducer.

#### 1.2. Active / Passive

An active sensor requires an external source of excitation. It is the case of most resistor-based sensors which requires a current to determine the output voltage.

On the other hand, passive sensors generate their own electrical output signal without requiring external voltage or current. A photodiode doesn't need any excitation source to produce voltage output.

#### 1.3. Smart sensor

With the high level of integration nowadays available, all the functions needed for a complete sensor application are sometimes integrated in the same chip to build a smart sensor. It is possible by this way to miniaturize and to minimize component cost and improve the reliability of the system.

Mixed-signal technology used amplifiers, Analog to Digital converter (ADC) and a microcontroller to do the processing. The figure 1 presents the different kind of integrated sensor it is possible to find from the simple transducer to the complete acquisition system.

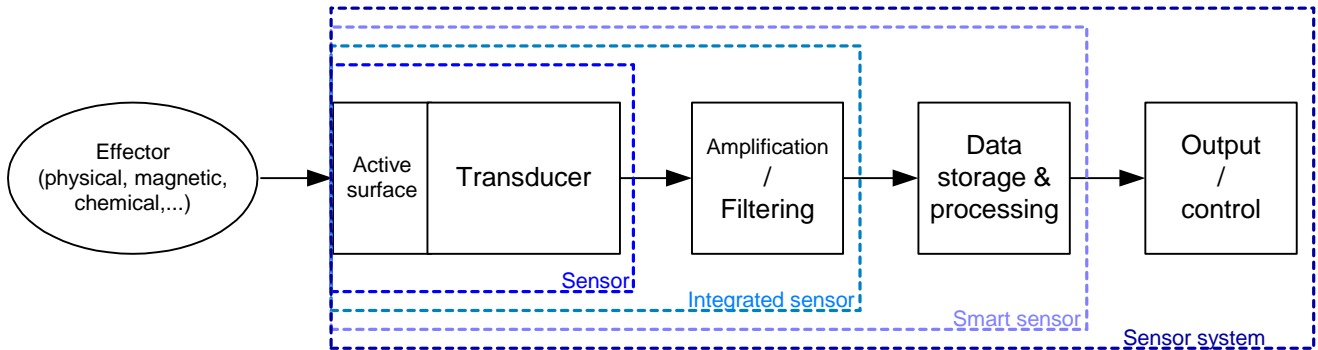

Figure 1. From sensor to system

**2. Sensor characteristics**

**2.1. Linearity**

A linear sensor produces an output value which is directly proportional to the input. A real sensor is never linear but in a determined working range, it can approach a linear function transfer with a good accuracy.

Linearity interest is in the simplicity of the processing: there is few correction to applied to obtain the input value. One way to measure linearity is to use Least Mean Squares (LMS) method which gives the best fit straight line as seen in figure 2.

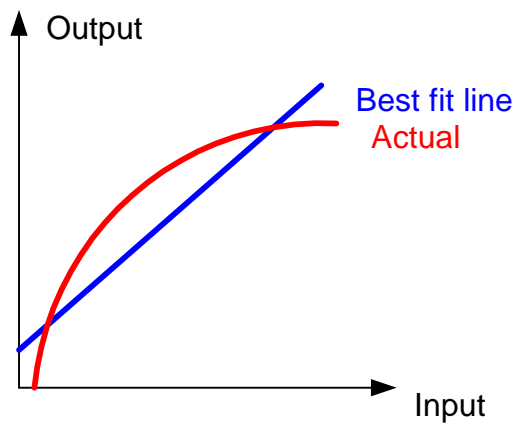

Figure 2. LMS method to obtain best fit line

**2.2. Static characteristics**

**2.2.1. Input range**

ST0002\_01\_US

The input range of the sensor is the maximum and minimum values of applied parameter that can be measured. It works well under this given range. Outside this range, accuracy is not guaranteed, it can even give erratic results or do not work.

#### 2.2.2. Accuracy

The accuracy is the parameter which answer to the question: How well the sensor measures the environment in an absolute sense?

The comparison is done with calibration standards and the result is most of the time in percentage or in absolute for small value of input range.

#### 2.2.3. Resolution

It is the ability of the sensor to see small differences in reading. It must not be confused with accuracy. A temperature sensor can have a resolution of 0.1°C but only an accuracy of 1°C.

Resolution is often determined by the quantization of the analog to digital process.

#### 2.2.4. Repetability

This is the ability of a sensor to repeat a measurement when put back in the same environment.

#### 2.2.5. Sensitivity

The sensitivity of the sensor is defined as the slope of the output characteristic curve or, more generally, the minimum input of physical parameter that will create a detectable output change.

#### 2.2.6. Offset

The offset is defined as the output that will exist when it should be zero.

#### 2.2.7. Span

The span is the output difference when the full input range is applied.

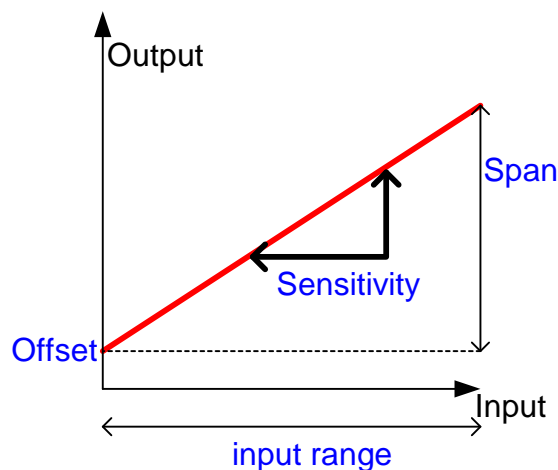

Figure 3. Definitions

#### 2.2.8. Drift

This is the change in a signal over a long periods of time. It is often associated with electronic aging of components or reference standards in the sensor but the drift can also be the effect of temperature. Offset drift (or baseline drift) is a

**ADVANCED COMMUNICATIONS & SENSING** Application note

gradual change in the offset. Span drift (or sensitivity drift) is a change in the sensitivity response. In most sensors, offset drift is a more serious problem than span drift.

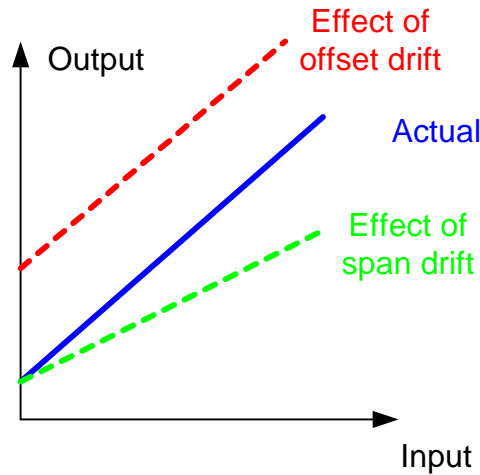

Figure 4. Effect of offset and span drift

### 2.2.9. Hysteresis

A linear up and down input to a sensor, results in an output that lags the input e.g. you get one curve on increasing pressure and another on decreasing. Many pressure sensors have this problem, for better ones it can be ignored.

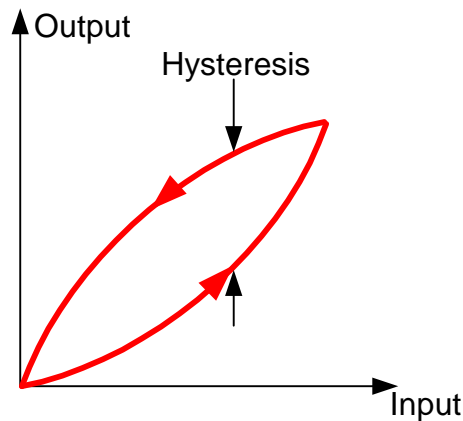

Figure 5. Effect of hysteresis

## 2.3. Dynamic characteristics

The sensor response to a variable input is different from that exhibited when the input signals are constant. The dynamic characteristics are determined by analyzing the response of the sensor to a family of variable input waveforms such as a step, an impulse or a ramp signal.

### 2.3.1. Response time

A step input is applied to the sensor. The response time is the time delay until output signal stabilize.

The response can be different whether it is a first or a second order system.

#### 2.3.2. Settling time

It is the time for the sensor to reach a stable output once it is turned on. Therefore, if you are conserving power by turning off the sensors between measurements, you need to turn on the power and wait a certain time for the sensor to reach a stable output.

## 3. Calibration

Calibration is often needed to improve the sensor output accuracy. The calibration establishes the relationship between the physical measurement variable and the signal variable. A sensor is calibrated by applying a number of known physical inputs and recording the response of the system. A model of the sensor law can then be computed.

For example, a linear system can be put in equation on the form  $Y = a \cdot X + b$ . Therefore, two sets of points are needed at minimum to find  $a$  and  $b$ . With more points the calibration would be indeed more accurate. These coefficients are with a linear sensor the offset and the sensitivity.

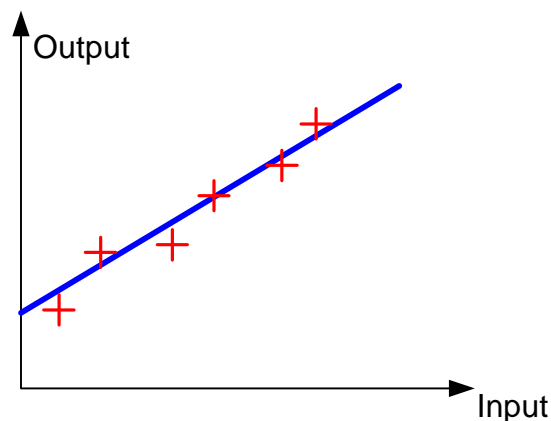

Figure 6. Calibration

A system with a more complex law needs more calibration points. The Least Mean Squares (LMS) algorithm is a solution often used to find a function which best fit a data set.

## Sensor signal conditioning

### 1. Introduction

Because the physical variations in the sensor are small, most of the time the signal of interest is weak. Therefore it had to be conditioned to be exploited. The signal conditioning is a very important part of the signal processing to gain accuracy. It is not only an interface to amplify the signal; it has to remove the noise, to adapt the impedance and all the action to make the signal compatible for the reading.

The Wheatstone bridge is very used with resistive elements sensor. The first section will introduced it and explain its advantages.

### 2. Wheatstone bridge

#### 2.1. Measure a resistance

The most common sensors are resistive elements sensors as they are inexpensive. They are used for measure strain, humidity, pressure, temperature and many others physical phenomena. Their measure principle is based on resistance variation with the physical variable to sense.

Consequently sense the physical phenomena comes to measure the resistance variation of the sensor.

A resistance is easily measured by forcing a current in it and measure the difference voltage. The resistance calculated by Ohms law is given by equation 1.

$$R = \frac{V}{I} \tag{1}$$

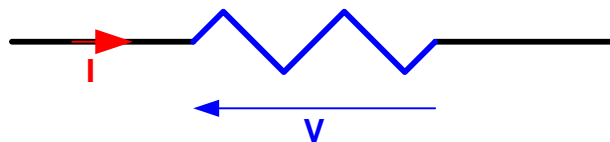

Figure 1. Ohms law

A Wheatstone bridge is a better method for measuring small resistance changes accurately.

#### 2.2. The bridge

Invented by Samule Hunter Christie in 1833 and improved by Sir Charles Wheastone in 1843, the Wheatstone bridge is used to measure a resistance.

This type of electrical circuit has 2 legs in which the current splits. Each path is composed of two resistors in series. The Wheatstone bridge is shown in figure 2.

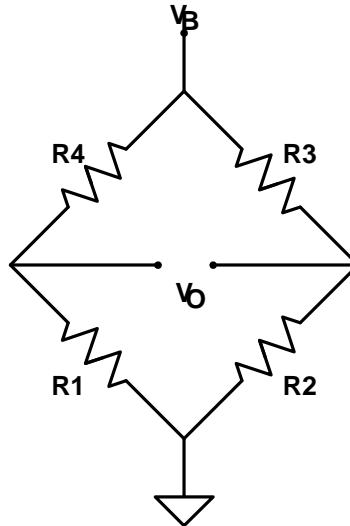

Figure 2. The wheatstone bridge

A bridge measures resistance indirectly by comparison with a similar resistance. The two principle ways of operating a bridge are as a null detector or as a device that reads a difference directly as voltage.

### 2.3. Null detector

When  $V_O$  is null, the bridge is said to be balanced. It is easy to see that the bridge is balanced when the following equation is verified.

$$\frac{R4}{R1} = \frac{R3}{R2} \tag{2}$$

This useful property of Wheatstone bridge is used to measure unknown resistance. Indeed if  $R1$  is unknown, its value can be found by adjusting  $R4$  until null is achieved. Null measurements are principally used in feedback systems.

### 2.4. Wheatstone bridge with constant voltage drive

For the majority of sensor application employing bridges, the deviation of one or more resistors in a bridge from an initial value is measured as an indication of the magnitude in the measured variable. In this case the output voltage change is an indication of the resistance change.

The sensor can have one active resistive element, two or four elements. Depending of the sensor used, several types of configuration exist for Wheatstone bridge.

#### 2.4.1. One active element

The corresponding circuit is shown in figure (A). All the resistances are nominally equal but one of them (the sensor) is variable by an amount  $\Delta R$ . It is not difficult to show that the output  $V_O$  is not linear with  $\Delta R$  as shown in equation 3.

$$V_O = \frac{V_B}{4} \cdot \frac{\Delta R}{R + \frac{\Delta R}{2}} \tag{3}$$

The non linearity values depend of the change in resistance. This change in resistance divided by 2 gives approximately this linearity error.

In some applications the bridge non linearity may not be acceptable so but there are various methods to linearize bridges.

### 2.4.2. Two actives element

Depending of the sensor working, two differents circuits can be used as illustrated in figure (B) and (C).

The voltage output are respectively given by equation 4 and equation 5.

$$V_O = \frac{V_B}{2} \cdot \frac{\Delta R}{R + \frac{\Delta R}{2}} \tag{4}$$

$$V_O = \frac{V_B}{2} \cdot \frac{\Delta R}{R} \tag{5}$$

There is a linearity error in the first case which is the same as in the single active element but the gain has doubled. The second case is more interesting as no linearity error is provided by the circuit.

### 2.4.3. Four active elements

The circuit with the four active element is shown in figure (D).

The all-element varying bridge produces the most signal for a given resistance change and is inherently linear. It is important to notice that the output is not just a linear function of  $\Delta R$ ; it is a linear function of  $\Delta R/R$  as stated in equation 6.

$$V_O = V_B \cdot \frac{\Delta R}{R} \tag{6}$$

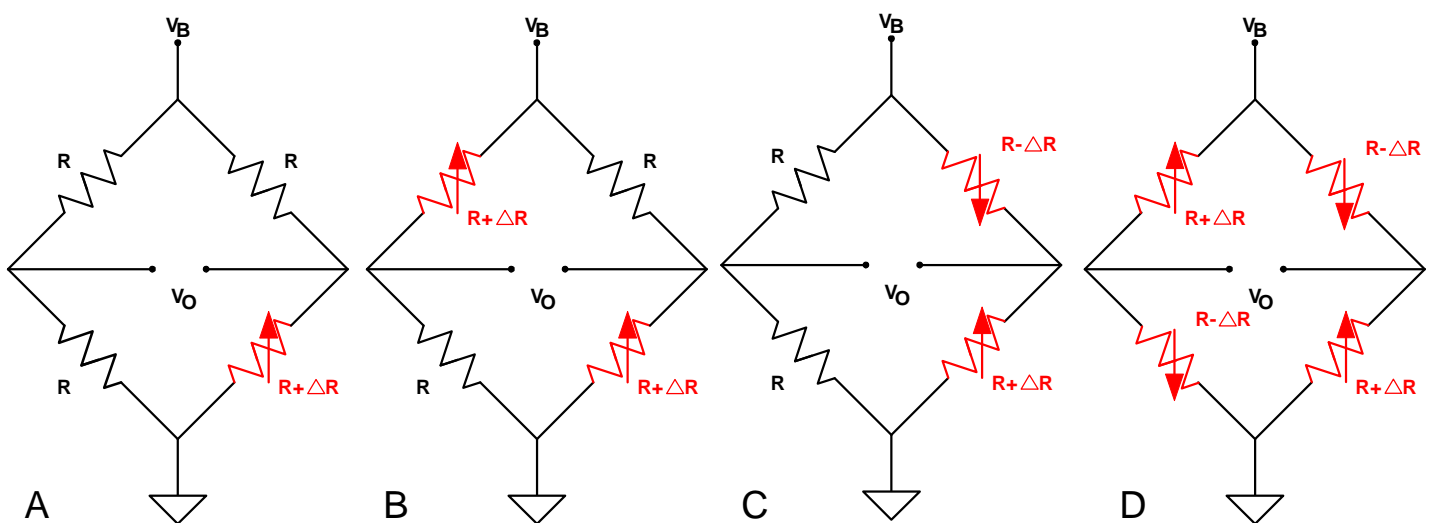

Figure 3. Constant voltage drive bridge configurations

## 3. Signal amplification

Most often, the differential output voltage of the sensor is too low to be exploited directly. For example, it is common to obtain 10mV full scale for a pressure sensor. To drive an ADC converter the signal must be amplified first. The benefit is to increase the signal to noise ratio and so to gain in resolution..

An instrumentation amplifier is a type of differential amplifier that has been specifically designed to obtain good characteristics in measurement applications. These characteristics include very low DC offset, low drift, low noise, very high open-loop gain, very high common-mode rejection ratio and very high input impedance. They are used where great accuracy and stability of the circuit both short and long-term are required.

The most commonly used instrumentation amplifier circuit is shown in the figure 4.

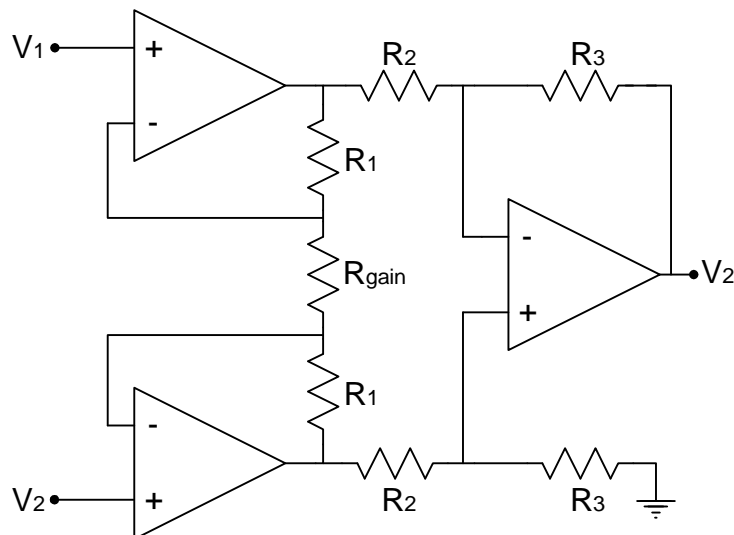

Figure 4. Instrumentation amplifier

The gain of the circuit is given by the following equation.

$$\frac{V_{out}}{V_2 - V_1} = \left(1 + \frac{2R_1}{R_{gain}}\right) \cdot \frac{R_3}{R_2} \quad (7)$$

## 4. Bridge connection to the ADC

The output voltage of any bridge is directly proportional to its supply voltage. Therefore, the circuit must either hold the supply voltage constant to the same accuracy as the desired measurement, or it must compensate for changes in the supply voltage. The simplest way to compensate for supply-voltage change is to derivate the ADC's reference voltage from the bridge's excitation.

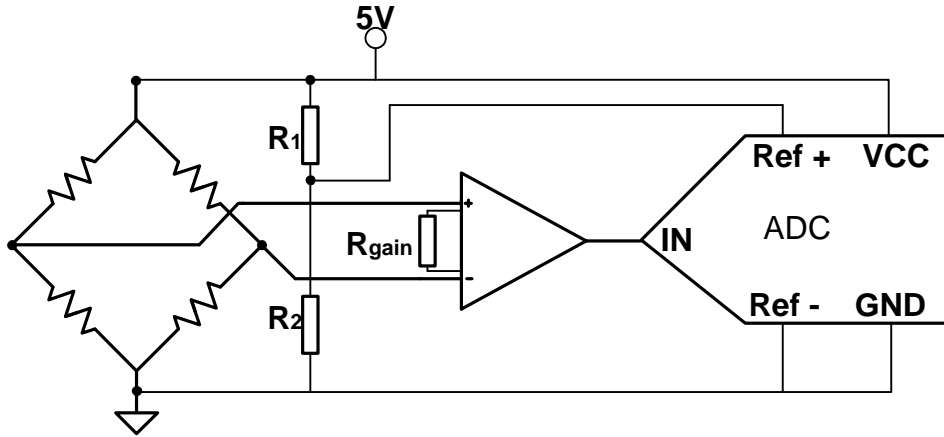

Figure 5. Bridge connection to the ADC

In figure 5, the ADC's reference voltage comes from voltage divider made with R<sub>1</sub> and R<sub>2</sub> placed in parallel with the bridge. This cause changes in supply voltage to be rejected because the reference voltage is proportional to the bridge supply.

## The working principle of pressure sensor

### 1. Introduction

Pressure sensors include all sensors, transducers and elements that produce an electrical signal proportional to pressure or changes in pressure. Pressure sensors are devices that read changes in pressure, and relay this data to recorders or switches.

Pressure sensors have a wide variety of applications. For example, they are used in medical to measure blood pressure, in automotive to monitor the tire pressure, in consumer applications for barometer or altimeter and in various industrial purposes.

Different kind of pressure sensors

There are numerous technologies by which pressure transducers and sensors function. Each sensor technology will have its strength and weakness. Depending of the application, the kind of measure to be done (absolute, differential, gauge), the kind of fluid to be measured (liquid, gas, viscosity), the range (low or high pressure), the frequency (low or high), an adequate sensor had to be chosen.

Some of the most widely used technologies include piston technology, mechanical deflection, strain gauge, semiconductor piezoresistive, piezoelectric (including dynamic and quasistatic measurement), microelectromechanical systems (MEMS), vibrating elements (silicon resonance, for example), and variable capacitance.

### 2. Strain gauge pressure sensor

As we can see from Figure 1, a strain gauge is a long length of conductor arranged in a zigzag pattern on a membrane.

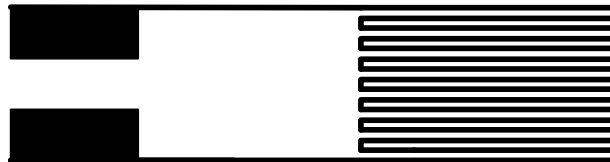

Figure 1. Strain gauge

It is used to measure deformation of an object. A pressure transducer contains a diaphragm which is deformed by the pressure which can be measured by a strain gauged element. The Figure 2 presents the functional diagram and the

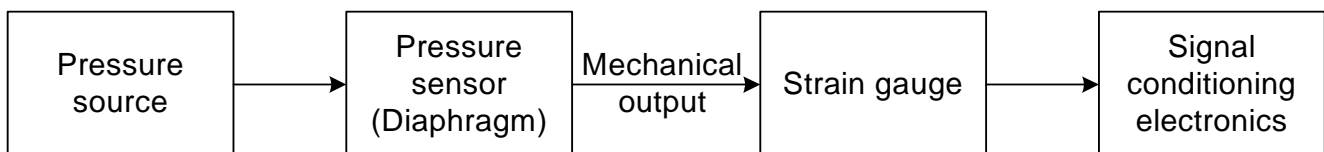

Figure 2. Functional diagram

**ADVANCED COMMUNICATIONS & SENSING** Application note

Strain gauges are mounted in the same direction as the strain. When it is stretched, it naturally becomes longer and thinner and its resistance increases. On the contrary, when it is compressed, its resistance decreases. The Figure 3 below shows a diaphragm fitted with four gauges.

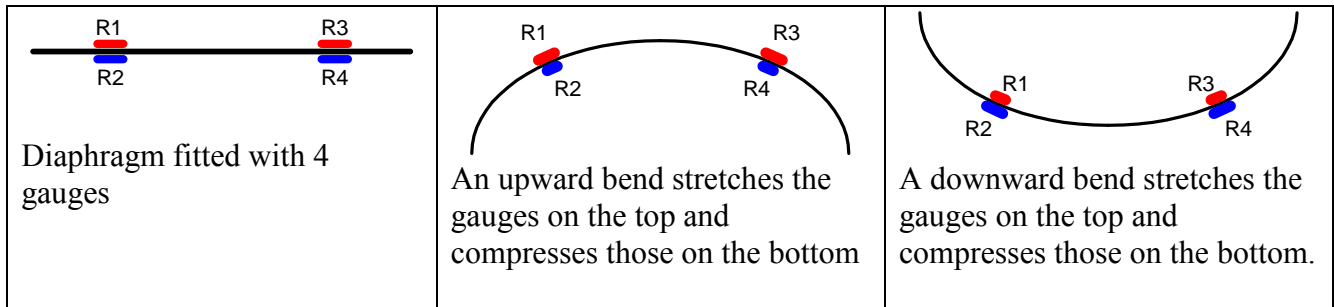

Figure 3. Strain gauge work principle

It is then efficient to mounted fours strain gages to form a full Wheatstone bridge. As seen in a previous chapter a Wheatstone bridge is appropriated to measure the resistance change with a good sensibility and optimal linearity when all the element varying.

## Measuring pressure with SX8725

### 1. Introduction

This chapter is intended to demonstrate the capabilities of the SX8725 to measure pressure signal from the Freescale MPX2202AP sensor.

The aim is to build an application to measure pressure between 1000hPa to 2000hPa with a resolution better than 5Pa. The number of sample per second should be at least 100 samples per second (100SPS).

This requirements determine the settings of the SX8725 for the pressure measuring application. Therefore, sensor signal amplification, sampling frequency and all the parameters determining the application are explained in section 4. A sum up of all registers configuration is done on section 5.

Previously, the working principles of SX8725 are clear up in section 2. It is an important part of the document as it describes the ZoomingADC™ working. Numerous examples are taken to make the understanding easier. These examples are linked to the final application.

The pressure sensor is introduced in section 3. Characteristics and part of the datasheet are shown.

Last part of the document describes the evaluation kit setting for the application in section 6.

Real evaluation of the sensor is done in last section.

#### 1.1. SX8725 features

The ZoomingADC™ is an inovative technology which permits to connects most types of miniature sensors directly to the chip. The analog adaptation circuit is therefore reduce to minimun allowing to reduce cost and space on the board.

The ZoomingADC™ has a multiplexer to select the input channel. It can be selected in pairs or one by one. Its digital outputs are used to bias or reset the sensing elements.

It is possible to choose between two voltage references: the internal voltage reference  $V_{REF}$  around 1.22V and the supply voltage  $V_{BATT}$ . Internal voltage reference is stable over time and temperature and has a low level of noise, that is why it should be used to obtain best result.

It has been designed by Semtech and is present in the low power Sigma Delta ADC family. The SX8722, SX8723, SX8724 and SX8725 are data acquisition systems and have a ZoomingADC™ to amplify small signals. A various number of sensors can be connected to the chip depending of the version. The main differences between theses chips are highlighted in the table below.

	SX8722	SX8723	SX8724	SX8725
Resolution	16	16	16	16
Programmable gain	1/12 to 1000	1/12 to 1000	1/12 to 1000	1/12 to 1000
Sensor offset compensation	up to 15 times full scale of input signal	up to 15 times full scale of input signal	up to 15 times full scale of input signal	up to 15 times full scale of input signal
Reference	2 differential inputs	VDD, internal, 1 single ended input	VDD, internal, 1 single ended input	VDD, internal, 1 single ended input
Digital Outputs	2 alarm pins with ON & OFF thresholds	2	4	2

## ADVANCED COMMUNICATIONS & SENSING

## Application note

	SX8722	SX8723	SX8724	SX8725
Number of differential inputs	4	2	3	1
Number of single-ended inputs	7	4	6	2
Oscillator	Internal 1.2MHz	Internal 2.0MHz	Internal 2.0MHz	Internal 2.0MHz
Serial Communication	I2C	I2C	I2C	I2C
Other Features	* Digital filtering * Calibration pin			
Package	MLPQ-44 (7x7)	MLPD-W-12 (4x4)	MLPQ-16 (4x4)	MLPD-W-12 (4x4)

The SX8725 is chosen for this application because only one differential input is needed for the pressure sensor.

The SX8725 has 4 sampling frequency from 67.5kHz to 500kHz. This frequency originates from the internal 2MHz oscillator. With low frequency it is possible to reduce power consumption by decreasing current biasing in the ADC and the programmable gain amplifier.

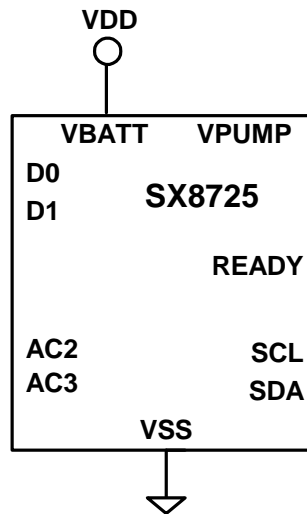

Figure 1. Input output of the SX8725

If not mentioned, the following settings are used in this application note:

- ◆ The internal Vref equals to 1.22V is chosen to be the reference of the ADC and the PGA.
- ◆  $V_{REF,ADC} = V_{REF} \cong 1.22V$
- ◆ The sampling frequency is set to 500kHz.
- ◆ The bias current of the ADC and the PGAs are set to 100%.

The following writing convention is taken:

**ADVANCED COMMUNICATIONS & SENSING** Application note

- ◆ A x-y signal is a signal with a minimum voltage of x volt and a maximum voltage of y volt refer to the ground.  
Example: A 0-100mV signal is comprised in the 0-100mV range refer to the ground.
- ◆ The medium voltage of a x-y signal is (x+y)/2.

## 2. How to use ZoomingADC™?

### 2.1. Overview

The ZoomingADC™ shown in figure 2 is a complete analog front end intended for sensing applications.

The total acquisition chain consists of an input multiplexer, 3 programmable gain amplifier (PGA) stages and an oversampled A/D converter.

The reference voltage can be selected on two different channels. The input voltage is modulated and amplified through stages 1 to 3. Fine gain programming up to 1'000 V/V is possible. Two offset compensation amplifiers allow a wide offset compensation range. The programmable gain and offset give the possibility to zoom in on a small portion of the reference voltage defined input range.

The output of the PGA stages is directly fed to the analog-to-digital converter (ADC), which converts the signal  $V_{IN,ADC}$  into digital.

When the resolution of the ADC is set to 16 bits, the simple equation 1 link  $OUT_{ADC}$  to  $V_{IN,ADC}$ .

$$OUT_{ADC} = 65535 \times \frac{V_{IN,ADC}}{V_{ref}} - 32768 \tag{1}$$

In the next section, we will see the rules to follow, the use of the different PGA through examples and at last the complete use in a pressure measure application.

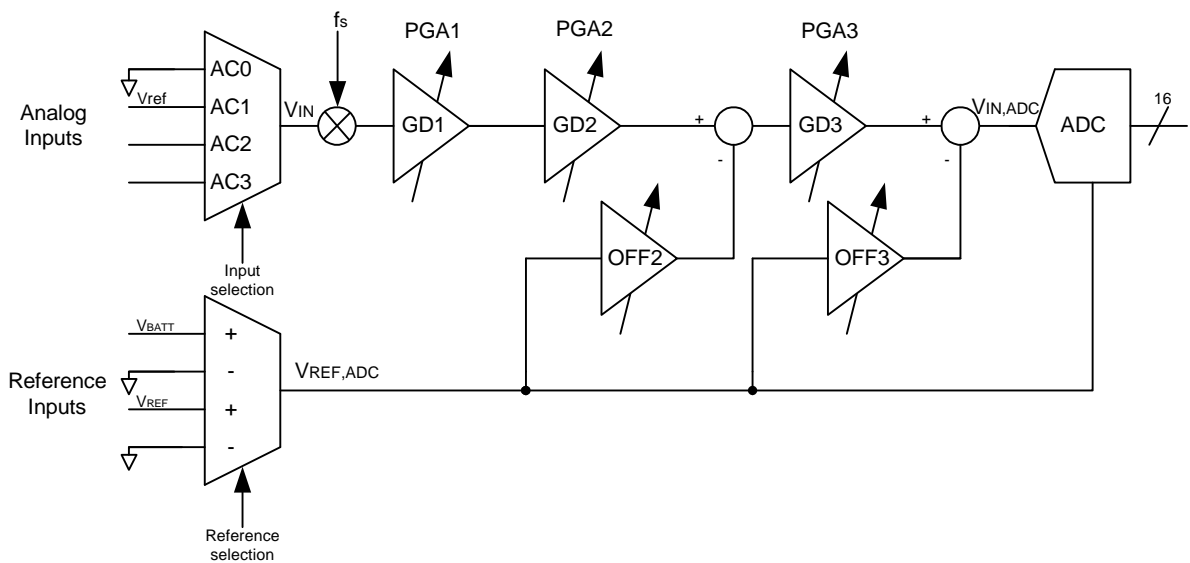

Figure 2. The ZoomingADC™ functional block

## 2.2. Gain setting rules

The gain is applied with a series of 3 PGAs to be able to obtain a high amplification. The goal is to map the input signal on the full input range of the ADC to reach the maximum of the resolution. Each PGA has its speciality depending of its position in the signal chain.

PGA1 is a coarse gain for high amplification level while PGA2 has a medium gain and offset tuning.

PGA3 has a fine gain and offset tuning. Therefore, the following recommendation have to be used to optimize the gain distribution between the three amplifiers.

This 4 rules are to be followed to obtain the best of the ZoomingADC™:

- 1 For a good linearity, a maximal gain must be applied to the last amplification stages, reducing the output amplitude of the first gain stages.
- 2 Make sure that the output range of PGA1 should be within  $\pm V_{batt}/5$  and output range of PGA2 should be within  $\pm V_{batt}/2$  otherwise part of the signal will saturate the ADC.
- 3 Keep some margin for the absolute precision of the parameters (15% if no offset cancellation and 25% if offset cancellation)
- 4 Keep some margin for temperature drift

A PGA that is not used can be by-passed, adding no noise or current requirement to the system. If only one PGA is used, it should be PGA3 that is the most versatile and has the highest linearity. Therefore the explanations below will start with PGA3.

### 2.2.1. Using PGA3

PGA3 can be set for gains between 1/12 and 127/12 with a pitch of 1/12. It is a fine gain to reach with accuracy the gain wanted. The output range of PGA3 must fit within  $\pm V_{ref}/2$ .

Offset cancellation is used to avoid amplifier saturation when dynamic of the signal is not centered to 0. Having min.-max of the signal well distributed around 0 is interesting to apply a maximal gain.

Offset is related to  $V_{ref}$ . The setting selected is multiplied with  $V_{ref}$  to obtain the corresponding offset voltage. Offset can be applied between  $-63/12 \cdot V_{ref}$  and  $63/12 \cdot V_{ref}$  with a resolution of  $1/12 \cdot V_{ref}$ .

The output of PGA3 is directly connected to the input of the ADC. Following equation link output and input of PGA3 with the gain and offset setting.

$$V_{out}(PGA_3) = V_{in}(PGA_3) \cdot PGA_3(Gain) - V_{REF} \cdot PGA_3(Offset) \quad (2)$$

(3)

Therefore offset setting can be calculated with

$$PGA_3(Offset) = \frac{(maxV_{out}(PGA_3) + minV_{out}(PGA_3)) \cdot PGA_3(Gain)}{2} \cdot \frac{1}{V_{ref}} \quad (4)$$

(5)

Example i:

*Situation* : A 0-100mV full scale signal is applied at the input of PGA3. An amplification factor of 117/12 is set up on PGA3.

What is the advantage of offset compensation ?

*Solution:*

The amplifier will saturate if no offset compensation is used. An offset compensation of  $5/12 \cdot V_{ref}$  is applied to focus the 50mV medium voltage on 0V. Using the offset compensation permits to avoid amplifier saturation.

$$PGA_3(Offset) = \frac{(100mV + 0)}{2} \cdot \frac{1}{V_{ref}} \cong 0.4 \rightarrow PGA_3(Offset) = \frac{5}{12}$$

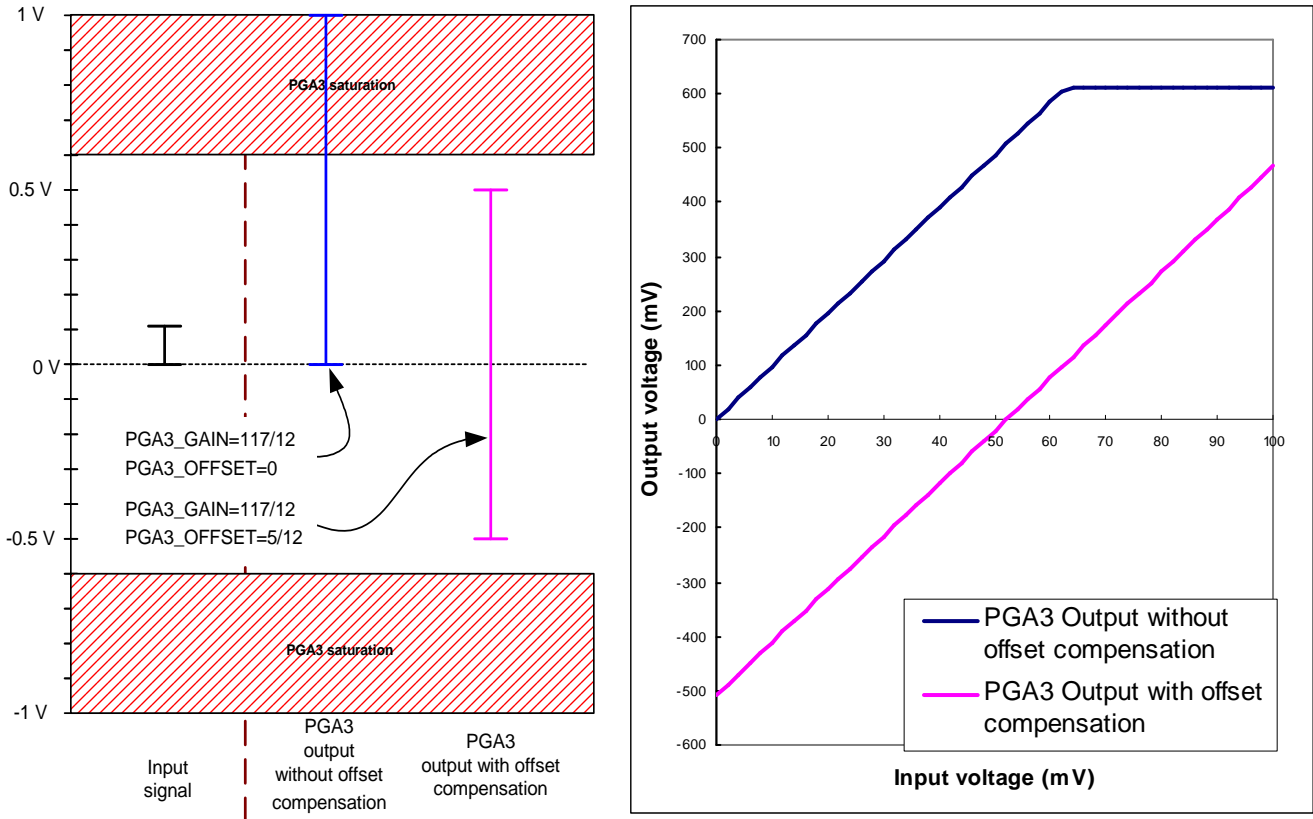

Figure 3. Offset compensation to avoid saturation

### 2.2.2. Using PGA1 and PGA2

If the gain obtained by the PGA3 is not sufficient to have a signal that covers the full input range of the ADC, one can increase it further by using PGA2 and PGA1.

The middle amplification stage PGA2 has a medium gain tuning. The gain of PGA2 can be chosen between 1, 2.5 or 10. It could be strange to apply a unity gain whether while bypassing the stage permit to reach better performance in terms of noise and power. In fact this possibility is to allow offset cancellation when no amplification is needed.

As for PGA3, stage 2 has an offset cancellation feature. The offset cancellation can be set between  $-1 \cdot V_{ref}$  to  $1 \cdot V_{ref}$  with step of  $0.2 \cdot V_{ref}$ .

PGA1 can be set if needed for a gain of  $1^1$  or 10. It is a coarse gain tuning which is useful to obtain high gain.

Remember, the output voltage of the programmable gain amplifier must not exceed  $\pm V_{batt}/5$  for PGA1 and  $\pm V_{batt}/2$  for PGA2 as stated in rule 2. Following equations show the relation between input and output voltage.

$$V_{out}(PGA_2) = V_{in}(PGA_2) \cdot PGA_2(Gain) - V_{REF} \cdot PGA_2(Offset) \quad (6)$$

1. Set PGA1 with a gain of 1 does not change the total gain. It could have an interest to obtain a high input impedance. Indeed, the input impedance is the impedance of the first stage enabled and is inversely proportional to gain. The disadvantage is noise is added to the circuit and power consumption is increased.  
Example: PGA2 is set with a gain of 10.  
By applying a gain of 1 on PGA1 instead of bypassing it, the input impedance is multiplied by 10.

$$V_{out}(PGA_1) = V_{in}(PGA_1) \cdot PGA_1 Gain \tag{7}$$

$$PGA_2(Offset) = \frac{(maxV_{out}(PGA_2) + minV_{out}(PGA_2)) \cdot PGA_2(Gain)}{2} \cdot \frac{1}{V_{ref}} \tag{8}$$

Example ii:

*Situation:* A 0-20mV signal is applied at the input of PGA2 programmed with a gain of 5.

Is it possible to best center around 0 this signal ?

*Solution:*

The absolute min.-max value of the output signal are 0-100 mV. Theses values fit within  $\pm V_{batt}/2$ . The minimum offset value (0.2.Vref) is too high to re-center the input signal, it makes no sense to offset the signal.

$$PGA_2(Offset) = \frac{(20mV + 0) \cdot 5}{2} \cdot \frac{1}{V_{ref}} \cong 0.04 \rightarrow PGA_2(Offset) = 0$$

Input signal (mV)	PGA2 output (mV)
0	0
20	100

Table 1 : PGA2 output

### 2.2.3. Distributing the gain over the 3 stages

As stated before, the goal is to map the input signal on the full input range of the ADC to reach the maximum of the resolution.

The gain distribution for the PGA can be find with the help of the flowchart given on figure 4. This flowchart gives a rough approximation of how to distribute the overall gain G between the 3 stages.

Example iii:

*Situation :* An overall gain of 48.8 have to be distributed on the amplifier stages of the ZoomingADC™.

What are the gains distribution for each stage of the Zooming ADC?

Solutions:

PGA1 should be bypassed following the flowchart. PGA2 gain is set to 5 because the overall gain is lower than 50 but superior to 20. At least the gain for the stage 3 should be around 9.76. The available gain the nearest is 117/12.

$$PGA3 \cong \frac{48.8}{5} = 9.76 \rightarrow PGA3 = \frac{117}{12}$$

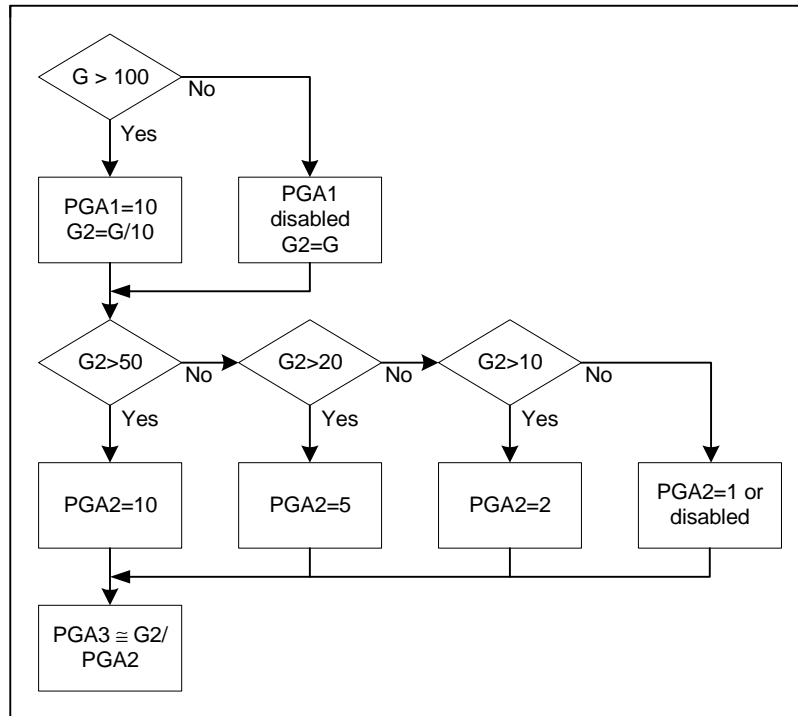

Figure 4. Gain selection flowchart

### 2.2.4. PGA settling time

When the PGA is switch ON from OFF or when the gain is changed, the PGA needs some time to settle. Indeed a feedback loop controls their common mode voltage output and it requires time to stabilize. This time depends of the ADC resolution; it is equal to the over sampling ratio in number of period of  $f_s$ . Therefore when using the PGA, a delay must be placed in software between the last access of the RegACCFg1-5 register and the triggering of the ZoomingADC™ start. Time to wait before the conversion must be superior or equal at delay given by the following formula.

$$delay = \frac{OSR}{f_s} \tag{9}$$

### 2.3. Conversion time and choice of the resolution

A complete analog-to-digital conversion sequence is made of a set of NELCONV elementary incremental conversions and a final quantization step. Each elementary conversion is made of  $(OSR+1)$  over-sampling periods. If NELCONV is choose superior or equal than 2, acquisition path offset will be removed.

The result is the mean of the elementary conversion results. A few additional clock cycles are also required to initiate and end the conversion properly.

The conversion time is calculated with the equation 10:

$$T_{CONV} = \frac{NELCONV(OSR + 1) + 1}{f_s} \tag{10}$$

**ADVANCED COMMUNICATIONS & SENSING** Application note

The figure 5 shows the conversion time vs. the resolution with a sampling frequency of 500kHz with different values for NELCONV and OSR.

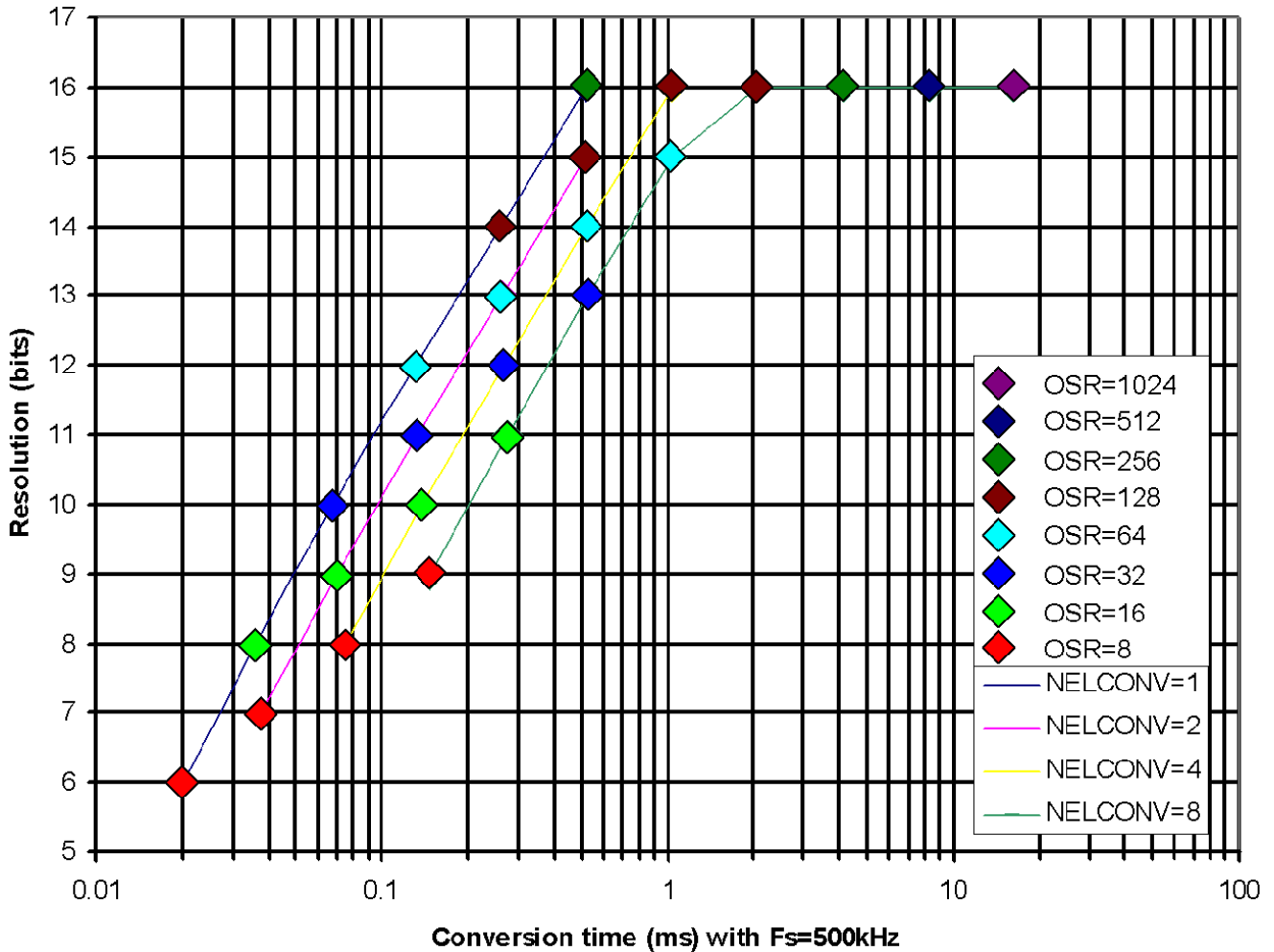

Figure 5. Resolution vs. Conversion time with different NELCONV and OSR settings

The resolution is determined by two programmable parameters: the over-sampling frequency  $f_s$  and the Number of Elementary Conversions NELCONV. Increasing NELCONV does not increase the resolution as fast as increasing OSR as shown in table 2.

OSR	NELCONV			
	1	2	4	8
8	6	7	8	9
16	8	9	10	11
32	10	11	12	13
64	12	13	14	15
128	14	15	16	16
256	16	16	16	16
512	16	16	16	16
1024	16	16	16	16

Table 2 : Resolution vs. OSR and NELCONV

Example iv:

*Situation:* A resolution of 16 bits must be obtained in less than 10 ms with a sampling frequency of 500kHz.

What are the corret settings to reach the wanted resolution ?

*Solution:*

The parameters OSR=512 and NELCONV=8 permit to obtain this result according to figure 5.

### 3. MPX2202AP sensor

MPX2202AP from Freescale is a single monolithic silicon diaphragm with a strain gauge and a thin-film resistor network integrated on-chip. It features temperature compensation over 0°C to 85°C which makes it easy to use and commonly use in medical application and robotics, barometers, altimeters...

It is given range is 0 to 2000hPa with 40mV full scale span for 10V supply voltage. The figure 6 is a plot of the output voltage versus the differential pressure.

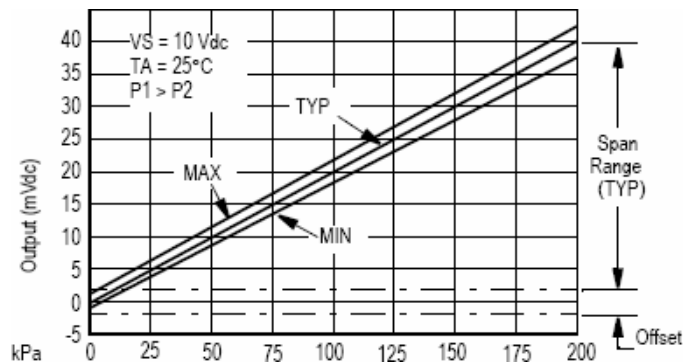

Figure 6. MPX2202AP diaphragm

## 4. Measuring pressure from MPX2202AP pressure sensor

Based on the examples described in the previous section, the sensor measuring application is designed.

### 4.1. Connection to the sensor

Output voltage of the sensor is intrinsically differential then it is advantageous to use the differential input. An output of the GPIO can be used to bias sensor. The digital pins are able to deliver a driving current up to 8 mA. The connections to the sensor are then straightforward as shown in figure 7.

AC2 is the negative input while AC3 is positive.

The differential input voltage  $V_{IN}$  is then equals to:

$$V_{IN} = V_{INP} - V_{INN} = AC_3 - AC_2 \tag{11}$$

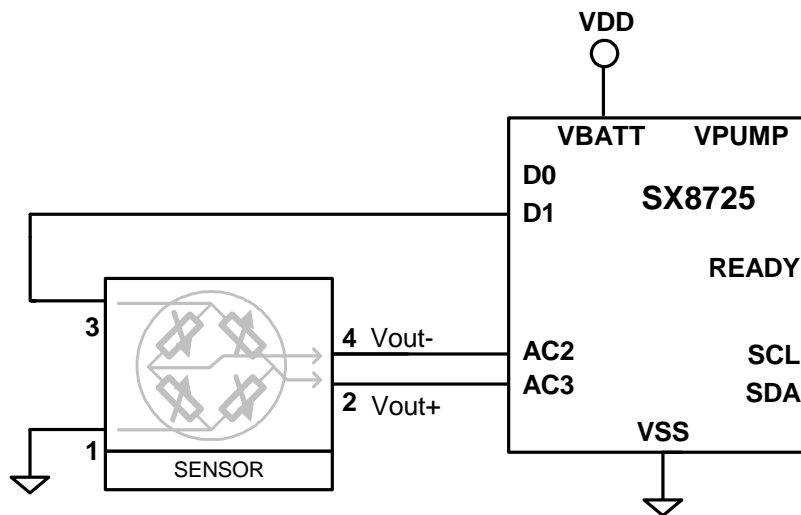

Figure 7. Sensor connection to the SX8725

### 4.2. Calculating the overall gain

The pressure sensor has a ratiometric comportment: biased under 5V the span is 20mV. If the internal reference  $V_{ref}$  is used to be the reference voltage of the ADC, the gain to applied is calculated with the following formula according to rule n° 3 seen previously.

$$Gain = \frac{SensorSpan}{V_{ref}} \cdot \frac{1}{0.75} \tag{12}$$

The sensor output span will be 10mV in our application when measuring pressure from 1000hPa to 2000hPa.

According to the SX8725 datasheet,  $V_{ref}$  is around 1.22V. Therefore, the gain to applied to obtain the full resolution is 97.6.

### 4.3. Distributing the gain

This gain of 97.6 has to be distributed over the 3 amplification stages. By using the flowchart on figure 4 the following result are found :

**ADVANCED COMMUNICATIONS & SENSING** Application note

PGA1 is bypassed.

PGA2 is set with a gain of 10.

PGA3 is set with a gain around 97.6/10. The available closest setting is 117/12=9.75.

#### 4.4. Offset calculation

##### 4.4.1. PGA2 setting

The output signal 10-20mV from the sensor is amplified with stage 2. After the amplification of 10, output voltage of PGA2 is 100-200mV. The medium voltage is then 150mV.

An offset should be subtracted to the signal to recenter it. After the offset block, the medium voltage should be the closest to 0 V. The ideal value of 150mV can't be set exactly. The best coefficient is 0.2 (xVref) which makes an offset voltage of 244mV. The medium voltage at the output of stage 2 is -94mV.

##### 4.4.2. PGA3 setting

The block 2 output is amplified by stage 3.

The medium theoretical voltage at the output of the amplifier 3 is -916.5 mV. A negative offset should be subtracted to make the medium voltage closest to 0 V. The best coefficient of -0.75 (xVref) makes an offset voltage of -915mV.

##### 4.4.3. PGA setting

The table 3 sum up the configuration used for the ZoomingADC™.

It is necessary to check that amplifier output do not exceed the limits stated in rule 2. The results of this checking is shown in table 4.

Gain		48.8
PGA1		Disabled
PGA2	Gain	10
	Offset	0.2
PGA3	Gain	117/12
	Offset	-9/12

Table 3 : PGAs setting

	Sensor output (mV)	PGA2 output (mV)	PGA2 output max (mV)	Check	PGA3 output (mV)	PGA3 output max (mV)	Check
min	10	0	> -610 mV ?	OK	-508.33	> -610 mV ?	OK
max	20	100	< 610mV ?	OK	466.67	< 610mV ?	OK

Table 4 : PGA output stage voltage

#### 4.5. Resolution setting and conversion time

The system must have a resolution of 5Pa on a total range of 2000hPa. The minimum resolution is then:

$$Resolution_{min} = \frac{2000 \times 10^2}{5} = 40000$$

That means the ADC resolution must be 16 bits (65536 output codes > 40000). As stated in the requirements, 100 samples per second have to be processed by the ADC.

The example iv with figure 5 explain that parameters OSR=512 and NELCONV=8 is a good configuration which respect the time constraint with this 16 bits resolution.

Time of the conversion is calculated below.

$$T_{CONV} = \frac{8 \cdot (512 + 1) + 1}{500 \cdot 10^3} = 8.21ms$$

## 5. SX8725 configuration

Registers are configured in this section according to the setting calculated previously.

### 5.1. RegACCFg0 register

The RegACCFg0 register control the number of elementary conversion (NELCONV) and the oversampling ratio (OSR). NELCONV and OSR are not directly selected on register RegACCFg0. The relations between NELCONV and SET\_NELC hence OSR and SET\_OSR are shown in equation 13 and equation 14.

$$NELCONV = 2^{SETNELC} \tag{13}$$

$$OSR = 2^{3+SETOSR} \tag{14}$$

The ADC is configured in continuous mode to acquire regularly the pressure.

RegACCFg0 (0x52)	1	1	1	1	1	0	1	0
(rw) START Starts an ADC conversion	←							
(rw) SET_NELC[1:0] Sets the number of elementary conversions NELCONV=8	←		←		←			
(rw) SET_OSR[2:0] Sets the ADC over-sampling rate OSR=512	←			←			←	
(rw) CONT Sets continuous ADC conversion mode	←						←	
unused	←							

Table 5 : RegACCFg0 settings

**ADVANCED COMMUNICATIONS & SENSING** Application note

### 5.2. RegACCFg1 register

Activation of PGA and ADC are done in RegACCFg1 register. Part of this register allows decreasing of the power consumption of the chip by reducing the current in ADC and PGA blocks when it doesn't work at full speed. This function is not used in this application. Setting is described in table 6.

RegACCFg1 (0x53)	1	1	1	1	1	1	0	1
(rw) IB_AMP_ADC[1:0] Bias current selection for the ADC 100% nominal current	←		←		←		←	
(rw) IB_AMP_PGA[1:0] Bias current selection for the PGA 100% nominal current	←		←		←		←	
(rw) ENABLE[3:0] ADC and PGA stage enables	←		←		←		←	
PGA 3 enable	←		←		←		←	
PGA 2 enable	←		←		←		←	
PGA 1 disable	←		←		←		←	
ADC enable	←		←		←		←	

Table 6 : RegACCFg1 setting

### 5.3. RegACCFg2 register

Sampling frequency is selected in RegACCFg2 register. Gain and Offset are also set in this register according to table 7.

RegACCFg2 (0x54)	1	1	1	1	1	0	0	1
(rw) FIN[1:0] ADC Sampling Frequency selection Fs=500kHz	←		←		←		←	
(rw) PGA2_GAIN[1:0] PGA2 gain selection PGA2=10	←		←		←		←	
(rw) PGA2_OFFSET[3:0] PGA2 offset selection PGA2=-0.2	←		←		←		←	

Table 7 : RegACCFg2 settings

### 5.4. RegACCFg3 register

PGA1 and PGA3 gain selection are made in RegACCFg3. Gain for PGA1 is set to 1 but anyway it is disabled.

RegACCFg3 (0x55)	0	1	1	1	0	1	0	1
(rw) PGA1 gain selection PGA1=1								
(rw) PGA3 gain selection PGA3=117/12 117=(1110101) <sub>2</sub>								

Table 8 : RegACCFg3 setting

### 5.5. RegACCFg4 register

RegACCFg4 sets the gain and offset for PGA3. Description of this register is made in table 9.

RegACCFg4 (0x56)	-	1	0	0	1	0	0	1
PGA3_OFFSET[6:0] (rw) PGA3 offset selection PGA3=-9/12 -9=(1001001) <sub>2</sub>								

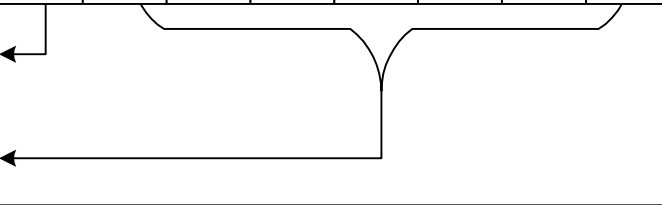
Table 9 : RegACCFg4 setting

### 5.6. RegACCFg5 register

Selection of analog and reference input selection are made through RegACCFg5 register. Content of RegACCFg5 register is described in table 10.

RegACCFg5 (0x57) = 0x03	0	0	0	0	0	0	1	1
(r) BUSY Set to 1 if a conversion is running								
(w) DEF Sets all values to their defaults and start a new conversion								
(rw) AMUX[4:0] Set the mode								
Differential inputs -> 0								
Set the sign : positive polarity ->0								
Set the channel to 1 ->1								
(rw) VMUX Sets the differential reference channel : VREF ->1								

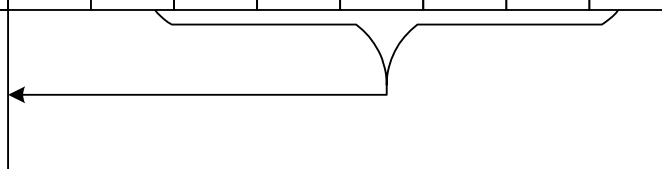
Table 10 : RegACCFg5 setting

## 6. Using the evaluation board

The SX8725 can be evaluated easily by using the XE8000EV121EVK which is configured with an SX8724. The only difference is the ADC differential input number which is 3 for the SX8724 instead of 1 for the SX8725. The setup and register will be the same if the AC2-AC3 differential input is set on the SX8724.

The evaluation kit contains an evaluation board and a software which drives it via a USB connection. The board has a large area where the sensor can be solder and interface the SX8724 to the sensor is straightforward with the connections available.

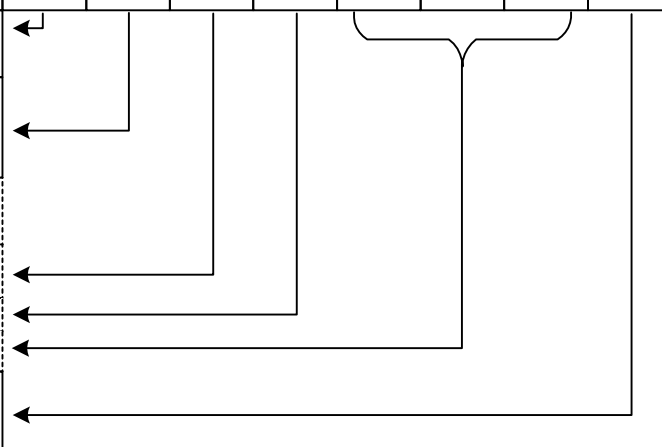
The software makes the setting of the chip easy. Two tabs “ZoomingADC™” and “General” permits the configuration of the PGA and the ADC for the first tab and the GPIO, the charge pump, the oscillator for the second one.

Registers content of SX8724 can be enter directly on the right side of the interface or by checking and selecting the parameters in the scrolling bars.

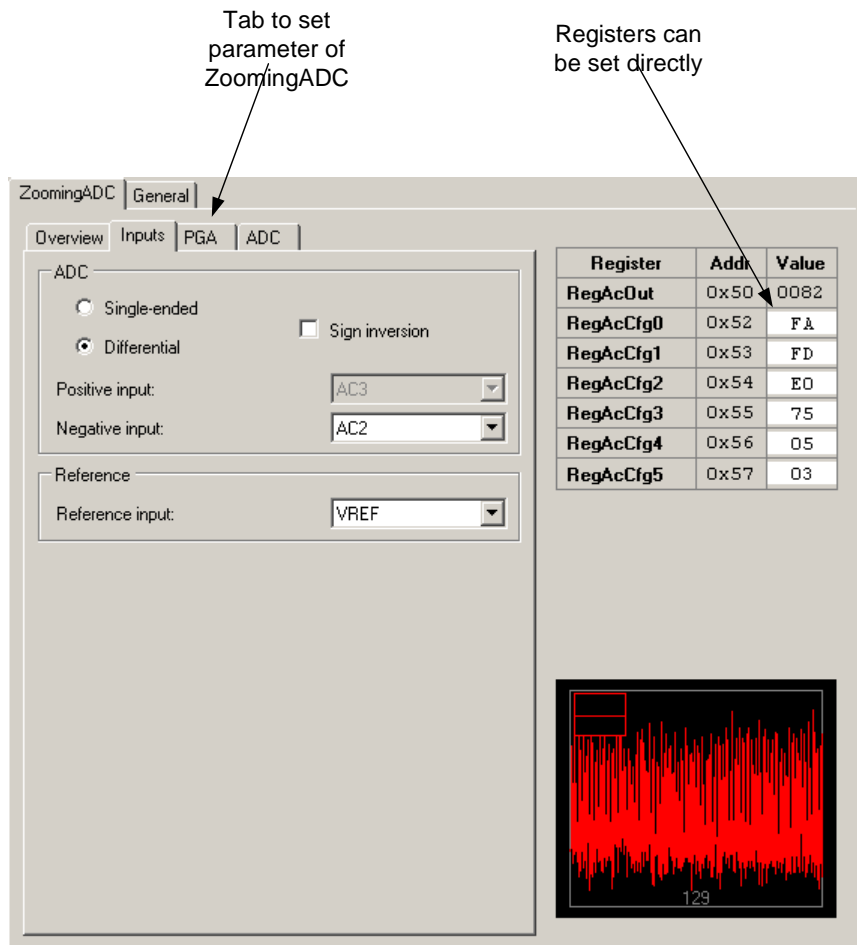

Figure 8. Graphical interface view of SX87xx evaluation software

## ADVANCED COMMUNICATIONS & SENSING Application note

Each parameter can be set on the different tab (“Inputs”, “PGA”, “ADC”) and the final result is shown on the “Overview” tab as shown in figure 8.

General configuration is sum up in figure 9.

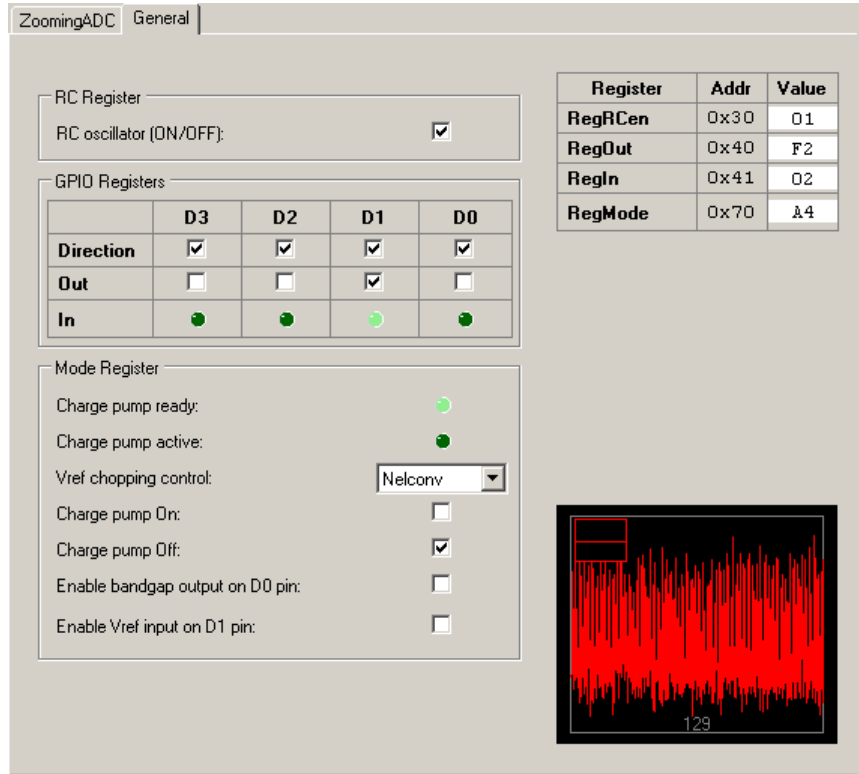

Figure 9. General tab display

## 7. Calibration procedure

To improve the accuracy, each sensor must be calibrated to compensate for part-to-part variations. In order to perform a two point calibration, the offset and the gain of the sensor must be calculated (the assumption of linearity is done on the sensor).

### 7.1. Measure

The pressure sensor is connected to a pressure regulator in order to perform measurements. The figure below describes the pneumatic connection.

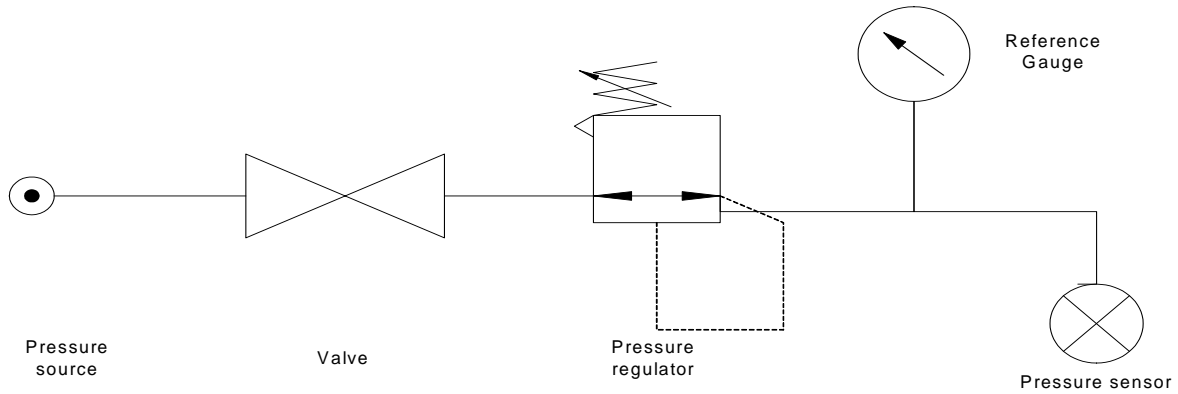

Figure 10. Pneumatic schematic

A set of measures is done with different pressure applied to the sensor between 1000 hPa and 2000 hPa. The ADC output code is recorded for each pressure applied. The table 11 is then constituted.

Pressure (hPa)	ADC Output code	Pressure (hPa)	ADC Output code	Pressure (hPa)	ADC Output code	Pressure (hPa)	ADC Output code
999.4	-27828	1270.4	-12645	1543.9	2679	1786.8	16236
1016.3	-26874	1292.3	-11364	1567.1	3965	1810.6	17608
1049.5	-24996	1320.5	-9809	1590.3	5258	1833.7	18873
1065.1	-24132	1345.5	-8409	1611.5	6431	1856.9	20205
1084.5	-23026	1376.2	-6674	1632.8	7654	1880.0	21496
1105.2	-21858	1401.2	-5278	1658.5	9080	1903.2	22768
1129.6	-20503	1426.3	-3889	1682.3	10418	1927.6	24134
1154.6	-19103	1458.8	-2092	1706.7	11761	1939.5	24794
1182.8	-17482	1495.1	-35	1727.3	12921	1969.5	26511
1212.8	-15851	1500.1	193	1746.7	14004	1995.8	27965
1241.0	-14266	1520.2	1374	1767.4	15170		

Table 11 : Pressure measures at ambient temperature

## 7.2. Calibration curve

The calibration curve give an idea of how linear is the sensor. If the pressure is applied in the linear response range of the sensor, the plot should be a straight line. Unfortunately, the system is not perfect and a best-fit straight line should be computed. The best-fit straight line can be found by linear regression analysis. The least squares criterion is a good method which consist to minimize the sum of squared errors.

Deviations from the best-fit line give a good indication about the precision of the result. It provides an empirical relationship which depend of the measurement condition for example the temperature. The R-Squared value is often computed by statistical tools. It is a statistic that will give some information about the goodness of fit of a model. If the R-Squared value is 1.0, then the regression line perfectly fits the data. If R-Squared is null there is no linear relationship between the variable.

In our application it is a statistical term saying how good the ADC output code is at predicting the pressure. The value of R-Squared of 1 says that the linear model is a good model for the sensor.

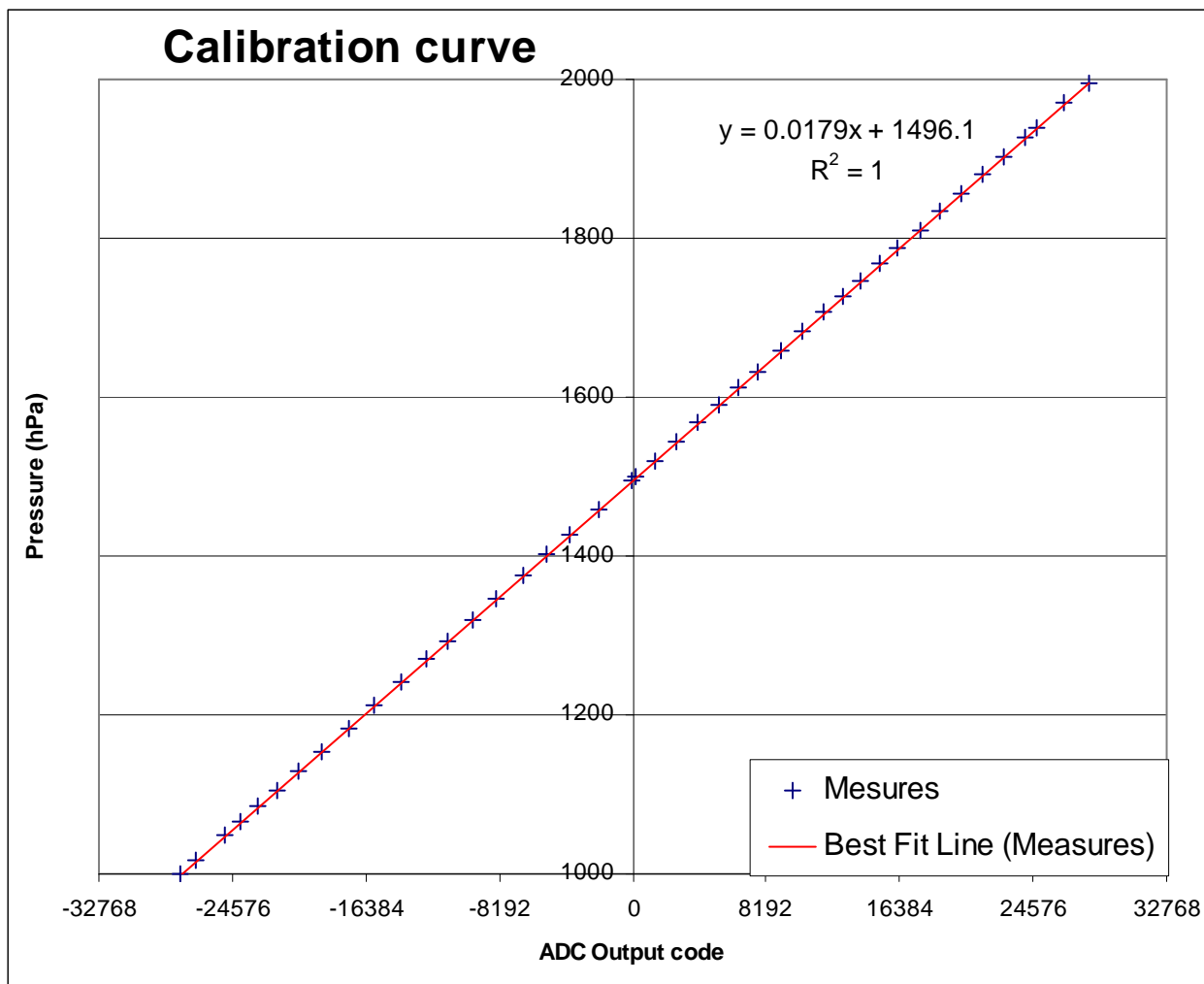

Figure 11. Measures and Best Fit Straight Line

The Best Fit Line equation is :

$$Pressure(hPa) = 0.0179 \times ADCOutputcode + 1496.1$$

It could be coded on a microcontroller interfaced to the ADC to display the pressure measured on a LCD.

© Semtech 2007

All rights reserved. Reproduction in whole or in part is prohibited without the prior written consent of the copyright owner. The information presented in this document does not form part of any quotation or contract, is believed to be accurate and reliable and may be changed without notice. No liability will be accepted by the publisher for any consequence of its use. Publication thereof does not convey nor imply any license under patent or other industrial or intellectual property rights. Semtech assumes no responsibility or liability whatsoever for any failure or unexpected operation resulting from misuse, neglect improper installation, repair or improper handling or unusual physical or electrical stress including, but not limited to, exposure to parameters beyond the specified maximum ratings or operation outside the specified range.

SEMTECH PRODUCTS ARE NOT DESIGNED, INTENDED, AUTHORIZED OR WARRANTED TO BE SUITABLE FOR USE IN LIFE-SUPPORT APPLICATIONS, DEVICES OR SYSTEMS OR OTHER CRITICAL APPLICATIONS. INCLUSION OF SEMTECH PRODUCTS IN SUCH APPLICATIONS IS UNDERSTOOD TO BE UNDERTAKEN SOLELY AT THE CUSTOMER'S OWN RISK. Should a customer purchase or use Semtech products for any such unauthorized application, the customer shall indemnify and hold Semtech and its officers, employees, subsidiaries, affiliates, and distributors harmless against all claims, costs damages and attorney fees which could arise.

## Contact information

### Semtech Corporation Advanced Communications & Sensing Products

Taiwan	Tel: 886-2-2748-3380 Fax: 886-2-2748-3390	Switzerland	Tel: 41-32-729-4000 Fax: 41-32-729-4001
Korea	Tel: 82-2-527-4377 Fax: 82-2-527-4376	United Kingdom	Tel: 44-1794-527-600 Fax: 44-1794-527-601
Shanghai	Tel: 86-21-6391-0830 Fax: 86-21-6391-0831	France	Tel: 33-(0)169-28-22-00 Fax: 33-(0)169-28-12-98
Japan	Tel: 81-3-6408-0950 Fax: 81-3-6408-0951	Germany	Tel: 49-(0)8161-140-123 Fax: 49-(0)8161-140-124