

PROTECTION PRODUCTS

Secondary Transient Protection for T1/E1 Line Cards

CMOS transceiver ICs used to interface with T1 lines are exposed to harsh transient conditions caused by lightning strikes, electrostatic discharge (ESD), and transmission power line faults. The delicate structure of the CMOS semiconductor makes it particularly susceptible to damage from voltage and current surges. This susceptibility requires it to be protected by external transient suppression circuitry. The right combination of devices and topologies can provide the secondary protection you need in T1 line cards.

TRANSIENT THREATS TO T1 LINES

Voltage transients are abnormally high pulses of voltage which are much higher than the normal operating voltage of the circuit. They are generally random in nature and may occur for tens of nanoseconds to a few milliseconds. Electronic systems connecting directly to external data and I/O lines are especially susceptible. T1 line cards are no exception. Sources of transients in telecommunications lines include the natural phenomena of lightning, electrostatic discharge (ESD), and AC power faults.

Lightning

Lightning is the most common causes of transients in electronic systems, with power and telecommunications systems being the most vulnerable. Lightning is an atmospheric discharge of electricity resulting from the accumulation of static charges, usually during a thunderstorm. Inside of a thundercloud, static charges

are generated by the impact of water and ice particles and separated in strong air currents. Lightning occurs when enough charge has been separated inside the cloud to cause localized electric breakdown of the air. At any given time, there are approximately 1800 thunderstorms in progress around the world generating lightning strikes on the surface of the earth about 100 times every second. Each cloud-to-ground event generally contains 3-5 distinct strokes, but as many as twelve have been observed. Mean peak current for the first stroke is 20kA with subsequent strokes decreasing by 50% or more. While a direct lightning strike is dramatic, it is significant to note that lightning produces intense electric and magnetic fields which can couple into nearby power lines, communication lines, and circuit wiring causing catastrophic or latent damage to semiconductor equipment. The magnitude of the induced voltage varies with the distance from the strike.

Lightning impulses are generally defined by a combination wave, one for voltage and another for current. They are defined as double exponential pulses with a specified rise time and duration or decay time. For example, an 8/20µs impulse current waveform has a rise time of 8µs and a decay time of 20µs to 50% of the peak.

The complex web of telephone network communication links makes them especially susceptible to damage due to lightning-induced transients.

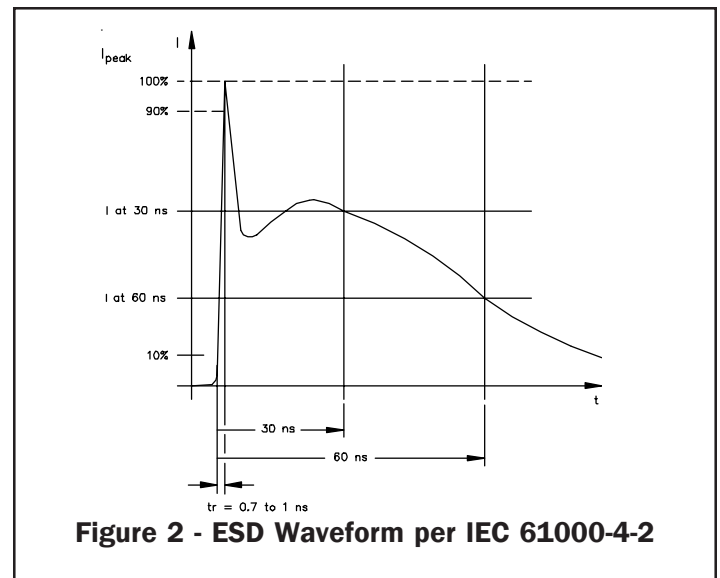
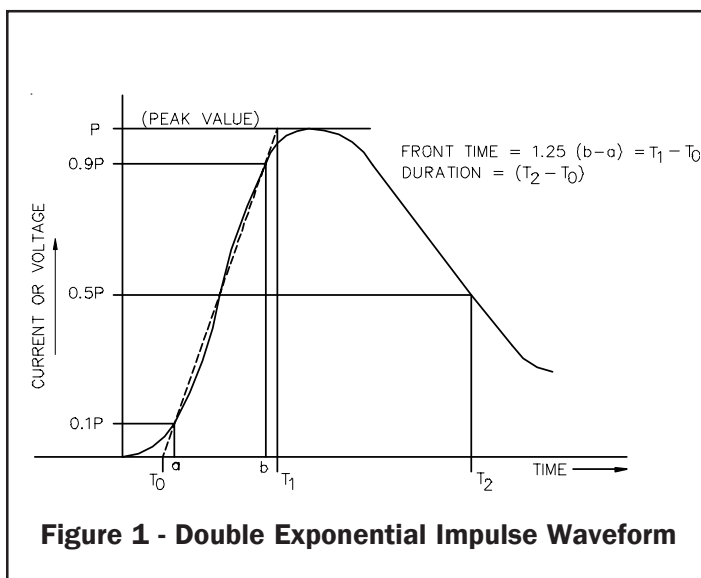

PROTECTION PRODUCTS

Electrostatic Discharge

Another cause of failure in T1 lines is electrostatic discharge (ESD). ESD is the result of a sudden and violent redistribution of electrons between two objects. The excess charge on an object usually results from the contact and separation of two non-conductive materials, causing the transfer of electrons from one material to the other, thereby building up a triboelectric charge on the surface. If the discharge path includes semiconductor based equipment, catastrophic or latent damage may occur. The amplitude of the static discharge can exceed 30kV, with currents reaching 30A or more. The rate of the discharge is extremely fast, lasting less than 1ns. The human body is one of the most common generators of ESD. It stores charge capacitively with respect to ground. The voltage potential with respect to earth ground can exceed several thousand volts. It is very common in fact for a person to develop voltages as high as 15kV. Higher voltages such as 35kV are possible, but rarer.

It is apparent that the ESD pulse contains little energy, but the extremely fast rise time and high power can be devastating to sensitive semiconductors. Failure may occur as a result of junction shorting, oxide puncture, or melting of the device metallization.

AC Power Faults

Power cross faults result from contact between the T1 line and an AC power line. This generally occurs because of the close proximity of telephone lines to power distribution lines. The magnitude of AC voltage resulting from power cross faults can exceed 600VAC. While T1 lines are more susceptible to power cross faults, electromagnetic coupling from nearby AC power lines can induce potentially harmful voltages on telecommunication lines.

TRANSIENT IMMUNITY STANDARDS

Telephone companies require network equipment to undergo transient and power fault immunity testing which simulates worst case field conditions. Transient events have been studied and characterized leading to industry-wide standards which define transient immunity requirements for electronic equipment. Transient voltage waveforms representative of induced lightning transients are often described by a double exponential impulse waveform. A double exponential surge waveform is defined as having an exponential rise to the

Surge ¹	Min Voltage ² [Vpk]	Rise/Decay Time μ s	Min Current [A]	Repetitions Each Polarity
1. L,M	600	10/1000	100	25
2. L,M	1000	10/360	100	25
3. L,M	1000	10/1000	100	25
4. L	2500	2/10	500	10
5. L	1000	10/360	25	5

Table 1 - GR-1089 First Level Lightning Surges

Surge ⁴	Min Voltage ² [Vpk]	Rise/Decay Time μ s	Min Current [A]	Repetitions Each Polarity
1. L	5000	2/10	500	1

Table 2 - GR-1089 Second Level Lightning Surges

Surge	Min Voltage ² [Vpk]	Rise/Decay Time μ s	Min Current [A]	Repetitions Each Polarity
1. M	800	2/10	100	1
2. L	1500	2/10	100	1

Table 3 - GR-1089 Intrabuilding Lightning Surges

Surge	Min Voltage ² [Vpk]	Rise/Decay Time μ s	Min Current [A]	Repetitions Each Polarity
1. M	800	10/560	100	2
2. L	1500	10/160	200	2

Table 4 - FCC Part 68 Lightning Surges

Notes:

L = Longitudinal Mode, M - Metallic Mode

Primary protectors have been removed

1 Surge 3 is optional in place of Surges 1 and 2.

2 These tests are repeated at a voltage just below the operating threshold of any secondary protectors.

3 Pulse is a double exponential waveform

4 8/20 μ s s.c. current waveform may be substituted with the inclusion of appropriate series resistance per Bellcore 1089.

PROTECTION PRODUCTS

peak and an exponential decay from that peak (Figure 1).

The pulse is specified by a rise time from 10 to 90% of the peak value and a decay to 50% of the peak value. One of the most common double exponential waveforms for induced lightning in U.S.

telecommunication systems is the 10/1000 μ s impulse waveform as defined by Bellcore **GR-1089**. In actuality, Bellcore 1089 specifies different pulse durations and stress levels depending upon equipment type.

Equipment which is designed to connect to outside lines such as wide area network (WAN) interfaces is subjected to the surge tests summarized in Tables 1 & 2. Stresses are applied in longitudinal (Line-to-Ground) and metallic (Line-to-Line) mode. Upon completion of the first level tests, the equipment must remain undamaged. The equipment may be damaged after the second level tests, but must not pose a fire or electrical safety hazard. Customer Premises Equipment (CPE) connected to inside lines is subjected to the intra-building lightning immunity tests (Table 3). Again, the equipment must remain undamaged after longitudinal and metallic surges of each polarity. Bellcore 1089 also specifies AC power cross fault immunity requirements.

FCC Part 68 registration is required of all public network equipment. FCC Part 68 specifies two lightning surges for equipment which is connected to outside lines. The first is A 100A, 10/560 μ s double exponential surge waveform applied in longitudinal mode. The second is a 200A, 10/160 μ s impulse applied in metallic configuration (Table 4).

International telecommunication standards such as **ITU K17-K20** often specify the 10/700 μ s impulse for lightning induced transients. Some of the more recently adopted standards for transient immunity are the IEC 61000-4-x series of standards set forth by the European community. **IEC 61000-4-2** defines requirements for human generated ESD transients. Test voltages range from 2kV to 15kV, with peak currents as high as 30A. The ESD waveform as defined by IEC 61000-4-2 is extremely fast with a maximum rise time of 1ns and a total duration of only 60ns (Figure 2). The total energy contained within the pulse is a few hundred microjoules. **IEC 61000-4-5** defines the lightning threat to both power and telecommunication lines. The standard specifies double exponential impulses of 1.2/50 μ s for power and 10/700 μ s for telecommunication lines to describe the threat.

TRANSIENT SUPPRESSION METHODS

The best strategy for dealing with lightning and ESD induced transient events is to divert transient current away from the T1 transceiver IC. Transient voltage suppression devices are shunt-connected across the protected line. During a transient event, transient current is shunted through the device, resulting in a lowering of the transient voltage across the protected circuit. Surge suppression devices of this type fall into two categories : clamps and crowbars. Each type has been optimized for a given transient condition.

Under normal operating conditions, the clamping device looks like a high impedance to the protected circuit. Ideally, the device appears as an open circuit, although a small amount of leakage current is present.

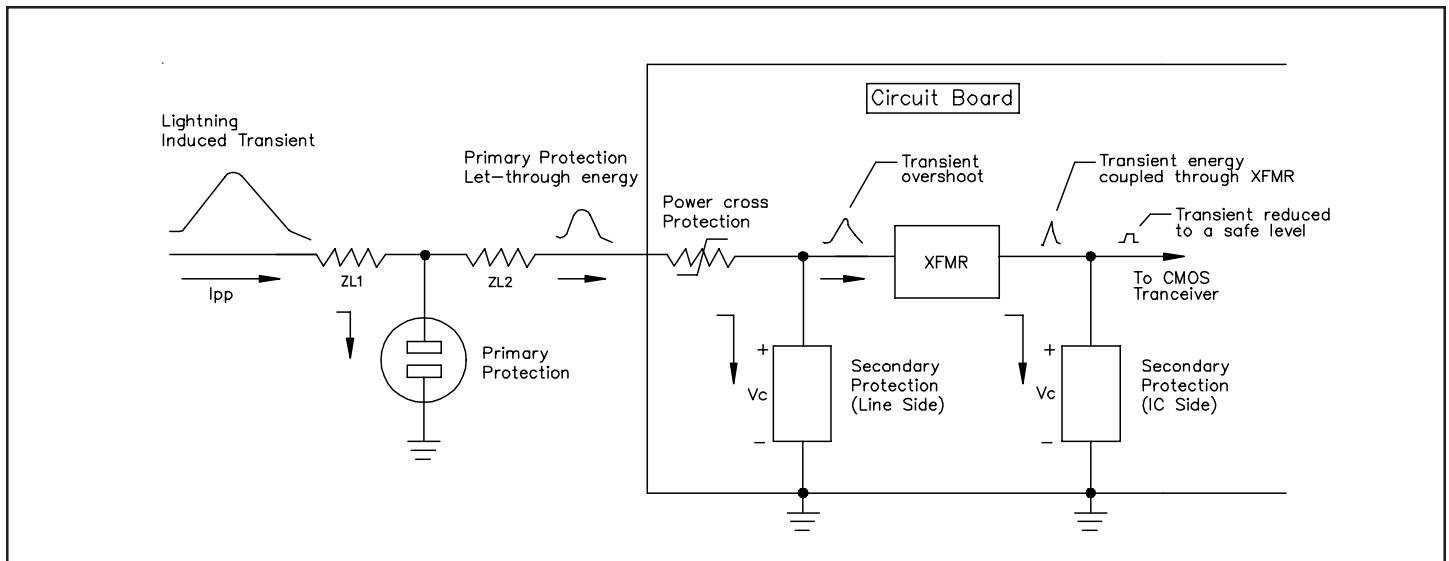

PROTECTION PRODUCTS

When a transient voltage exceeds the normal operating voltage of the line, the device becomes a low impedance path. The transient power is dissipated within the device and is limited by the maximum allowable junction temperature. Clamping devices automatically return to a high impedance state when the line voltage returns to normal levels.

A crowbar device begins to break down with a positive resistance until it reaches a break-over voltage at which point it “snaps” back to a low on-state voltage. The low on-state voltage means the device dissipates less power thus providing a higher surge current handling capability compared to a clamping device. The disadvantage is the current through the device must fall below a specified holding current in order for it to return to a non-conducting state.

PROTECTION TECHNOLOGIES

Technologies available today for parallel protection elements include metallic oxide varistors (MOVs), gas discharge arrestors (commonly known as gas tubes), and solid state devices: TVS diodes and TVS thyristors. Each type of device is designed to serve a specific application. In some cases, two or more device types may be combined to utilize the advantages of each.

Gas Tubes

Gas tubes are devices which employ an internal inert gas which ionizes and conducts during a transient event. The gas is contained in a glass or ceramic envelope with specialized electrodes placed at each end. When the voltage across the terminals reaches a certain level, the gas ionizes causing the device to spark over or “fire”. At this point, the gas tube becomes a low impedance path for the passing transient. The circuit voltage must fall below the holdover voltage of the gas tube before the device will extinguish and return to a non-conducting state. Because the internal gas requires time to ionize, gas tubes can take several microseconds to turn on. In fact, the reaction time and firing voltage are dependent upon the slope of the transient front. Gas surge arrestors have a finite life span. As the gas tube wears out, leakage currents and firing voltages increase until total failure occurs. Also, if the gas tube is over-stressed during an impulse, the hermetic seal may be breached, allowing the internal gas to escape and rendering the device useless. The high current handling capability of the gas tube allows it to be used as a primary surge protector at connections to the outside world. The high variable firing voltages

of the gas tube make it unsuitable for protecting solid state circuitry at the board level. Breakover voltages typically range from 90V - 1kV.

Metal Oxide Varistors

Metal oxide varistors (MOVs) are nonlinear devices whose resistance varies with applied voltage. MOVs are composed of a ceramic-like material usually formed into a disc shape. High transient capability is achieved by increasing the size of the disc. The MOV can be viewed as several p-n junctions in a series and parallel configuration. This gives the MOV its characteristic IV curve, similar to back-to-back zener diodes. MOVs gradually degrade with each transient event. Granular interfaces overheat and begin to short, resulting in a gradual decrease in breakdown voltage. Eventually, the MOV will fail and the device will achieve a permanent low impedance state and thus a loss of protection results. MOVs turn on in a few nanoseconds and have fairly high clamping voltages ranging from approximately 30V to as much as 1.5kV. The MOVs’ high parasitic capacitance make them unsuitable for use on digital T1 lines.

TVS Thyristors

TVS thyristors are solid state devices constructed with four alternating layers of p-type and n-type material. The resulting structure is similar to an SCR whose gate is controlled by an avalanche zener diode. TVS thyristors are crowbar devices which switch to a low on-state voltage when triggered. Because the on-state voltage is so low, the TVS thyristor is able to conduct very high surge currents. Again, the current through the device must fall below the holding current before it will restore to a non-conducting state. TVS Thyristors do not wear out nor do they exhibit the large overshoot voltage of gas tubes. Additionally, TVS thyristors are fast responding (nanoseconds) and have operating voltages starting at approximately 28V on up. The devices unique characteristics make them well suited for many telecommunications applications.

TVS Diodes

TVS diodes are solid state p-n junction devices. A large cross sectional area is employed for a TVS diode junction allowing it to conduct high transient current. By controlling such factors as junction depth, doping concentration, and substrate resistivity, the manufacturer can vary the target voltage of the device. TVS diodes are clamping devices. When the transient voltage exceeds the normal circuit operating voltage, the TVS diode becomes a low impedance path for the

PROTECTION PRODUCTS

transient current. The device returns to a high impedance state after the transient threat passes. TVS diodes will not wear out nor will there be any degradation of the electrical parameters as long as the device is operated within specified limits. A primary attribute of the TVS diode is its reaction time. Avalanche breakdown theoretically occurs in picoseconds. This is very difficult to measure however, therefore TVS

diodes are often specified as responding “almost instantaneously”. TVS diodes are available in a wide range of operating voltages. Traditional device voltages range from 5V to 440V for discrete devices. Recent innovations in TVS technology have yielded devices which operate at 2.8 and 3.3V. TVS diodes have an inherent voltage dependent capacitance. In high speed data applications, too much added line

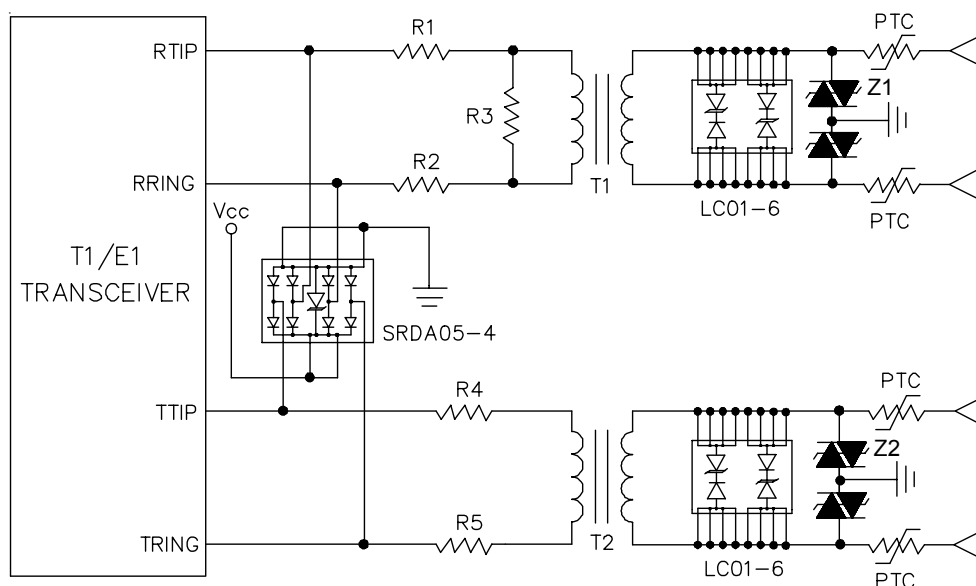

Component	Description	Part #	Source
LC01-6	6V, Bidirectional Low Capacitance TVS Diode	LC01-6	Semtech
PTC	4 - 7Ω Positive Temperature Coefficient Resistor	TR600-160	Raychem
Z1, Z2	275V TVS Thyristor		
R1, R2	470Ω, 1/4W, 1% Resistor		
R3	100Ω, 1/2W, 1% Resistor		
SRDA05-4	RailClamp™ Low Capacitance Surge Protection Diode Array	SRDA05-4	Semtech

Notes :

1. Thermal fuse resistors (ALFR-2-5.6-1, IRC, Inc.) may be substituted for PTC devices.
2. Resistors may be added to TTIP & TRING to negate the signal attenuation effect of the line feed resistors.

Figure 4 - T1 Outside Line Protection Circuit

PROTECTION PRODUCTS

capacitance can cause excessive signal degradation. Low capacitance devices are manufactured by placing a low capacitance rectifier diode in series but opposite in polarity with the TVS diode. This has the effect of adding another capacitor in series with the junction capacitor of the TVS diode. Taking advantage of the relationship for series capacitors means the resulting capacitance will be less than the smallest component in

the series. By carefully choosing the rectifier, the effective capacitance may be reduced by approximately two orders of magnitude.

The TVS diodes' fast response time and low clamping voltages make them ideal for use as board level protectors for sensitive semiconductors.

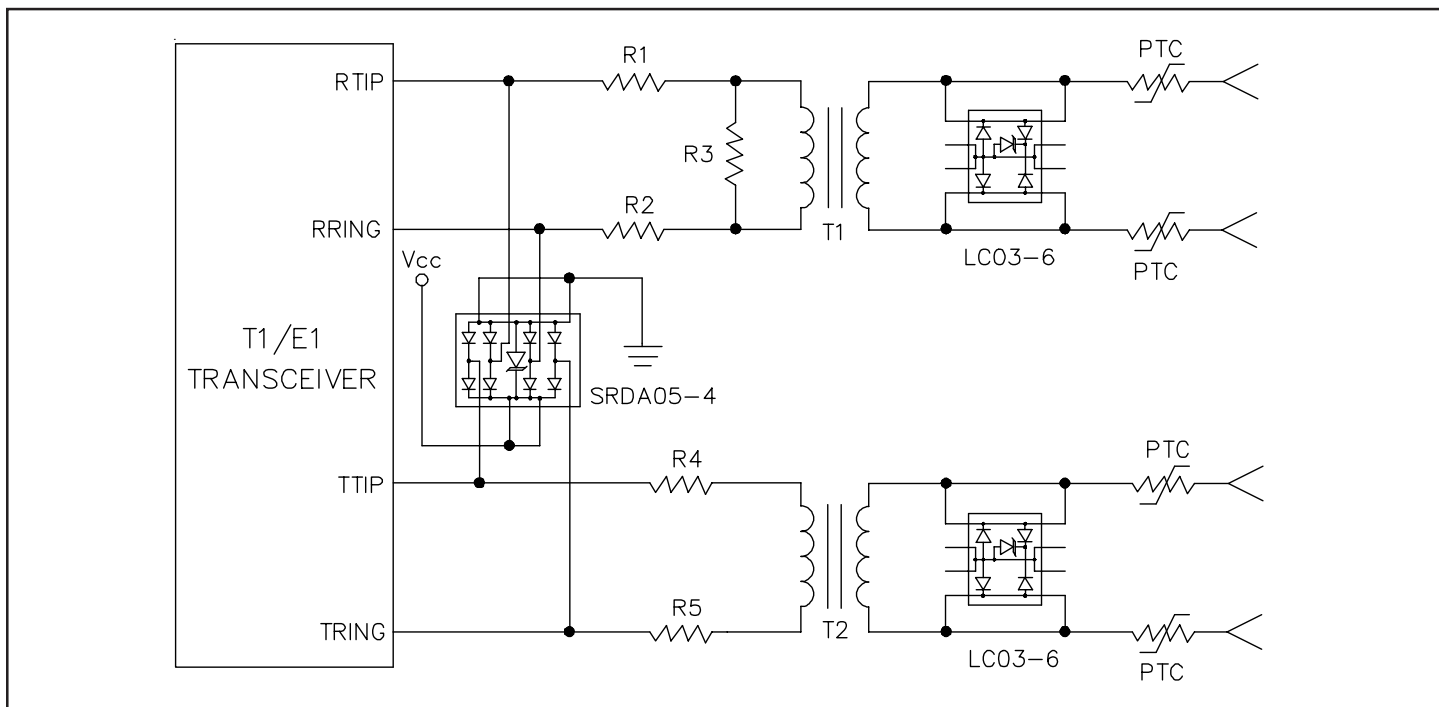

Component	Description	Part #	Source
LC03-6	6V, Bidirectional Low Capacitance TVS Diode	LC03-6	Semtech
PTC	4 - 7Ω Positive Temperature Coefficient Resistor		Raychem
R1, R2	470Ω, 1/4W, 1% Resistor		
R3	100Ω, 1/2W, 1% Resistor		
SRDA05-4	RailClamp™ Low Capacitance Surge Protection Diode Array	SRDA05-4	Semtech

Notes :

1. Surge rated fuses and resistors may be substituted for PTC devices.
2. Resistors may be added to TTIP & TRING to negate the signal attenuation effect of the line feed resistors.

Figure 5 - T1 Intra-Building Protection Circuit

PROTECTION PRODUCTS

PTC Resistors

Positive temperature coefficient (PTC) resistors are overcurrent protection devices used as series protection elements. PTC devices provide current limiting during AC power crosses in telecommunications applications. Under fault conditions, the PTC heats up and its resistance increases sharply, limiting the fault current to the protected device. After the fault condition is removed, the PTC cools and resets allowing the protected circuit to function normally. Often, the devices will exhibit increased resistance after they are reset.

PROTECTION CIRCUIT

A combination of protection devices is required to provide effective transient protection for T1 interfaces (Figure 3). For outside lines, primary protectors are installed at the network interface. However, these devices, usually spark gaps or gas tubes, will not suppress transient voltages and currents to levels safe for line card ICs. Secondary protection elements at the board level are required to suppress the let-through energy from the primary protectors as well as induced lightning and ESD transients. The secondary protection elements must be capable of dissipating high transient energy while providing minimum loading capacitance. A device with too little power handling capability will be destroyed during equipment testing while too much capacitance will cause the digital waveform to fall outside of T1 pulse template specifications. Secondary transient protection for telecommunication circuits is recommended at the power supply line and signal line interfaces. Signal line protection elements are normally required on the line side and IC side of the line transformers. Line side elements absorb the bulk of the transient energy, thus protecting the transceiver IC as well as the transformers. Chip side protection is required to protect the IC transceiver from fast transient energy which is coupled through the transformer due to winding capacitance. The type of line protection which will be required depends upon the nature of the lines it is connected to.

Outside Line (Long Haul) Protection Circuit

The complete outside line protection circuit is shown in Figure 4. Receiver equalization and transmitter line build-out components are not shown for clarity. The design will meet the common mode (Line-to-Ground) and differential mode (Line-to-Line) transient immunity

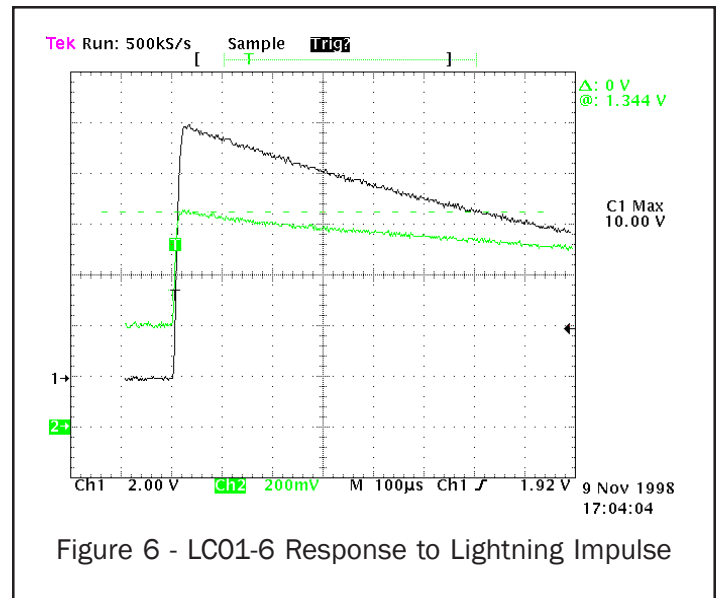

requirements and power cross requirements of Bellcore 1089, FCC Part 68, and UL 1459. The design will also meet the ESD immunity requirements of IEC 61000-4-2. The protection scheme employed is a cost effective multiple stage design aimed at protecting both the transformer and the line IC, utilizing readily available components while minimizing required board area.

The first stage of the design employs a positive temperature coefficient (PTC) resistor to provide current limiting during AC power cross faults, meeting the requirements of Bellcore 1089 and UL1459. PTC resistors are available in pre-trip resistance values of 4 - 7Ω. Under fault conditions, the resistance value of the PTC increases with temperature, limiting the fault current. The resistor also serves the purpose of limiting current to the protection elements under transient conditions. The PTC will slightly reduce the amplitude of the transmitted signal. Transceiver manufacturers often specify adding a small value resistor on the IC side of the transmit line to reduce the effect. Line feed resistors which combine a fuse with a resistive element are sometimes substituted for the PTC device. The disadvantage of these devices is they must be replaced after the fault condition is removed. Also, changes in device resistance after resetting can cause the lines to become unbalanced. For this reason, a combination of surge rated resistors and fuses are often used instead of PTC resistors.

The second stage of the design provides the main elements for meeting the lightning surge requirements

PROTECTION PRODUCTS

of Bellcore 1089 and FCC Part 68. During the metallic lightning surges, a low capacitance TVS diode (LC01-6) provides voltage and current limiting. The fast reaction time and low clamping ability of the TVS diode allow it to shunt the surge current with a maximum clamping voltage well below the transformer saturation point and the IC damage threshold (Figure 6). During longitudinal (common mode) surges a solid-state crow bar device (Z1 & Z2) is employed as the suppression element. Due to the high potential isolation rating of the line transformers, the common mode suppression element does not require a very precise clamping threshold. A device with a breakover voltage of approximately 275V rated to handle 100A ($t_p = 10 \times 1000\mu s$) is chosen (Note: Z1 and Z2 may be eliminated from the design as long as the high potential isolation rating of the T1 line transformers and power supply system are not exceeded).

The final stage of the design is implemented on the transceiver side of the transformer to protect the IC from any residual energy which is coupled through the transformer. The SRDA05-4 RailClamp® low capacitance TVS array is utilized to protect both transmit and receive line pairs as well as the power supply line. It will prevent latch up of the transceiver and clip power supply transients. A high voltage 0.47 μ F capacitor (not shown) may be used to prevent DC current flow into the transmitter transformer.

Inside Line (Short Haul) Protection Circuit

The approach to protecting intra-building metallic lines is similar to the outside line protection scheme except fewer, less expensive devices may be used. The complete inside line protection circuit is shown in Figure 5. The design will meet the intra-building lightning surge and 120V AC power cross requirements of Bellcore TR-NWT-001089. The protection elements will also provide ESD protection to IEC 61000-4-2 level 4.

Again PTC resistors are employed in the first stage of the design to provide the intra-building AC power cross protection required for customer premises equipment. A time delay fuse and a surge rated, series resistor may be substituted for the PTC resistors in some designs.

The second stage of the design provides the main elements for meeting the 100A, 2/10 μ s intra-building lightning surge requirement of Bellcore 1089. During the metallic lightning surge, the low capacitance TVS

diode is designed to shunt the surge current with a maximum clamping voltage below the transformer saturation point. An enhanced diode bridge configuration is used to provide the low capacitance feature of the TVS diode protection circuit. The bridge rectifiers are used as steering diodes to route the incoming surge safely through the TVS diode. This configuration may be implemented using discrete devices as long as components are chosen to provide the desired surge and low capacitance characteristics. Implementation with discrete components can be tricky however. First, selection of the bridge diodes is critical. The selected devices must have high forward surge capability and extremely fast switching time to be effective against ESD and lightning induced surges. Second, device layout is critical in order to reduce overshoot voltages associated with trace inductance. Finally, high component count can cause design problems when pc board space is at a premium. Alternatively, a new device (LC03-6) has been introduced which combines the surge rated diode bridge and a high power TVS diode in a single SO-8 package. The LC03-6 is specifically designed to meet the criteria necessary for protection on high speed telecommunication interfaces. Common mode surge protection will not be necessary if the line transformers are rated for a minimum isolation voltage of 1500V.

The recommended protection scheme for the transceiver side of the transformer is nearly identical to the one used on the outside line protection circuit, combining resistors, capacitors, and a TVS diode array to protect against residual transient energy. Once again the SRDA05-4 RailClamp® low capacitance diode array is used to clamp residual surges to the rail and protect the power supply line.

CONCLUSION

Telecommunication lines are constantly exposed to a harsh transient environment. CMOS IC transceivers are becoming more complex and as such, more vulnerable to transient events. Good system design requires these devices to be protected with external devices specifically designed to absorb transient energy. Several protection device types may be combined to provide optimum transient protection and meet the applicable immunity standards. The effectiveness of any line protection scheme will depend upon the specific application. As always, the completed design should undergo design verification and testing to insure compliance with appropriate specifications.

PROTECTION PRODUCTS

REFERENCES

1. Stearman, Greg, Stillings, Larry, Taylor, Roger, *“Board-Level Secondary Protection Provides Added Reliability for T1 Digital Line Cards Part 1 & 2”*, Compliance Engineering, 1993
2. Curtis, Jon, *“Meeting Bellcore’s TR-NWT-001089 Surge Requirements”*, Compliance Engineering, Summer 1993
3. Level One Corporation Application Note, *“LXT360/361 Line Protection Circuitry”*, January, 1996
4. Stringfellow, Dr Michael F. *“Lightning” Power Quality & Assurance*, Sept/Oct 1995
5. Russell, William, *“Defuse the Threat of ESD Damage,”* Electronic Design, March 6, 1995
6. Semtech Corporation Application Note #SI96-16, *“Outside Line Lightning Protection for T1/E1 CMOS IC Transceivers”*
7. Semtech Corporation Application Note #SI96-17, *“Intra-Building Lightning Protection for T1/E1 CMOS IC Transceivers”*

The original version of this article appeared as “Solve Transient-Protection Problems With Devices & Topology” in EDN magazine, April 10, 1997