

POWER MANAGEMENT

Description

The SC613 is a versatile charge pump designed for use in battery operated power supply applications. The wide input range is matched for Li-Ion battery applications. Only two 1uF ceramic bucket capacitors are required, and the inductorless implementation provides a reduced-EMI solution. Low noise mode switching circuitry and constant output current allow the use of 1uF input and output capacitors.

The SC613 charge pump regulator can be used for applications that require up to 140mA of output current with a 4.5V output. The 5.0V output version provides up to 100mA of output current. The small package size, low component count and lower overall system cost coupled with its low noise make the SC613 a superior solution compared to switch mode regulator designs.

Features

- ◆ Small size - MLP Micro 10 lead 3x3mm package
- ◆ Selectable 5.0V or 4.5V output voltage
- ◆ 140mA available with 4.5V output
- ◆ 100mA available with 5.0V output
- ◆ Short circuit protection
- ◆ Soft Start function
- ◆ Shutdown current <math><2\mu\text{A}</math>
- ◆ Selectable fixed frequencies of 262kHz and 650kHz
- ◆ Low ripple
- ◆ Regulated to $\pm 5\%$
- ◆ Ease of use

Applications

- ◆ Cellular phones
- ◆ LED photo flash for cellular phones
- ◆ LED backlighting
- ◆ PDA power supplies
- ◆ Portable electronics
- ◆ Electronic books
- ◆ Wireless web appliances

Typical Application Circuit

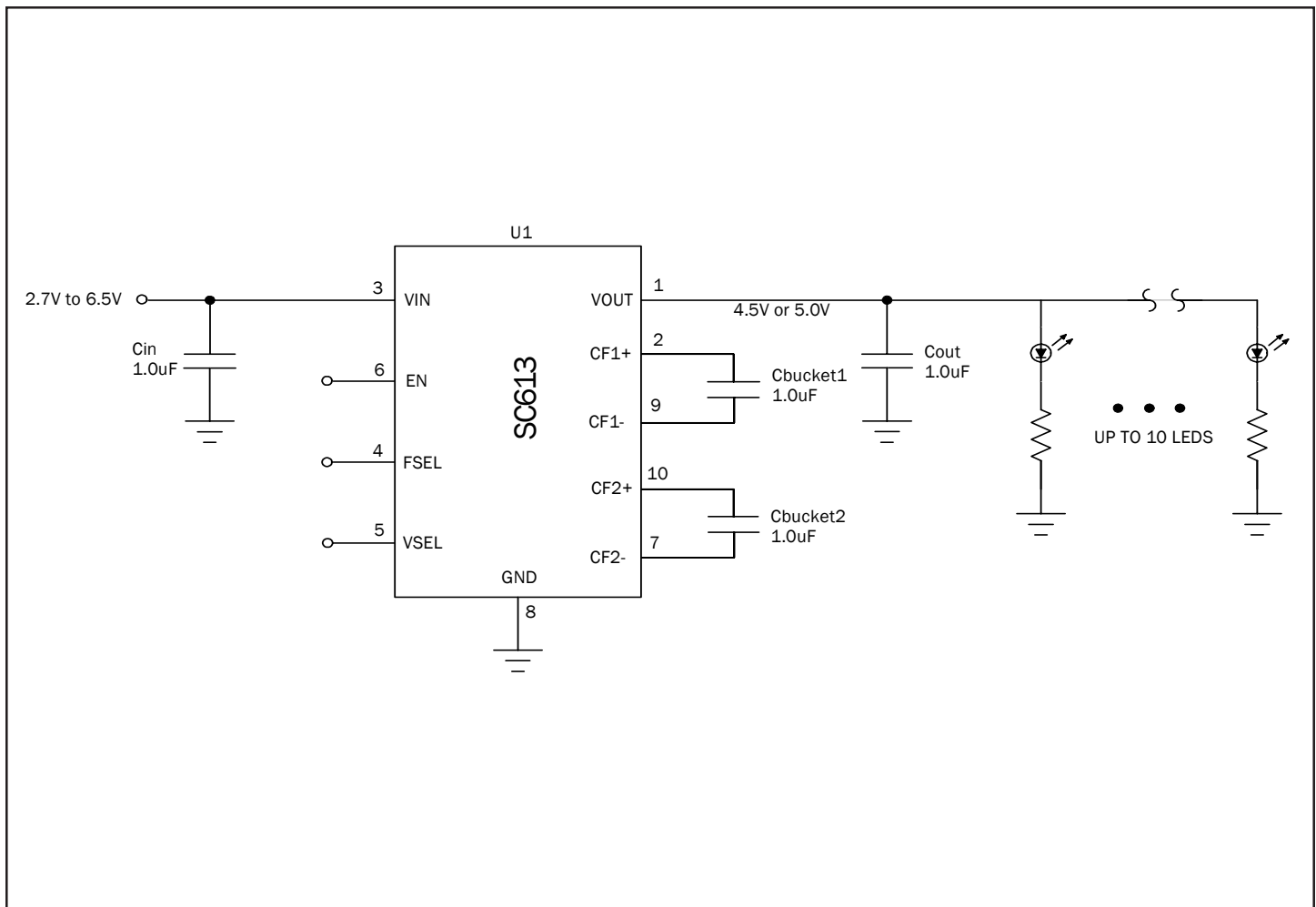

POWER MANAGEMENT
Absolute Maximum Ratings

Parameter	Symbol	Maximum	Units
Supply Voltage	V_{IN}	-0.3 to +7.0	V
Output Voltage	V_{OUT}	-0.3 to +7.0	V
V_{OUT} Short Circuit Duration	SC	Indefinite	
Thermal Resistance, Junction To Ambient (JEESD51 Standard Method)	θ_{JA}	31	°C/W
Operating Ambient	T_A	-40 to +85	°C
Junction Temperature Range	T_{JC}	-40 to +150	°C
Storage Temperature Range	T_{STG}	-65 to +150	°C
IR Reflow Temperature	T_{LEAD}	260	°C

Electrical Characteristics

Unless specified: $T_A = -40^\circ\text{C}$ to 85°C , $C_{in}=C_{bucket} = 1.0\mu\text{F}$ (ESR = 0.1 Ω), $C_{out}=1.0\mu\text{F}$ (ESR = 0.1 Ω), $V_{in} = 3.2\text{V}$ to 5.5V

Parameter	Symbol	Conditions	Min	Typ	Max	Units
Input Supply Voltage	V_{IN}		2.5		6.5	V
Quiescent Current	I_Q	Freq. = 262kHz, $I_{OUT} = 0\text{mA}$, $V_{IN} = 3.7\text{V}$		1.0	1.4	mA
		Freq. = 650kHz, $I_{OUT} = 0\text{mA}$, $V_{IN} = 3.7\text{V}$		2.1	2.8	mA
		Enable = 0			2	μA
Output Voltage	V_{OUT}	Static Load Regulation with VSEL = 1 $0\text{mA} < I_{OUT} < 100\text{mA}$	4.75	5.0	5.25	V
		Static Load Regulation with VSEL = 0 $0\text{mA} < I_{OUT} < 140\text{mA}$	4.275	4.5	4.725	V
Maximum Output Current	I_{OUT}	VSEL = 1	100			mA
		VSEL = 0	140			mA
Pump Frequency	f_{PUMP}	Enable = 1, FSEL = 0	-15%	262	+15%	kHz
		Enable = 1, FSEL = 1	-20%	650	+20%	kHz
Frequency Mode Transition Time	T_{LOCK}	Transition time from one frequency mode to any other frequency mode guaranteed by design		1		Period
Short Circuit Current	I_{SC}	$V_{OUT}=0\text{V}$, $I_{OUT} = I_{IN}$			600	mA
Input High Threshold	V_{IH}	All input pins (Enable, VSEL, FSEL)	1.3			V
Input Low Threshold	VIL	All input pins (Enable, VSEL, FSEL)			0.4	V

POWER MANAGEMENT
Electrical Characteristics

Unless specified: $T_A = -40^\circ\text{C}$ to 85°C , $C_{in}=C_{bucket} = 1.0\mu\text{F}$ (ESR = 0.1Ω), $C_{out}=1.0\mu\text{F}$ (ESR = 0.1Ω), $V_{in}= 3.2\text{V}$ to 5.5V

Parameter	Symbol	Conditions	Min	Typ	Max	Units
Input High Current	I_{IH}	All input pins (Enable, VSEL, FSEL)			10	μA
Input Low Current	I_{IL}	All input pins (Enable, VSEL, FSEL)			10	μA
Power Efficiency from Battery to Regulated Charge Pump Output	h	$V_{IN} = 3.0\text{V}$, $V_{OUT} = 5.0\text{V}$, $I_{OUT} = 50\text{mA}$ Freq.=262kHz		82.5		%
		$V_{IN} = 3.0\text{V}$, $V_{OUT} = 5.0\text{V}$, $I_{OUT} = 50\text{mA}$ Freq.=650kHz		81.5		%
Output Ripple Voltage	V_{PP}	freq = 262kHz, $I_{OUT} = 60\text{mA}$ ^{(1),(2)}		25	45	mV

Note:

(1) Peak to peak output ripple voltage with $C_{OUT}=C_{BUCKET}=1\mu\text{F}$ and X5R dielectric.

(2) Guaranteed by design.

(3) This device is ESD sensitive. Use of standard ESD handling precautions is required.

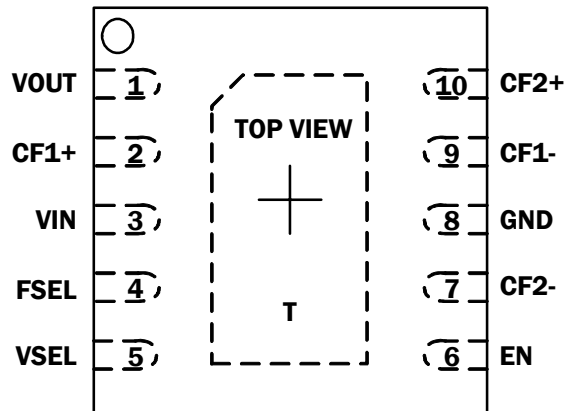
POWER MANAGEMENT
Pin Configuration

MLP-10 3X3 LEAD
Ordering Information

Device	Package ⁽¹⁾
SC613IMLTRT ⁽²⁾	MLP-10 3x3mm
SC613EVB	Evaluation Board

Note:

(1) Available in tape and reel only. A reel contains 3000 devices.

(2) Available in lead-free package only. This product is fully WEEE and RoHS compliant.

Pin Descriptions

Pin	Pin Name	Pin Function
1	VOUT	Output voltage regulated to 5.0V or 4.5V.
2	CF1+	Positive terminal of bucket capacitor 1.
3	VIN	Input voltage ranging from 2.5V to 6.5V.
4	FSEL	Logic input for selecting the operational frequency. FSEL= 0, freq = 262kHz; FSEL= 1, freq = 650kHz.
5	VSEL	Logic input for selecting the output voltage. VSEL = 1, VOUT = 5V; VSEL = 0, VOUT = 4.5V.
6	EN	Active-high enable. Bias current is less than 2uA when set low.
7	CF2-	Negative terminal of bucket capacitor 2.
8	GND	Ground.
9	CF1-	Negative terminal of bucket capacitor 1.
10	CF2+	Positive terminal of bucket capacitor 2.
T	Thermal Pad	Pad for heat sinking purposes - not connected internally. Connect to ground plane using multiple vias.

POWER MANAGEMENT

Block Diagram

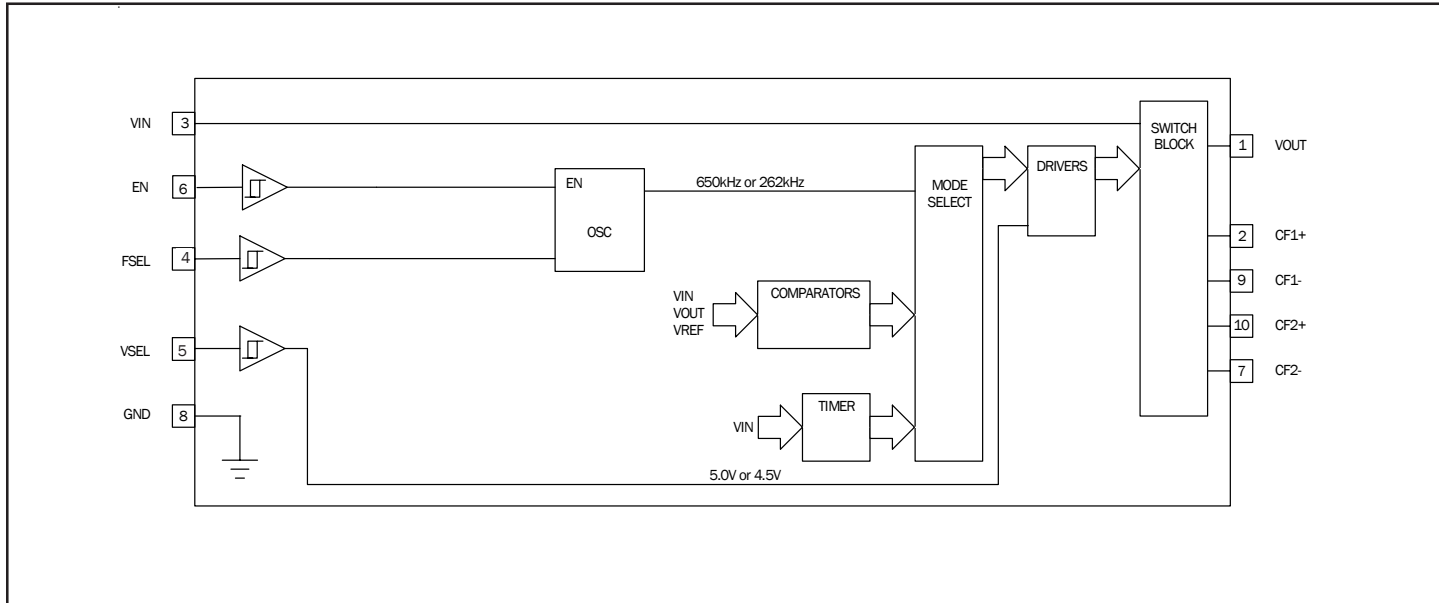

Applications Information

Charge Pump Doubler Type

The SC613 uses a voltage doubler circuit which is implemented with two switched or 'bucket' capacitors. Most charge pump doublers use only one bucket capacitor. Two bucket capacitors switching on alternate phases greatly reduce the output ripple voltage and also reduce the size requirement for the output capacitor.

Over Voltage Protection

The output is prevented from exceeding 6.0V. This feature allows the use of 6.3V ceramic capacitors.

Comparison with Other Regulation Methods

In many instances, a charge pump regulator is the best choice for portable power applications. These regulators offer many advantages over switch mode regulators. A smaller bill of materials, less layout area, lower component height, less noise, no EMF, and less overall circuit cost are typical reasons to use this type of regulation. The efficiency of a charge pump regulator often approaches and in some cases exceeds the efficiency of a switch mode regulator.

Inductors are often the largest and most expensive discrete component in a design. There are no inductors used in the SC613, so the inductor's cost and layout area are eliminated. The noise and EMF associated with the inductor are also eliminated.

The SC613's fixed frequency harmonics are an advantage in portable communications equipment, such as cellular telephones. The SC613 has distinct frequencies of operation, so the harmonics are predictable. The harmonics are not fixed in a switch mode regulator. Switch mode regulators have harmonics which vary due to the pulse width modulation used to regulate the output. Varying harmonics can be a problem because it may be more

difficult to ensure acceptable noise performance over the entire operating range.

Many switch mode regulators have increased voltage ripple on the output during pulse skipping mode due to the fact that there are large periods of time when no current is supplied to the output. The SC613 supplies current to the output continuously, so the voltage ripple is less than a switch mode regulator, even with greatly reduced output capacitance.

Frequency Selection

The FSEL input is for frequency selection. A logic High level at this input will set the clock frequency to 650kHz, while a logic Low sets the clock to 262kHz. Input from a uP or other device may be used to change the charge pump frequency at any time. The optimal frequency will depend upon the capacitor values, the load current, and the acceptable amount of output ripple.

Ripple Performance

Examples of the output ripple per charge pump frequency and output voltage are listed in the [Ripple Performance](#) table on page 5.

Efficiency

Efficiency for the SC613 is defined as,

$$\eta = \frac{V_O \cdot I_O}{V_{IN} \cdot (2 \cdot I_O + I_Q)}$$

where V_O = output voltage
 I_O = output current
 V_{IN} = input voltage
 I_Q = quiescent current [from Electrical Characteristics on page 2].

POWER MANAGEMENT

Applications Information (cont.)

Table 2 -Ripple Performance

T_A = 25°C, C_{in}=C_{out}=C_{bucket} = 1.0µF (ESR = 0.1Ω)

V _{OUT}	Freq. [kHz]	Ouput Ripple [mVp-p] at 100mA and Vin= 3.2V to 5.5V
5.0V	262	25
	650	15
4.5V	262	25
	650	15

Calculating Power Dissipation

The power dissipated by the SC613 is calculated as,

$$P_D = P_{IN} - P_{OUT}$$

$$P_D = V_{IN} \cdot (2 \cdot I_O + I_Q) - V_O \cdot I_O$$

Short Circuit and Over Temperature Protection

The output is current limited to 600mA to protect against short circuit conditions. Over temperature protection is also provided.

Design and Layout Considerations

The center pad “thermal slug” is not internally connected to ground, but should be connected to ground in the layout through vias connecting to the ground plane. Pin 8 can be routed directly to the center pad. A good ground plane connection is important to make effective use of the low thermal resistance of the MLP package.

Short Circuit and Over Temperature Protection

The output is current limited to 600mA to protect against short circuit conditions. Over temperature protection is also provided.

Design and Layout Considerations

The center pad “thermal slug” is not internally connected to ground, but should be connected to ground in the layout through vias connecting to the ground plane. Pin 8 can be routed directly to the center pad. A good ground plane connection is important to make effective use of the low thermal resistance of the MLP package.

POWER MANAGEMENT

Typical Characteristics

Efficiency vs. Load Current

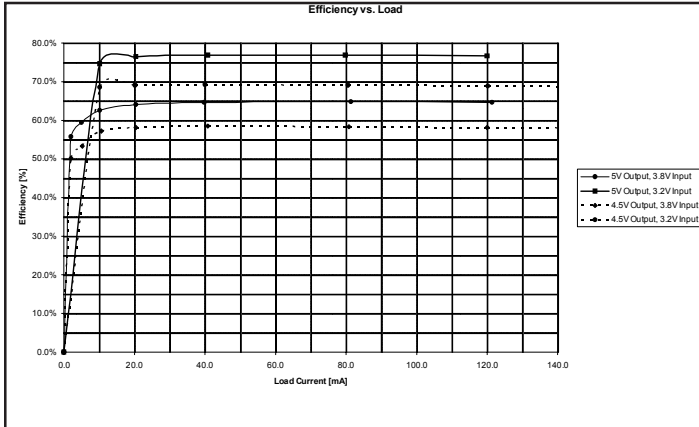

Line Regulation for 4.5V

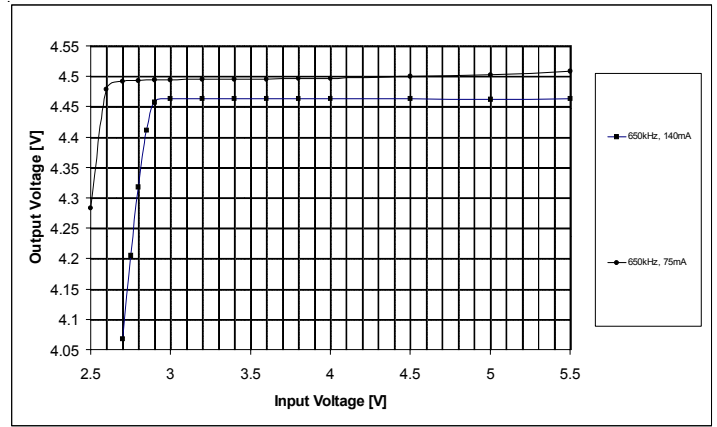

Load Regulation

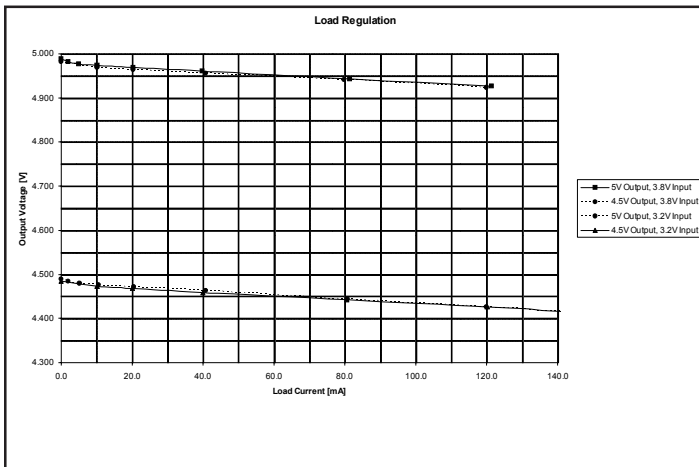

Line Regulation for 5.0V

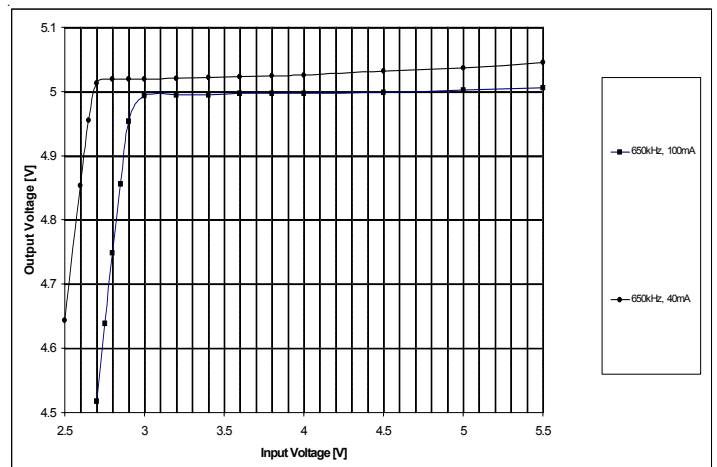

Quiescent Current

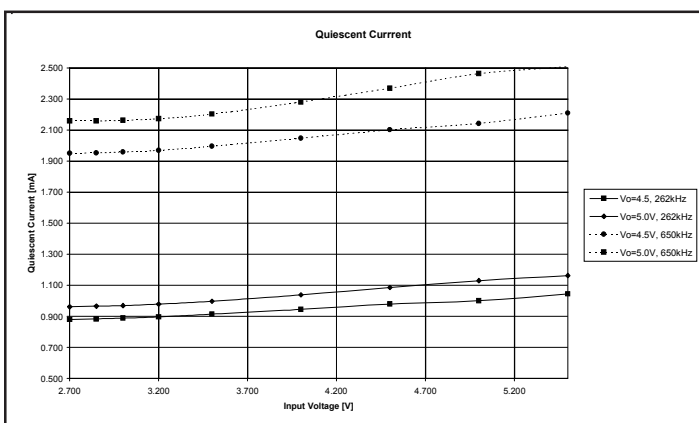

POWER MANAGEMENT

Start Up for 4.5V, 100mA

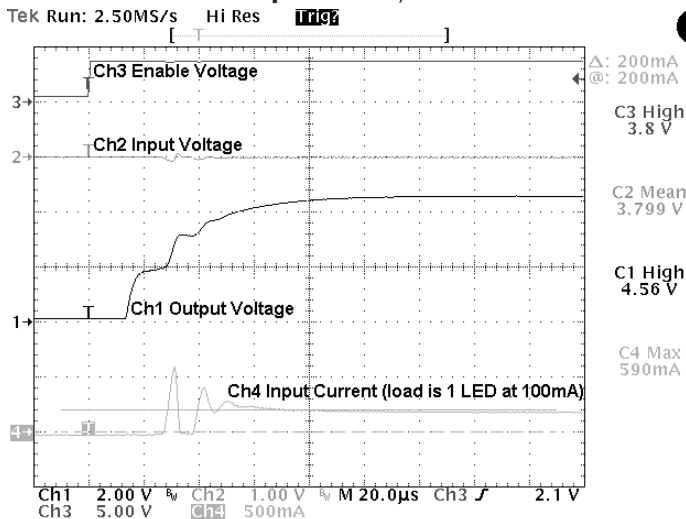

Start Up for 5.0V, 100mA

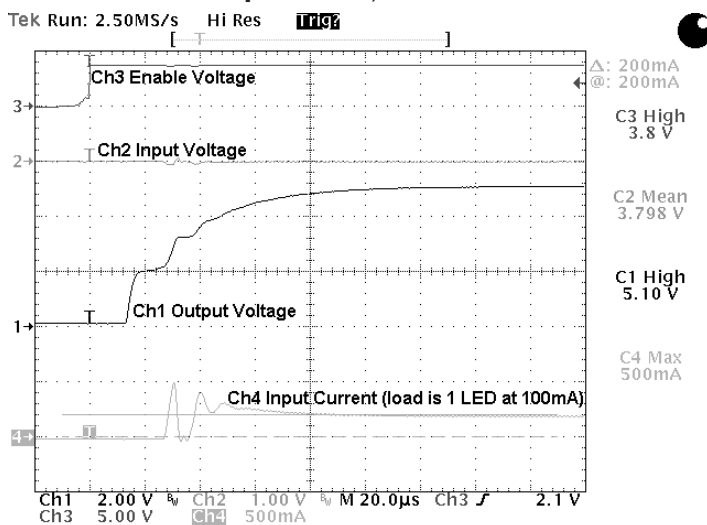

Recommended Minimum Low Pulse Width

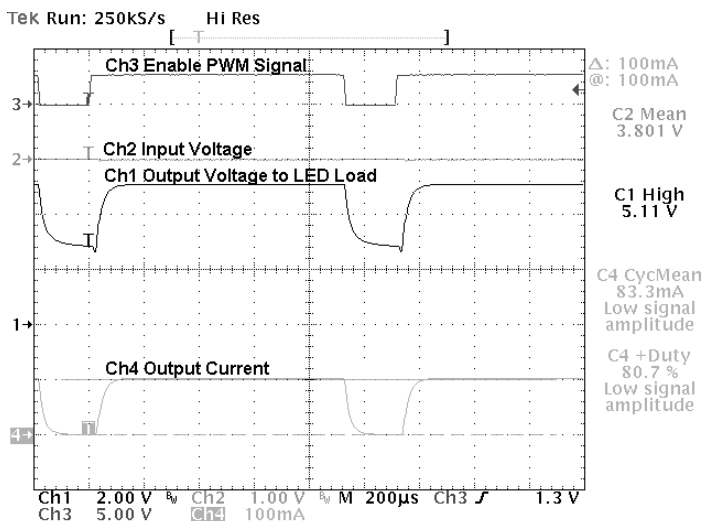

Recommended Minimum High Pulse Width

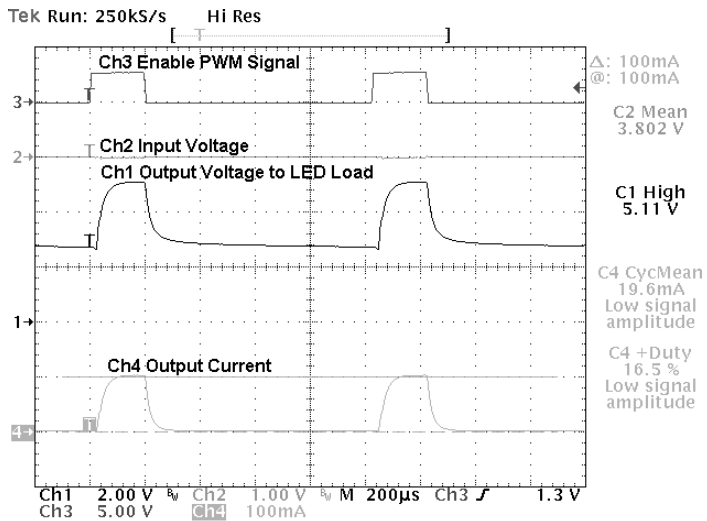

Recommended Minimum 100Hz PWM

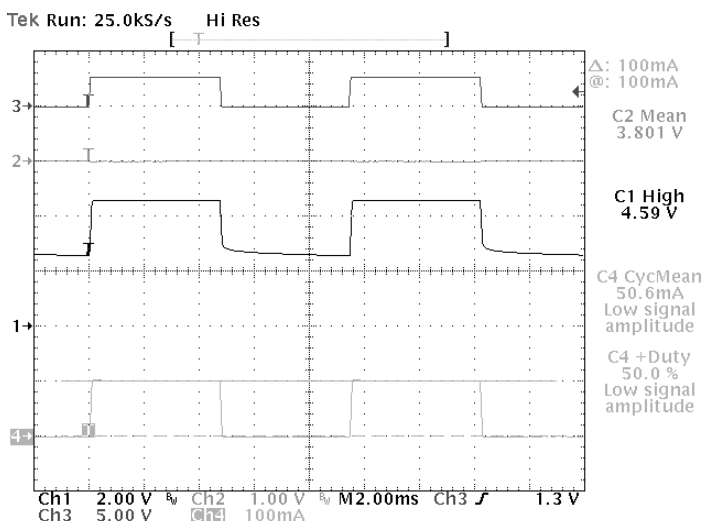

Recommended Maximum 500Hz PWM

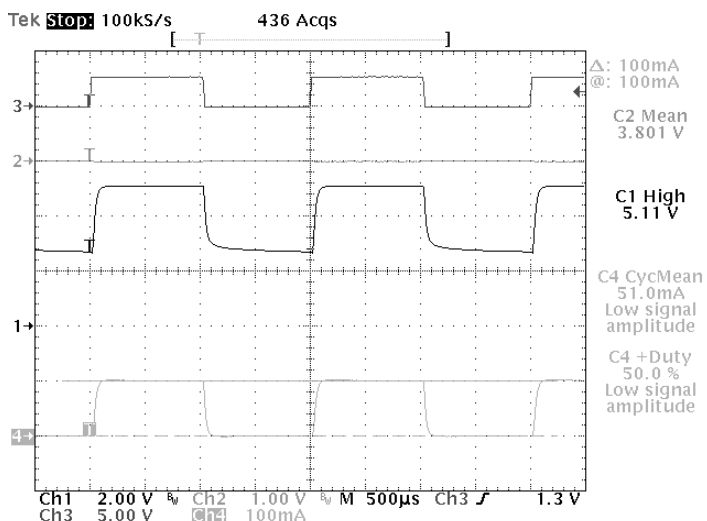

POWER MANAGEMENT

Output Ripple on 5.0V Output at 262kHz

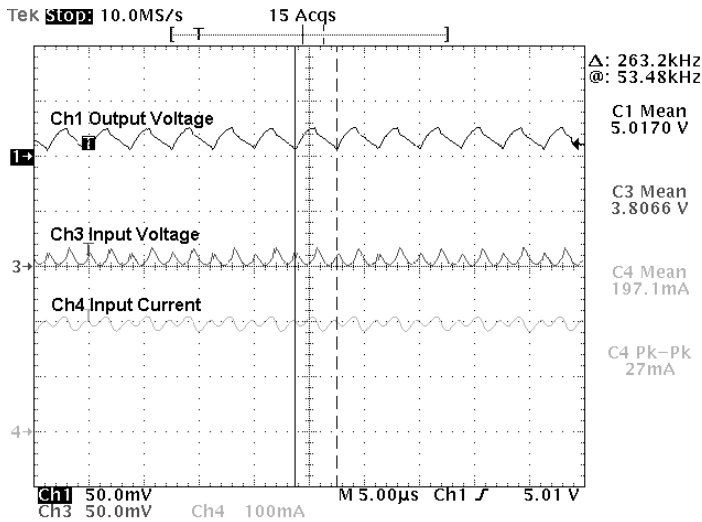

Output Ripple on 5.0V Output at 650kHz

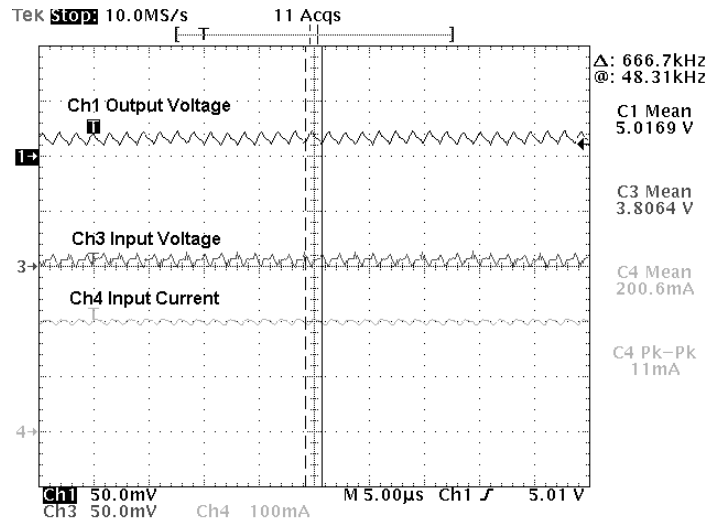

Output Ripple on 4.5V Output at 262kHz

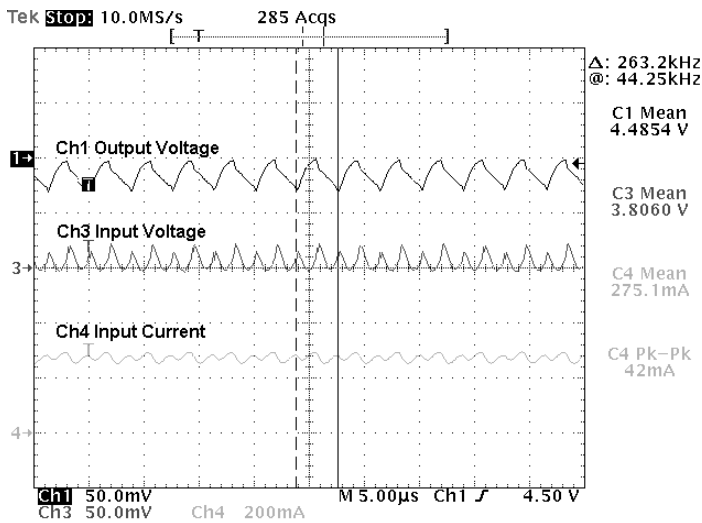

Output Ripple on 4.5V Output at 650kHz

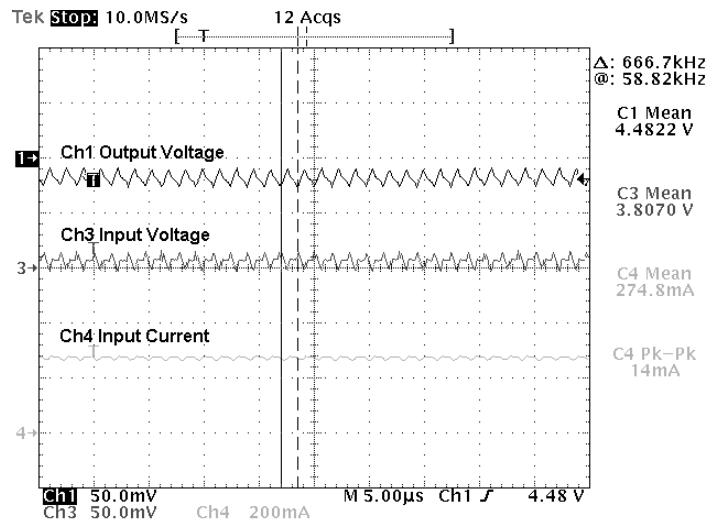

POWER MANAGEMENT

Application Schematic

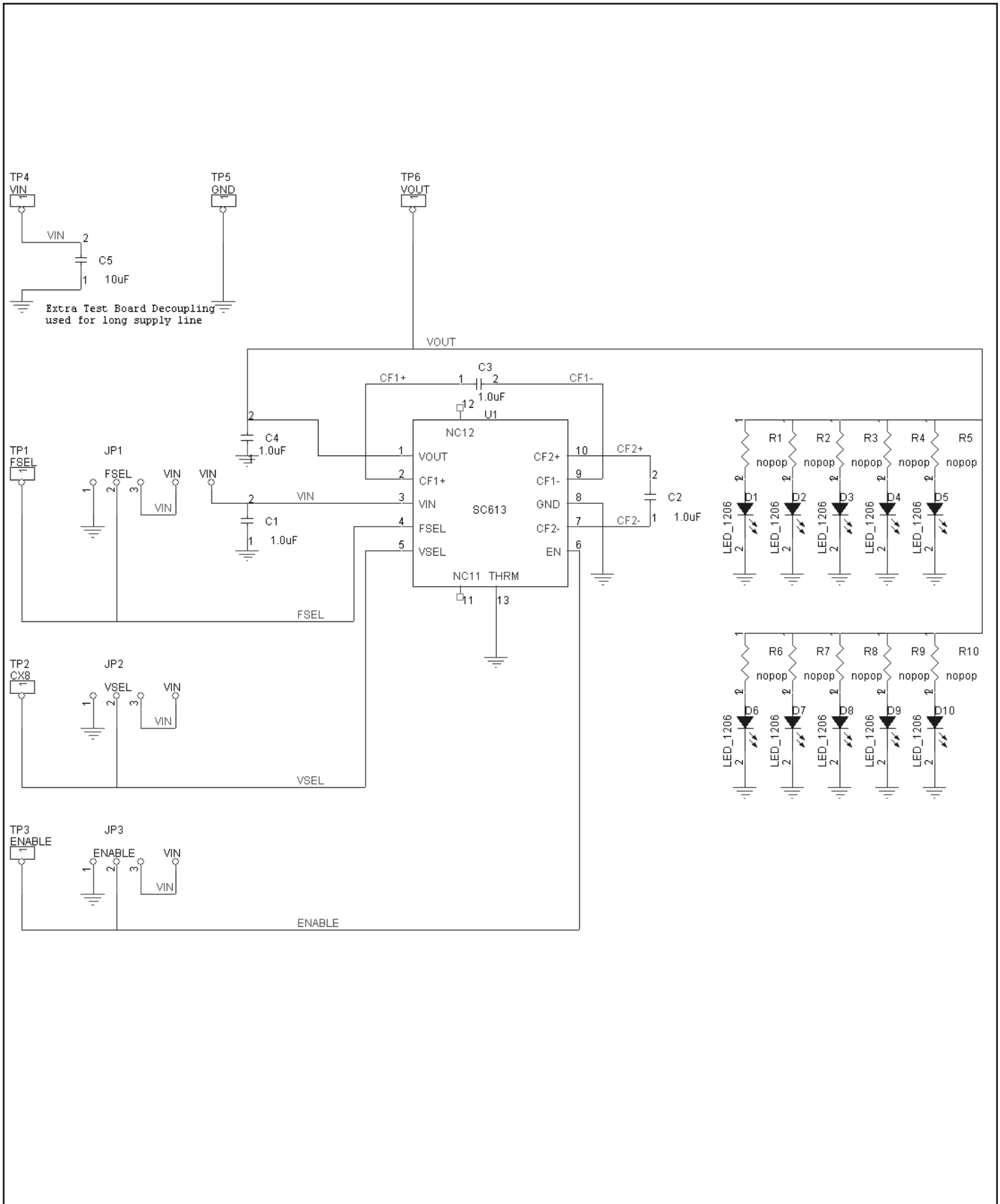

POWER MANAGEMENT

Evaluation Board Bill of Materials

Reference	Value	Comment
U1	SC613	MLP -Micro 10 lead 3x3mm.
C1, C2, C3, C4	1.0uF	Ceramic, low ESR type, voltage of 6.3V rating is acceptable for all capacitors.
C5	10uF	This extra capacitor supports usage of long power leads from a benchtop supply.
R1 through R10	-	Add limiting resistors to meet the requirements of the application on 0805 pads.
D1 through D10	-	Add white or blue LEDs to meet the requirements of the application on 1206 pads.

Marking Information

Top Marking

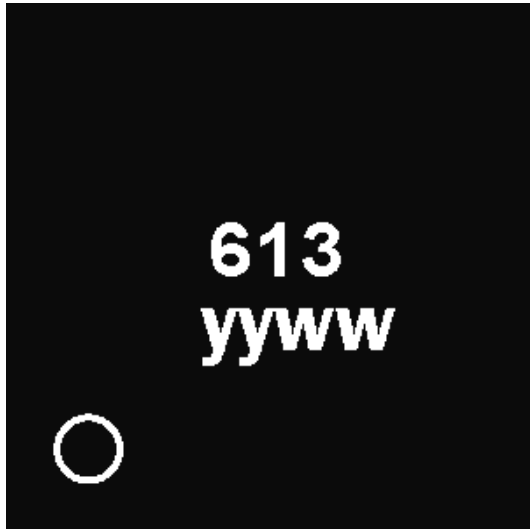

613

yyww

yyww = Datecode (Example: 0252)

POWER MANAGEMENT

Evaluation Board Gerber Plots

Top View

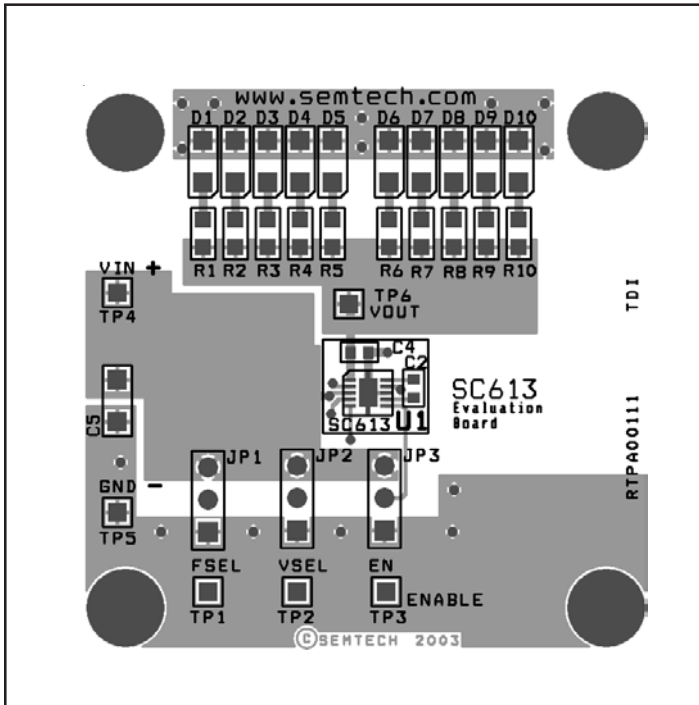

Bottom View

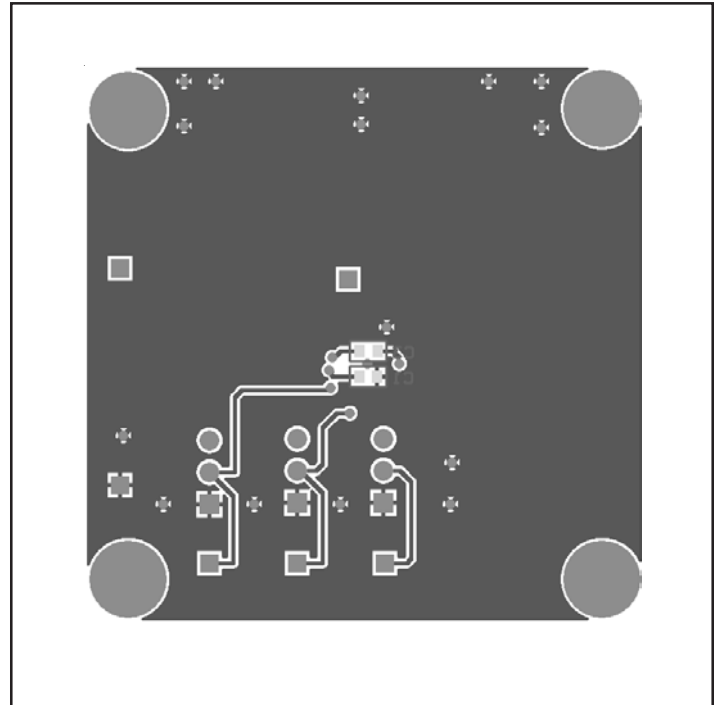

POWER MANAGEMENT

Land Pattern - MLP 3x3-10

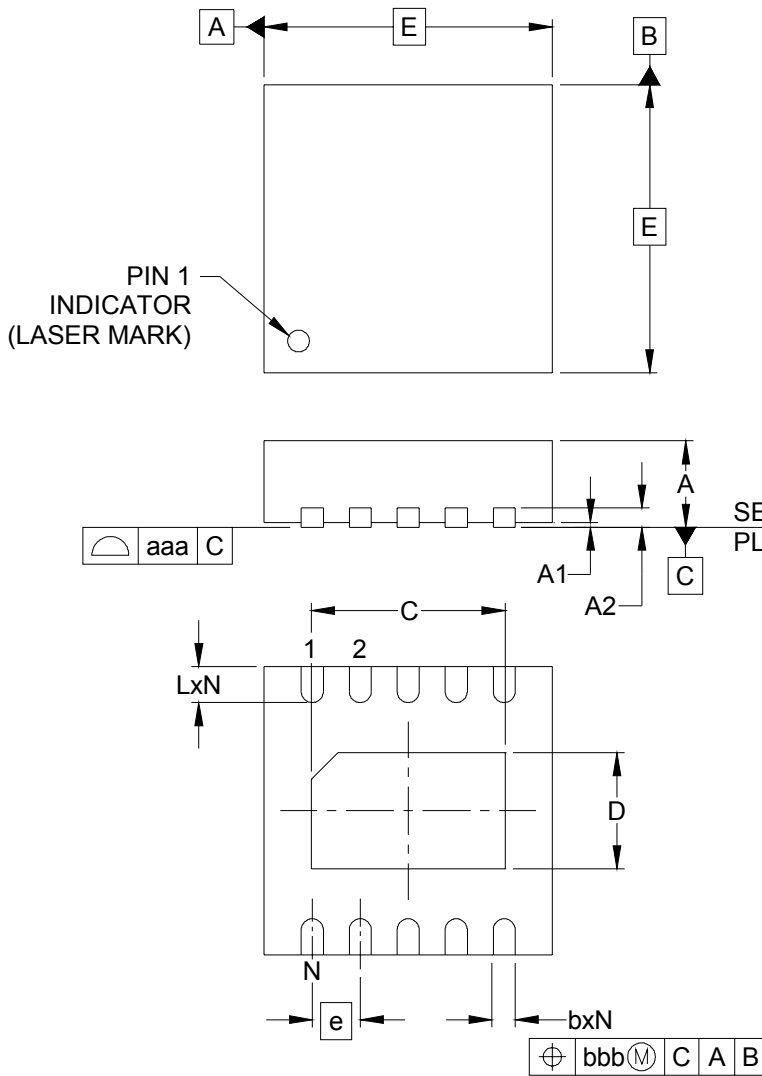

DIM	INCHES			MILLIMETERS		
	MIN	NOM	MAX	MIN	NOM	MAX
A	.031	-	.039	0.80	-	1.00
A1	.000	-	.002	0.00	-	0.05
A2	-	(.008)	-	-	(0.20)	-
b	.007	.009	.011	0.18	0.23	0.30
C	.074	.079	.083	1.87	2.02	2.12
D	.042	.048	.052	1.06	1.21	1.31
E	.114	.118	.122	2.90	3.00	3.10
e	.020 BSC			0.50 BSC		
L	.012	.016	.020	0.30	0.40	0.50
N	10			10		
aaa	.003			0.08		
bbb	.004			0.10		

NOTES:

1. CONTROLLING DIMENSIONS ARE IN MILLIMETERS (ANGLES IN DEGREES).
2. COPLANARITY APPLIES TO THE EXPOSED PAD AS WELL AS TERMINALS.

POWER MANAGEMENT

Outline Drawing - MLP 3x3-10

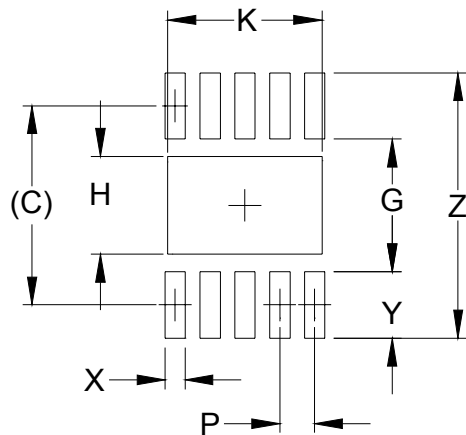

DIMENSIONS		
DIM	INCHES	MILLIMETERS
C	(.112)	(2.85)
G	.075	1.90
H	.055	1.40
K	.087	2.20
P	.020	0.50
X	.012	0.30
Y	.037	0.95
Z	.150	3.80

NOTES:

1. THIS LAND PATTERN IS FOR REFERENCE PURPOSES ONLY. CONSULT YOUR MANUFACTURING GROUP TO ENSURE YOUR COMPANY'S MANUFACTURING GUIDELINES ARE MET.

Contact Information

Taiwan Branch Tel: 886-2-2748-3380
Fax: 886-2-2748-3390

Korea Branch Tel: 82-2-527-4377
Fax: 82-2-527-4376

Shanghai Office Tel: 86-21-6391-0830
Fax: 86-21-6391-0831

Semtech Switzerland GmbH Tel: 81-3-6408-0950
Japan Branch Fax: 81-3-6408-0951

Semtech Limited (U.K.) Tel: 44-1794-527-600
Fax: 44-1794-527-601

Semtech France SARL Tel: 33-(0)169-28-22-00
Fax: 33-(0)169-28-12-98

Semtech Germany GmbH Tel: 49-(0)8161-140-123
Fax: 49-(0)8161-140-124

Semtech International AG is a wholly-owned subsidiary of Semtech Corporation, which has its headquarters in the U.S.A.

Visit us at: www.semtech.com