

POWER MANAGEMENT

Description

The SC606 is a very high efficiency charge pump white/color LED driver from the mAhXLife™ family of products. It is optimized for Li-Ion battery applications. The LED current is regulated to a value configured by the user through an I²C compatible serial interface.

LED outputs are current-matched for consistent LED brightness. Up to 6 LEDs are controlled in three zones for brightness control in multiple displays. The 6 LED outputs are divided into 3 pairs of LEDs. Each pair has current that is programmable independent of the other pairs. Any combination of LEDs may be turned on using the serial interface. The SC606 also has a float detect feature that disables any current driver during normal operation when an open-load condition is detected.

Patented low noise switching circuitry and constant output current allow the use of extremely small input and output capacitors.

Features

- ◆ Very High Efficiency Over 90% of Battery Life
- ◆ Current Regulation for 6 LEDs
- ◆ Current Matching Tolerance of +/- 3.5% from LED to LED
- ◆ Current Accuracy to +/- 6.5% of Specified Value
- ◆ Current Range per LED [0.5mA - 32mA]
- ◆ High Available Total LED Current = $6 \cdot I_{LED} = 120\text{mA}$
- ◆ I²C Bus Limited Compatibility SC606
- ◆ Low Shutdown Current: 0.1µA Typical
- ◆ Soft-Start /In-rush Current Limiting
- ◆ Short Circuit /Thermal Protection
- ◆ MLP-16 [4x4] Package
- ◆ 1.33MHz and 250kHz Programmable Fixed Frequency
- ◆ Separate Brightness Zones for Multiple Displays
- ◆ Three Charge Pump Modes of Operation: 1x, 1.5x and 2x
- ◆ Open LED Output Protection

Applications

- ◆ Cellular Phones
- ◆ LED Backlighting
- ◆ PDA Power Supplies
- ◆ Portable Devices
- ◆ Electronic Books
- ◆ Wireless Web Appliances

Typical Application Circuit

Patent Pending

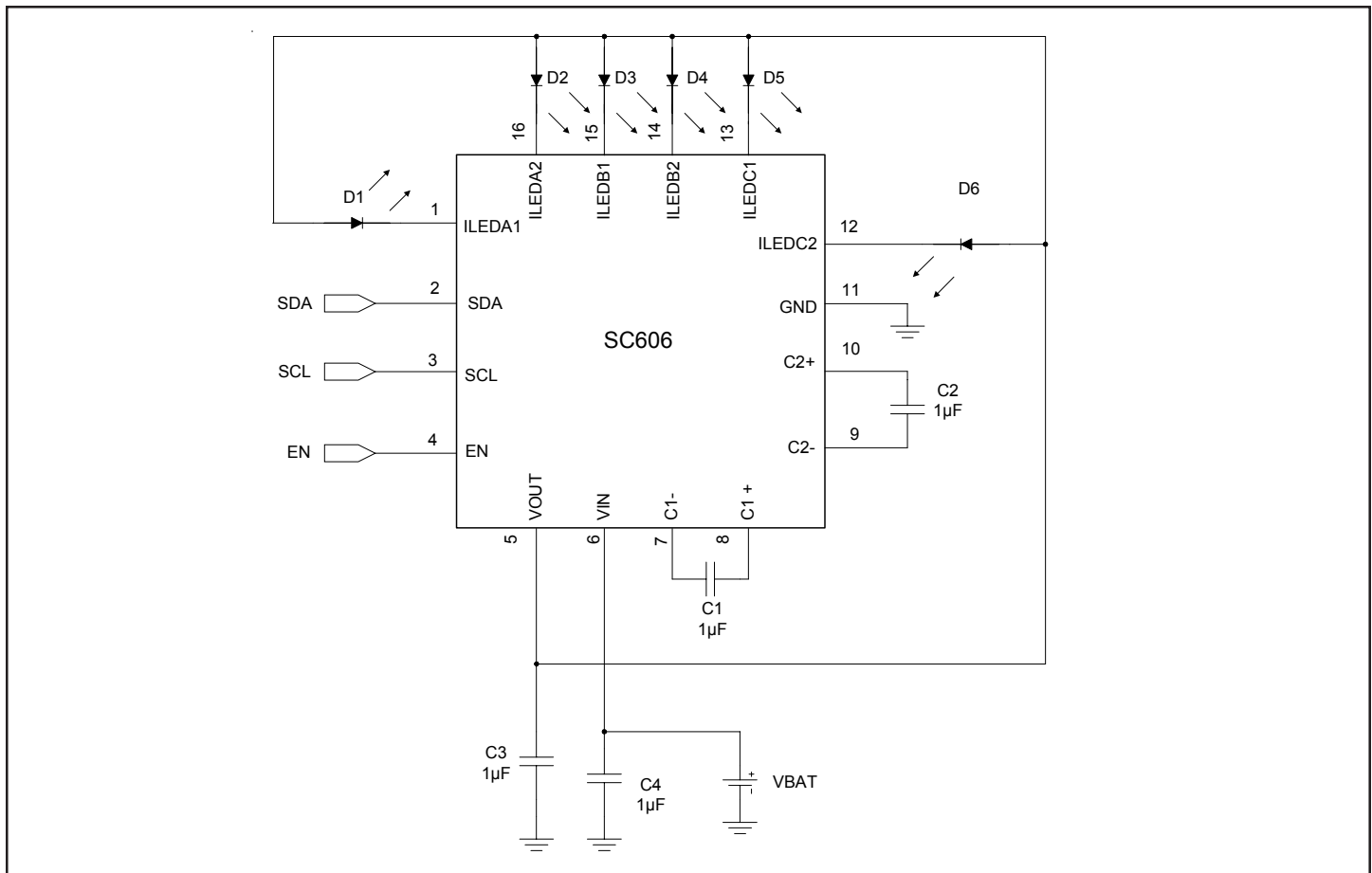

POWER MANAGEMENT
Absolute Maximum Ratings

Exceeding the specifications below may result in permanent damage to the device or device malfunction. Operation outside of the parameters specified in the Electrical Characteristics section is not required.

Parameter	Symbol	Maximum	Units
Supply Voltage	V_{IN}	-0.3 to +6.0	V
Output Voltage	V_{OUT}	-0.3 to +6.0	V
VOOUT Short Circuit Duration	SC	Indefinite	
Thermal Resistance, Junction to Ambient ⁽¹⁾	θ_{JA}	40	°C/W
Thermal Resistance, Junction to Case	θ_{JC}	2.4	°C/W
Operating Ambient	T_A	-40 to +85	°C
Junction Temperature Range	T_{JC}	-40 to +150	°C
Storage Temperature Range	T_{STG}	-65 to +150	°C
IR Reflow Temperature SC606AIMLTRT	T_{LEAD}	260	°C

1) Calculated from package in still air, mounted to 3" x 4.5", 4 layer FR4 PCB with thermal vias under the exposed pad per JESD51 standards.

Electrical Characteristics

Unless specified: $T_A = -40^\circ\text{C}$ to 85°C , $V_{IN} = 2.85\text{V}$ to 5.5V , $C1 = C2 = C3 = C4 = 1.0\mu\text{F}$ (ESR = 0.03Ω), Typical values @ $T_A = 25^\circ\text{C}$, LED $V_F = 3.4\text{V}$. This device is ESD sensitive. Use of standard ESD handling precautions is required.

Parameter	Symbol	Condition	Min	Typ	Max	Units
Quiescent Current	I_Q	1x mode, $I_{OUT} = 0\text{mA}$, $V_{IN} = 4.2\text{V}$		1500	2000	μA
		1.5x mode and 2x mode, $I_{OUT} = 0\text{mA}$		3	4	mA
		Enable = 0, $V_{IN} = 4.2\text{V}$		0.1	7	μA
LED Current Accuracy	$I_{LED-ERR}$	$0.5\text{mA} \leq I_{LEDn} \leq 4.0\text{mA}^{(1)(2)}$ $3.2\text{V} \leq V_{IN} \leq 4.2\text{V}$	-260	± 100	260	μA
		$4.5\text{mA} \leq I_{LEDn} \leq 15\text{mA}$ $3.2\text{V} \leq V_{IN} \leq 4.2\text{V}$	-6.5	± 2	6.5	%
		$15.5\text{mA} \leq I_{LEDn} \leq 32\text{mA}^{(3)}$ $3.2\text{V} \leq V_{IN} \leq 4.2\text{V}$	-9	± 3	9	%
Current Matching	$I_{LED-to-LED}$	$0.5\text{mA} \leq I_{LEDn} \leq 4.0\text{mA}^{(2)}$ $3.2\text{V} \leq V_{IN} \leq 4.2\text{V}$	-140	± 50	140	μA
		$4.5\text{mA} \leq I_{LEDn} \leq 15\text{mA}$ $3.2\text{V} \leq V_{IN} \leq 4.2\text{V}$	-3	± 1	3	%
		$15.5\text{mA} \leq I_{LEDn} \leq 32\text{mA}^{(3)}$ $3.2\text{V} \leq V_{IN} \leq 4.2\text{V}$	-3.75	± 1.5	3.75	%
1x mode to 1.5x mode falling	$V_{TRANS1X}$	$I_{OUT} = 60\text{mA}$, $I_{LEDn} = 10\text{mA}^{(1)}$		3.58		V
1.5x mode to 2x mode falling transition voltage	$V_{TRANS1.5X}$	$I_{OUT} = 60\text{mA}$, $I_{LEDn} = 10\text{mA}^{(1)}$		2.98		V

POWER MANAGEMENT
Electrical Characteristics (Cont.)

Parameter	Symbol	Condition	Min	Typ	Max	Units
Oscillator Frequency	f_{OSC}	ON/OFF# Status Register = X1XXXXX ⁽⁴⁾	1.13	1.33	1.53	MHz
Oscillator Frequency	f_{OSC}	ON/OFF# Status Register = X0XXXXX ⁽⁴⁾	212.5	250	287.5	kHz
Input Current Limit ⁽²⁾	I_{LIMIT}	$3.2V \leq V_{IN} \leq 4.2V$ Short circuit applied from V_{OUT} to GND		220	850	mA
Input High Threshold	V_{IH}	Input high logic threshold	1.6			V
Input Low Threshold	V_{L}	Input low logic threshold			0.4	V
Input High Current	I_{IH}	$V_{IH} = V_{IN}$			10	μA
Input Low Current	I_{L}	$V_{L} = GND$			10	μA
I²C Interface						
limited compliance with slave mode I ² C Combined Format Philips I ² C specification version 2.1 dated January, 2000						
Digital Input Voltage	V_{L}				0.4	V
	V_{IH}		1.6			
SDA Output Low Level	V_{OL}	$I_{DIN}(SDA) = 3mA$			0.4	V
		$I_{DIN}(SDA) = 6mA$			0.6	V
Digital Input Current	I_{DG}		-0.2		0.2	μA
I/O Pin Capacitance	C_{IN}			10		pF
I²C Timing						
Clock Frequency	f_{SCL}			400	440	kHz
SCL Low Period	t_{LOW}		1.3			μs
SCL High Period	t_{High}		0.6			μs
Data Hold Time	t_{HD_DAT}		0			μs
Data Setup Time	t_{SU_DAT}		100			ns
Setup Time - Repeated Start Condition	t_{SU_STA}		0.6			μs
Hold Time - Repeated Start Condition	t_{HD_STA}		0.6			μs
Setup Time for Stop Condition	t_{SU_STA}		0.6			μs

POWER MANAGEMENT

Electrical Characteristics (Cont.)

Parameter	Symbol	Condition	Min	Typ	Max	Units
Bus-Free Time Between STOP and START	t_{BUF}		1.3			μs
Interface Start-up Time	t_{EN}	Bus Start-up Time (after EN is pulled high)			350	μs

Notes:

- 1) I_{LEDn} = any LED's current from D1, D2, D3, D4, D5 and D6.
- 2) Guaranteed by design.
- 3) Maximum total of LED currents not to exceed 120mA.
- 4) X = Don't care.

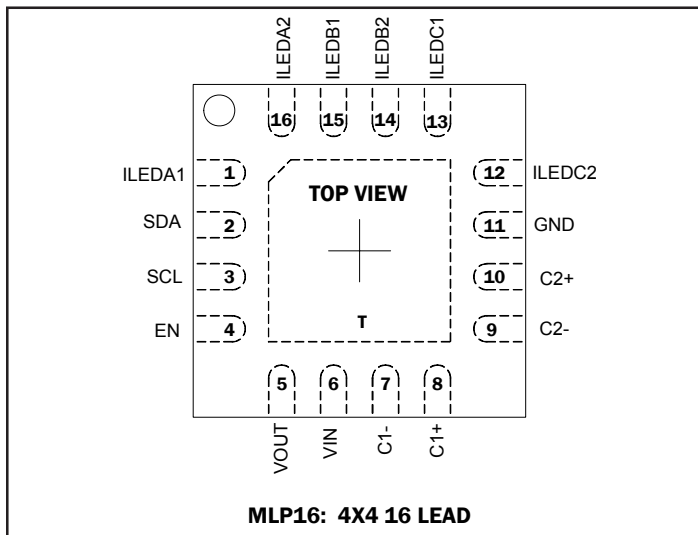
POWER MANAGEMENT
Pin Configuration

Ordering Information

DEVICE	PACKAGE ⁽¹⁾
SC606AIMLTRT ⁽²⁾	MLP4x4-16
SC606AEVB	Evaluation Board

Notes:

- 1) Available in tape and reel only. A reel contains 3000 devices.
 2) Available in lead-free package only. This product is fully WEEE and RoHS compliant.

Pin Descriptions

Pin	Pin Name	Pin Function
1	ILEDA1	Current sink for LEDA1 (If not in use, pin may be left open or grounded).
2	SDA	Bi-directional serial data line.
3	SCL	Serial bus clock input.
4	EN	Active high enable. Bias current is typically 0.1 μ F when EN is low.
5	VOUT	Output of the charge pump. Connect a 1 μ F capacitor from VOUT to ground.
6	VIN	Input voltage. Connect a 1 μ F capacitor from VIN to ground. For improved performance when using 250 kHz and 1.5x mode, increase the capacitor to 4.7 μ F ~ 10 μ F.
7	C1-	Negative terminal of bucket capacitor 1.
8	C1+	Positive terminal of bucket capacitor 1.
9	C2-	Negative terminal of bucket capacitor 2.
10	C2+	Positive terminal of bucket capacitor 2.
11	GND	Ground.
12	ILEDC2	Current sink for LEDC2 (If not in use, pin may be left open or grounded).
13	ILEDC1	Current sink for LEDC1 (If not in use, pin may be left open or grounded).
14	ILEDB2	Current sink for LEDB2 (If not in use, pin may be left open or grounded).
15	ILEDB1	Current sink for LEDB1 (If not in use, pin may be left open or grounded).
16	ILEDA2	Current sink for LEDA2 (If not in use, pin may be left open or grounded).
T	Thermal Pad	Pad for heat sinking purposes. Connect to ground plane using multiple vias. Not connected internally.

POWER MANAGEMENT

Block Diagram

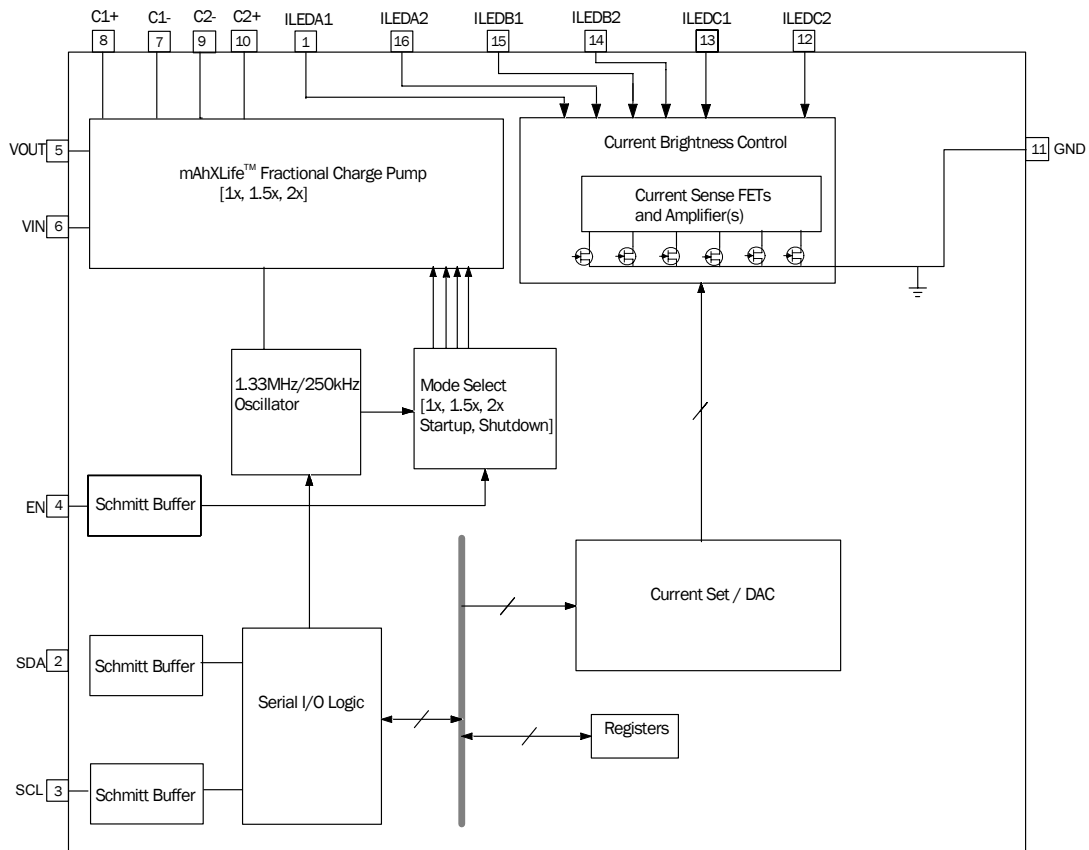

POWER MANAGEMENT
Applications Information
Detailed Description

The SC606 contains a fractional charge pump, mode selection circuit, serial I/O logic, serial data registers and current regulation circuitry for 6 LED outputs. All are depicted in the Block Diagram on page 6.

The fractional charge pump multiplies the input voltage by 1, 1.5 or 2 times the input voltage. The charge pump switches at a fixed frequency that is bit selectable to 1.33MHz or 250kHz. The default frequency is 1.33MHz. 250kHz may require additional input capacitance of up to 10µF. The charge pump does not switch during 1x mode, saving power and improving efficiency.

The mode selection circuit automatically selects the mode as 1x, 1.5x or 2x based on circuit conditions such as LED voltage, input voltage and load current. 1x is the most efficient mode, followed by 1.5x and 2x modes. At lower voltages a stronger mode may be needed to maintain regulation. If so, the mode will change first to 1.5x and then later to 2x. 2x mode usually operates for a much shorter run time compared to 1x mode, and 2x mode maintains the output until the battery is discharged to 2.85V or less. The LED requiring the highest voltage drop will determine the output voltage needed to drive all outputs with sufficient anode voltage. Comparing all cathodes and regulating V_{OUT} for the LED with the lowest cathode voltage ensures sufficient bias for all LEDs.

The LED outputs are controlled through the serial data registers, found on page 10 in Table 1. LED on/off functions are independently controlled, so that any combination of LEDs may be switched on. LED current is set per LED pair. For example, when ILEDA1 and ILEDA2 are both on, ILEDA1 = ILEDA2. But ILEDA1 and ILEDA2 do not have to be on at the same time.

Six (6) current regulating circuits sink matched currents from the LEDs on a per pair basis. LEDs with matched forward voltage will produce the best possible matched currents. For best matching performance it is recommended that the LED to LED difference, ΔV_F, be under 250mV.

Designing for Lowest Possible Battery Current

The battery current and efficiency of the SC606 are mostly dependent on the charge pump mode of operation. To get the best performance from the SC606 it is better to use LEDs with consistently lower V_F voltage. Lower V_F will keep the charge pump in 1x mode longer and will use less battery current, extending the run time of the battery.

Mode transition voltages V_{TRANS1X} and V_{TRANS1.5X} can be estimated by the following equations:

$$V_{\text{TRANS1X}} = V_F + V_{\text{ILEDn}} + (\# \text{ of LEDs used}) \cdot I_{\text{LED}} \cdot 0.83$$

$$V_{\text{TRANS1.5X}} = [V_F + V_{\text{ILEDn}} + (\# \text{ of LEDs used}) \cdot I_{\text{LED}} \cdot 10.1] / 1.5$$

where, V_F is the anode to cathode voltage and V_{ILEDn} is the voltage at the ILED pin. Typically V_{ILED} = 120mV and I_{LED} is the LED current.

Power efficiency can be estimated for the intended battery voltage range.

$$\eta = [V_{\text{OUT}} \cdot I_{\text{OUT}} / V_{\text{IN}} \cdot (I_{\text{OUT}} \cdot \text{Mode} + I_Q)] \cdot 100 \%$$

where, V_{OUT} = V_F + V_{ILEDn}
 and I_Q = 1.5mA, in 1x mode
 I_Q = 3mA, in 1.5x or 2x mode

Quiescent Current

I_Q at no load will vary with the device state. A sequence of steps is now described which will demonstrate the effect that the device state has on I_Q when VIN = 3.8V.

(1) After power up (Enable High) and before any serial communication, the I_Q is approximately 2.2mA. This is because the output defaults to 5V and the charge pump is active to support the 5V. The charge pump also defaults to 1.33MHz.

(2) After power up if the clock is changed to 250kHz, the I_Q will decrease to 1mA.

(3) If one LED is set on at 0.5mA, the input current will be 1.5mA. For a typical white LED, the 5V output is much higher than necessary, so the charge pump will switch off and the output will adjust to a normal value for the LED, typically around 3.5V.

(4) Turn off the LED and I_Q = I_{IN} = 80µA with Enable = High. This is the lowest power state while Enable = High.

I_{LED} Accuracy

I_{LED} is determined by the status of registers at 00h, 01h and 02h. The tolerance of the I_{LED} current is +/-6.5% at the 10mA setting. For example, if the data registers are configured so that each LED current should be 10mA, the actual LED currents would be between 9.35mA and 10.65mA (+/-6.5%). All 6 outputs meet this requirement over the industrial temperature range. To calculate the error I_{LED-ERR} [%], use the formula,

$$I_{\text{LED-ERR}} [\%] = \pm \left[\frac{I_{\text{LED(measured)}} - I_{\text{LED}}}{I_{\text{LED}}} \right] \cdot 100\%$$

POWER MANAGEMENT

Applications Information (Cont.)

Current Matching

Current Matching refers to the ΔI from an LED compared to the average of the minimum and maximum value of all LEDs that are programmed for the same current.

$$I_{\text{LED-LED-ERR}} [\%] = \left(\frac{\frac{I_{\text{MAX}}}{I_{\text{MAX}} + I_{\text{MIN}}} - 1}{2} \right) \cdot 100\%$$

or

$$\left(\frac{\frac{I_{\text{MIN}}}{I_{\text{MAX}} + I_{\text{MIN}}} - 1}{2} \right) \cdot 100\%$$

which reduces to \pm

$$\left(\frac{I_{\text{MAX}} - I_{\text{MIN}}}{I_{\text{MAX}} + I_{\text{MIN}}} \right) \cdot 100\%$$

1x Mode, 1.5x Mode and 2x Mode

1x Mode, 1.5x Mode and 2x Mode all refer to the charge pump configuration. These modes multiply the input voltage and ensure that V_{OUT} is high enough for current to be regulated in the LEDs.

Mode Transition Voltage

Mode transition voltage refers to the input voltage at the point when the charge pump changes from a weaker mode (lower numerically) to a stronger mode (higher numerically). V_{TRANS1X} is the transition from 1x to 1.5x mode, and $V_{\text{TRANS1.5X}}$ is the transition from 1.5x to 2x mode.

POWER MANAGEMENT

Applications Information (Cont.)

I²C Communication

The SC606 interface uses a limited version of the combined format protocol as described in the Phillips I²C Bus Specification version 2.1. With this format, the Start condition and the Slave Address are both repeated. Data formatting must be a single byte only. Note that the SC606 can only operate on an I²C bus using the limited combined format protocol. If any other I²C data formatting is used on the bus the SC606 may exhibit false acknowledges to the commands. The I²C Slave Address is 1100110. I²C Fast Mode is supported at 400kbit/s. For more information about the I²C combined protocol refer to the I²C Bus Specification from Philips Semiconductors.

Slave Address

Following a start condition, the bus master outputs the address of a slave device. The 7 bit slave address for the SC606 is 1100110. The address is followed by a least significant bit (LSB). The LSB determines the data direction.

MSB							LSB
1	1	0	0	1	1	0	R/W

Data Formatting

Write Format

S	Slave Address	W	A	1 Byte Register Address	A	Sr	Slave Address	W	A	1 Byte Only nData	A	P
---	---------------	---	---	-------------------------	---	----	---------------	---	---	-------------------	---	---

Read Format

S	Slave Address	W	A	1 Byte Register Address	A	Sr	Slave Address	R	A	1 Byte Only nData	B	P
---	---------------	---	---	-------------------------	---	----	---------------	---	---	-------------------	---	---

- S : Start Condition
- W : '0' = Write
- R : '1' = Read
- A : Acknowledge, sent by slave
- B : Acknowledge, sent by master
- Sr: Repeated Start Condition
- P : Stop Condition

Slave Address: 7 bit
 Register Address: 8 bit
 Data: 8 bit

POWER MANAGEMENT

Applications Information (Cont.)

Table 1 - SERIAL DATA REGISTERS

Register Name	Register Address [8-bit Hexadecimal]	Registers' Bit Function Table							
		B7	B6	B5	B4	B3	B2	B1	B0
LED_A12 Reg	00h	X	X	Refer to Table 2 on Page 11					
LED_B12 Reg	01h								
LED_C12 Reg	02h								
ON/OFF# Reg	03h	0	Frequency 1 = 250kHz 0 = 1.33MHz	LEDC2 1 = On 0 = Off	LEDC1 1 = On 0 = Off	LEDB2 1 = On 0 = Off	LEDB1 1 = On 0 = Off	LEDA2 1 = On 0 = Off	LEDA1 1 = On 0 = Off

Note: X = Don't care
 1 = Logic High
 0 = Logic Low

POWER MANAGEMENT

Applications Information (Cont.)

Table 2 - DAC Codes For LED Output Current

LED Current [mA]	B7	B6	B5	B4	B3	B2	B1	B0	Decimal
0.5	X	X	0	0	0	0	0	0	0
1.0	X	X	0	0	0	0	0	1	1
1.5	X	X	0	0	0	0	1	0	2
2.0	X	X	0	0	0	0	1	1	3
2.5	X	X	0	0	0	1	0	0	4
3.0	X	X	0	0	0	1	0	1	5
3.5	X	X	0	0	0	1	1	0	6
4.0	X	X	0	0	0	1	1	1	7
4.5	X	X	0	0	1	0	0	0	8
5.0	X	X	0	0	1	0	0	1	9
5.5	X	X	0	0	1	0	1	0	10
6.0	X	X	0	0	1	0	1	1	11
6.5	X	X	0	0	1	1	0	0	12
7.0	X	X	0	0	1	1	0	1	13
7.5	X	X	0	0	1	1	1	0	14
8.0	X	X	0	0	1	1	1	1	15
8.5	X	X	0	1	0	0	0	0	16
9.0	X	X	0	1	0	0	0	1	17
9.5	X	X	0	1	0	0	1	0	18
10.0	X	X	0	1	0	0	1	1	19
10.5	X	X	0	1	0	1	0	0	20
11.0	X	X	0	1	0	1	0	1	21
11.5	X	X	0	1	0	1	1	0	22
12.0	X	X	0	1	0	1	1	1	23
12.5	X	X	0	1	1	0	0	0	24
13.0	X	X	0	1	1	0	0	1	25
13.5	X	X	0	1	1	0	1	0	26
14.0	X	X	0	1	1	0	1	1	27
14.5	X	X	0	1	1	1	0	0	28
15.0	X	X	0	1	1	1	0	1	29
15.5	X	X	0	1	1	1	1	0	30
16.0	X	X	0	1	1	1	1	1	31

LED Current [mA]	B7	B6	B5	B4	B3	B2	B1	B0	Decimal
16.5	X	X	1	0	0	0	0	0	32
17.0	X	X	1	0	0	0	0	1	33
17.5	X	X	1	0	0	0	1	0	34
18.0	X	X	1	0	0	0	1	1	35
18.5	X	X	1	0	0	1	0	0	36
19.0	X	X	1	0	0	1	0	1	37
19.5	X	X	1	0	0	1	1	0	38
20.0	X	X	1	0	0	1	1	1	39
20.5	X	X	1	0	1	0	0	0	40
21.0	X	X	1	0	1	0	0	1	41
21.5	X	X	1	0	1	0	1	0	42
22.0	X	X	1	0	1	0	1	1	43
22.5	X	X	1	0	1	1	0	0	44
23.0	X	X	1	0	1	1	0	1	45
23.5	X	X	1	0	1	1	1	0	46
24.0	X	X	1	0	1	1	1	1	47
24.5	X	X	1	1	0	0	0	0	48
25.0	X	X	1	1	0	0	0	1	49
25.5	X	X	1	1	0	0	1	0	50
26.0	X	X	1	1	0	0	1	1	51
26.5	X	X	1	1	0	1	0	0	52
27.0	X	X	1	1	0	1	0	1	53
27.5	X	X	1	1	0	1	1	0	54
28.0	X	X	1	1	0	1	1	1	55
28.5	X	X	1	1	1	0	0	0	56
29.0	X	X	1	1	1	0	0	1	57
29.5	X	X	1	1	1	0	1	0	58
30.0	X	X	1	1	1	0	1	1	59
30.5	X	X	1	1	1	1	0	0	60
31.0	X	X	1	1	1	1	0	1	61
31.5	X	X	1	1	1	1	1	0	62
32.0	X	X	1	1	1	1	1	1	63

Note: X = Don't care

POWER MANAGEMENT

Typical Characteristics

Efficiency for 6 LEDs at 20mA and 3.31V

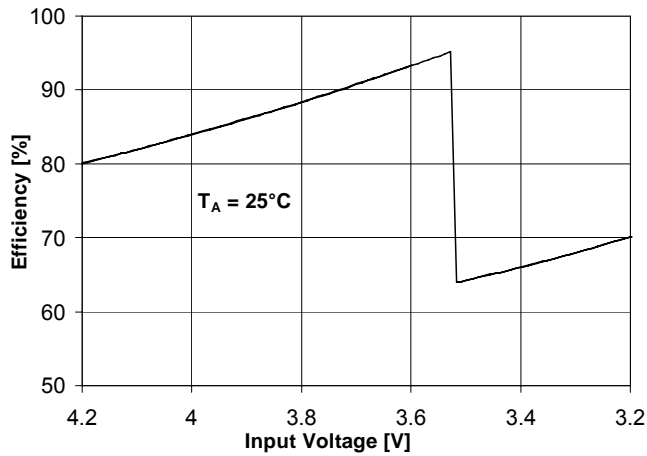

Efficiency for 6 LEDs at 10mA and 3.31V

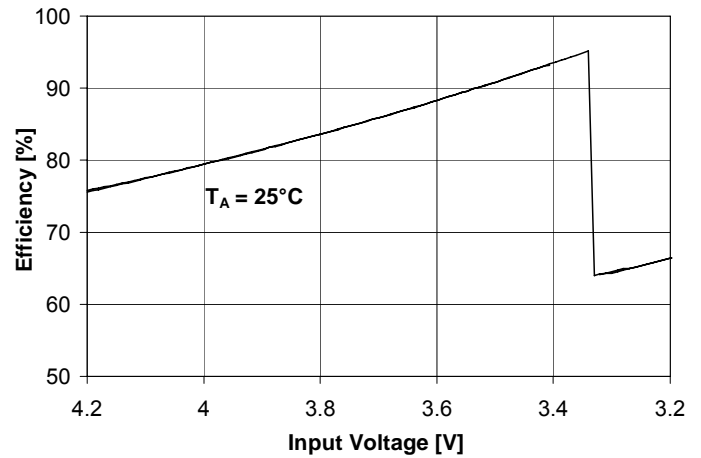

Ripple in 1x Mode for 6 LEDs at 20mA

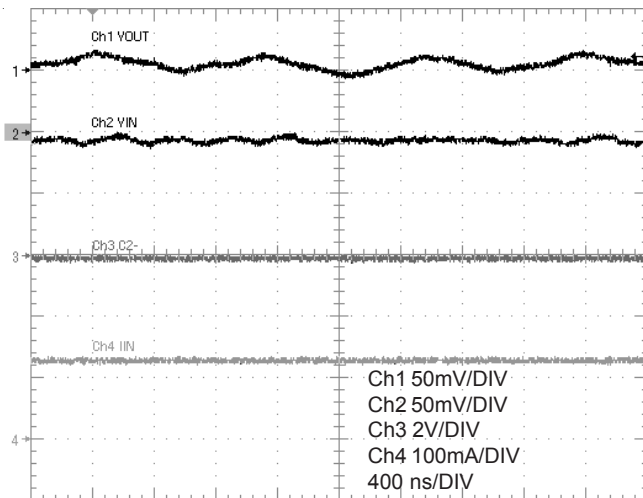

Startup

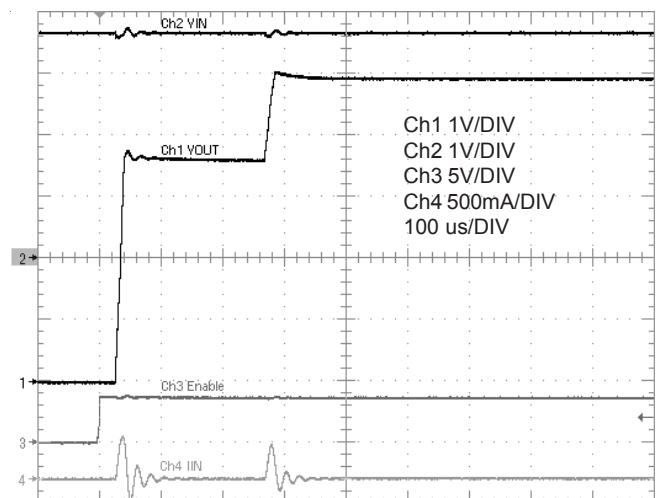

1.33MHz Ripple in 1.5x Mode for 6 LEDs at 20mA

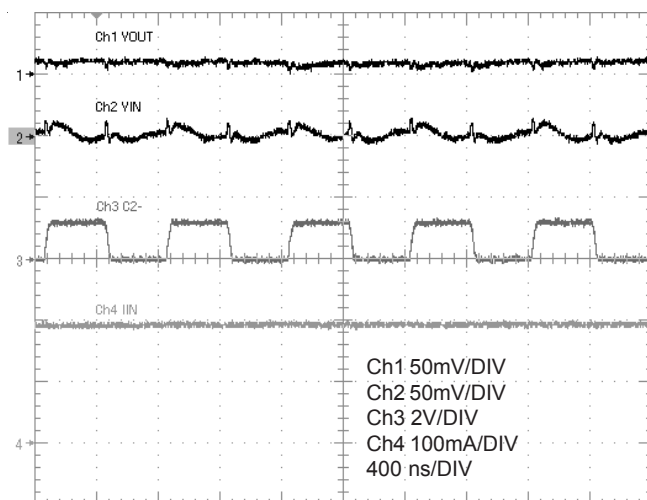

250kHz Ripple in 1.5x Mode for 6 LEDs at 20mA

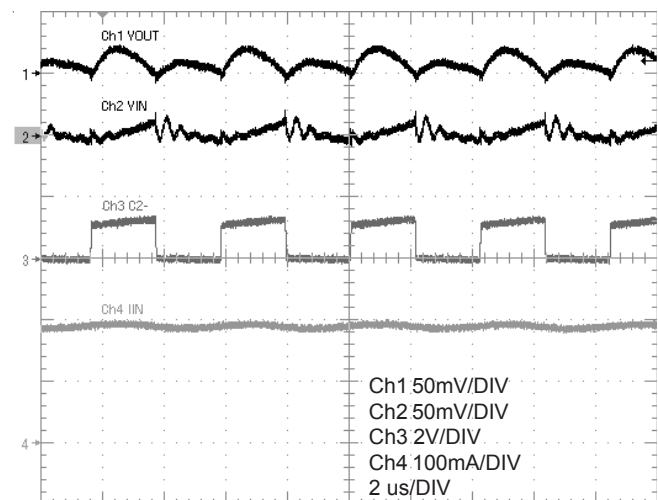

POWER MANAGEMENT

Typical Characteristics (Cont.)

1.33MHz Ripple in 2x Mode for 6 LEDs at 20mA

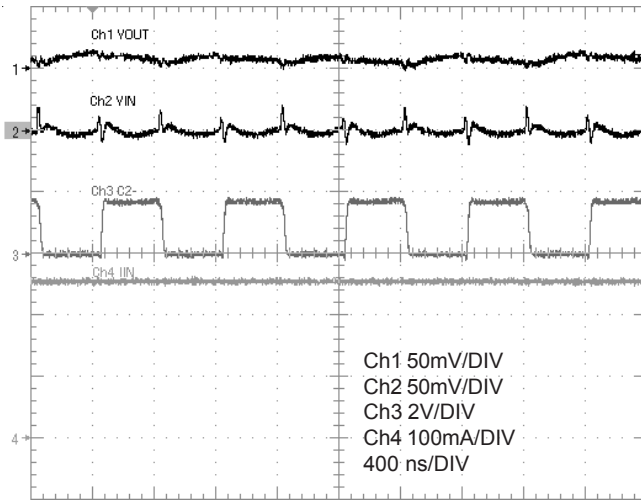

250kHz Ripple in 2x Mode for 6 LEDs at 20mA

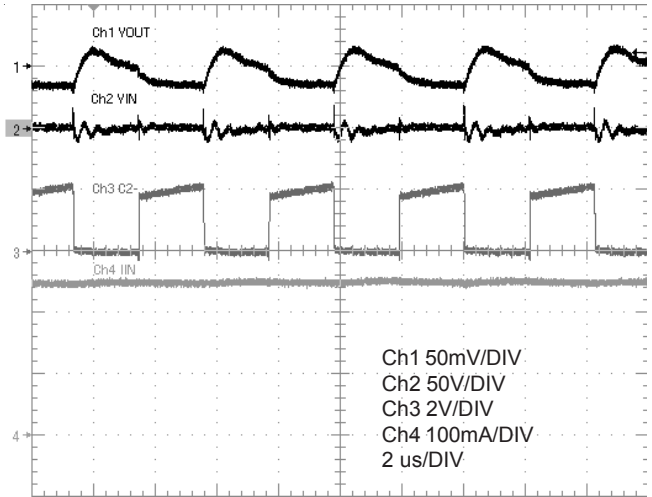

I_Q , LEDs Turned Off

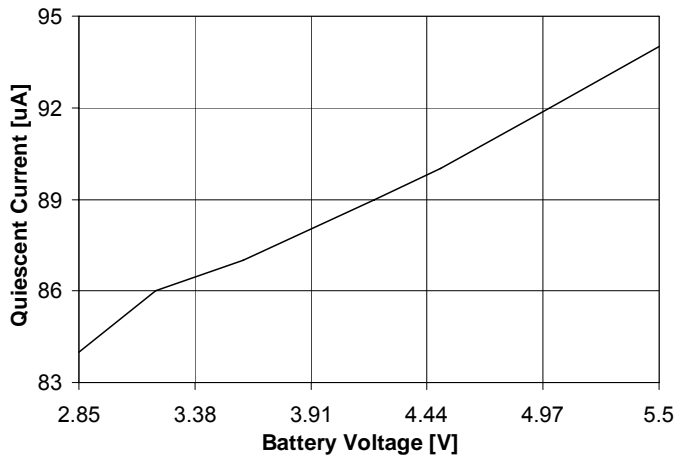

POWER MANAGEMENT

Evaluation Board Schematic

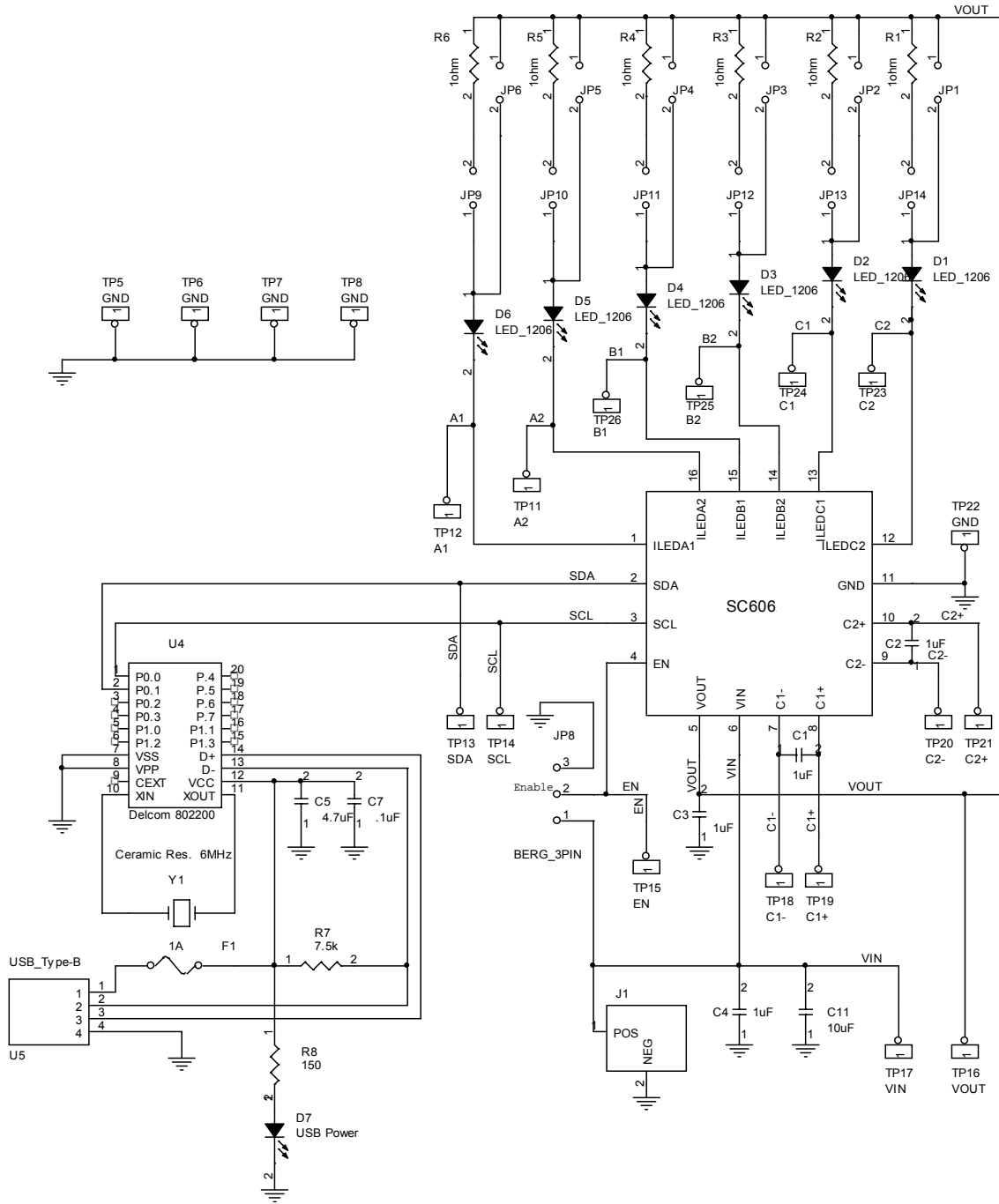

POWER MANAGEMENT

Evaluation Board Bill of Material

ITEM	QUANTITY	REFERENCE	PART
1	4	C1, C2, C3, C4	1UF X5R
2	1	C5	4.7UF
3	1	C7	.1UF
4	1	C11	10UF
5	6	D1, D2, D3, D4, D5, D6	LED_1206 NICHIA NSCW100
6	1	D7	USB POWER
7	1	F1	1A
8	12	JP1, JP2, JP3, JP4, JP5, JP6, JP9, JP10, JP11, JP12, JP13, JP14	2PIN JUMPER
9	1	JP8	3PIN JUMPER
10	1	J1	BATTERY INPUT
11	6	R1, R2, R3, R4, R5, R6	1OHM
12	1	R7	7.5K
13	1	R8	150
14	5	TP5, TP6, TP7, TP8, TP22	GND
15	1	TP11	A2
16	1	TP12	A1
17	1	TP13	SDA
18	1	TP14	SCL
19	1	TP15	EN
20	1	TP16	VOUT
21	1	TP17	VIN
22	1	TP18	C1-
23	1	TP19	C1+
24	1	TP20	C2-
25	1	TP21	C2+
26	1	TP23	C2
27	1	TP24	C1
28	1	TP25	B2
29	1	TP26	B1
30	1	U1	SC606
31	1	U4	DELCOM 802200
32	1	U5	USB_TYPE-B
33	1	Y1	CERAMIC RES. 6MHZ

POWER MANAGEMENT

Evaluation Board Gerber Plots

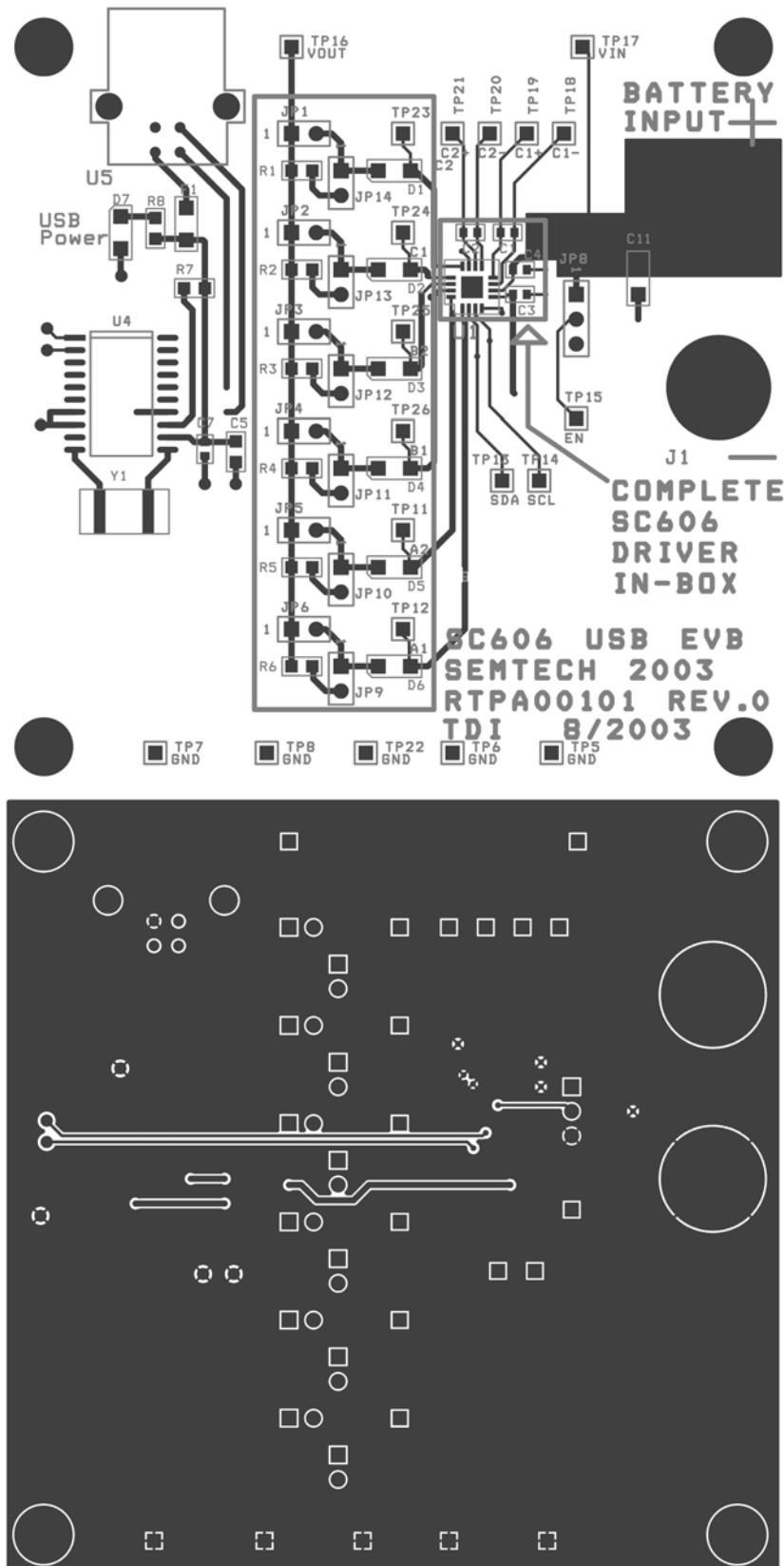

POWER MANAGEMENT

Outline Drawing - MLP-16 [4x4]

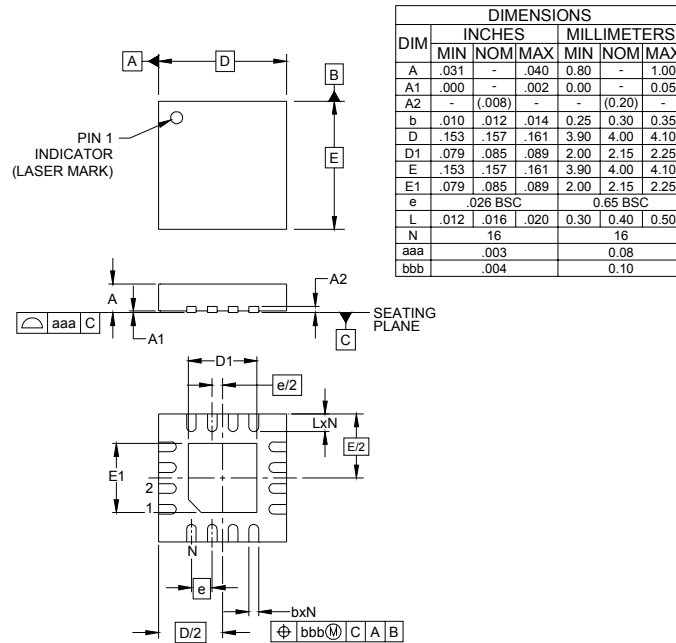

- NOTES:
1. CONTROLLING DIMENSIONS ARE IN MILLIMETERS (ANGLES IN DEGREES).
 2. COPLANARITY APPLIES TO THE EXPOSED PAD AS WELL AS THE TERMINALS.

Marking Information

Marking for SC606AIML



yyww = Datecode (Example: 0422)

POWER MANAGEMENT

Land Pattern - MLP-16 [4x4]

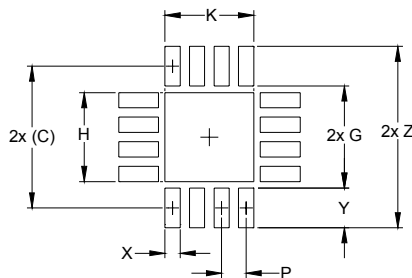

DIMENSIONS		
DIM	INCHES	MILLIMETERS
C	(.156)	(3.95)
G	.122	3.10
H	.091	2.30
K	.091	2.30
P	.026	0.65
X	.016	0.40
Y	.033	0.85
Z	.189	4.80

NOTES:

1. THIS LAND PATTERN IS FOR REFERENCE PURPOSES ONLY. CONSULT YOUR MANUFACTURING GROUP TO ENSURE YOUR COMPANY'S MANUFACTURING GUIDELINES ARE MET.

Contact Information for Semtech International AG

Taiwan Branch	Tel: 886-2-2748-3380 Fax: 886-2-2748-3390	Semtech Switzerland GmbH Japan Branch	Tel: 81-3-6408-0950 Fax: 81-3-6408-0951
Korea Branch	Tel: 82-2-527-4377 Fax: 82-2-527-4376	Semtech Limited (U.K.)	Tel: 44-1794-527-600 Fax: 44-1794-527-601
Shanghai Office	Tel: 86-21-6391-0830 Fax: 86-21-6391-0831	Semtech France SARL	Tel: 33-(0)169-28-22-00 Fax: 33-(0)169-28-12-98
Semtech International AG is a wholly-owned subsidiary of Semtech Corporation, which has its headquarters in the U.S.A.		Semtech Germany GmbH	Tel: 49-(0)8161-140-123 Fax: 49-(0)8161-140-124

Visit us at: www.semtech.com