

POWER MANAGEMENT

Description

The SC4508 is a low voltage current mode switching regulator controller that drives a P-channel power MOSFET with programmable switching frequency. It can be configured in either buck or buck boost (inverting) converters. The converters can be operated from 2.7V to 15V input voltage range. The typical operating supply current is 3mA and a shutdown pin allows the user to turn the controller off reducing it to less than 200 μ A. The output voltage can be adjusted by external resistor divider. The switching frequency is programmable up to 1.5MHz, allowing small inductor and capacitor values to minimize PCB space. The operating current level is programmable via an external sense resistor. Accessible reference voltage allows users to make output voltage as low as they want.

Features

- ◆ Wide input voltage range 2.7V to 15V
- ◆ Programmable output voltage
- ◆ Programmable switching frequency up to 1.5MHz
- ◆ Buck or buck boost(inverting) configuration
- ◆ Current mode control with slope compensation
- ◆ Very low quiescent current in shutdown mode
- ◆ Accessible reference voltage
- ◆ MLPQ-12 package

Applications

- ◆ Low power point of use converters
- ◆ Single or multiple output low power converters
- ◆ Positive and/or negative output voltage
- ◆ DSL cards
- ◆ Graphic cards
- ◆ I/O cards
- ◆ Negative bias supplies

Typical Application Circuits

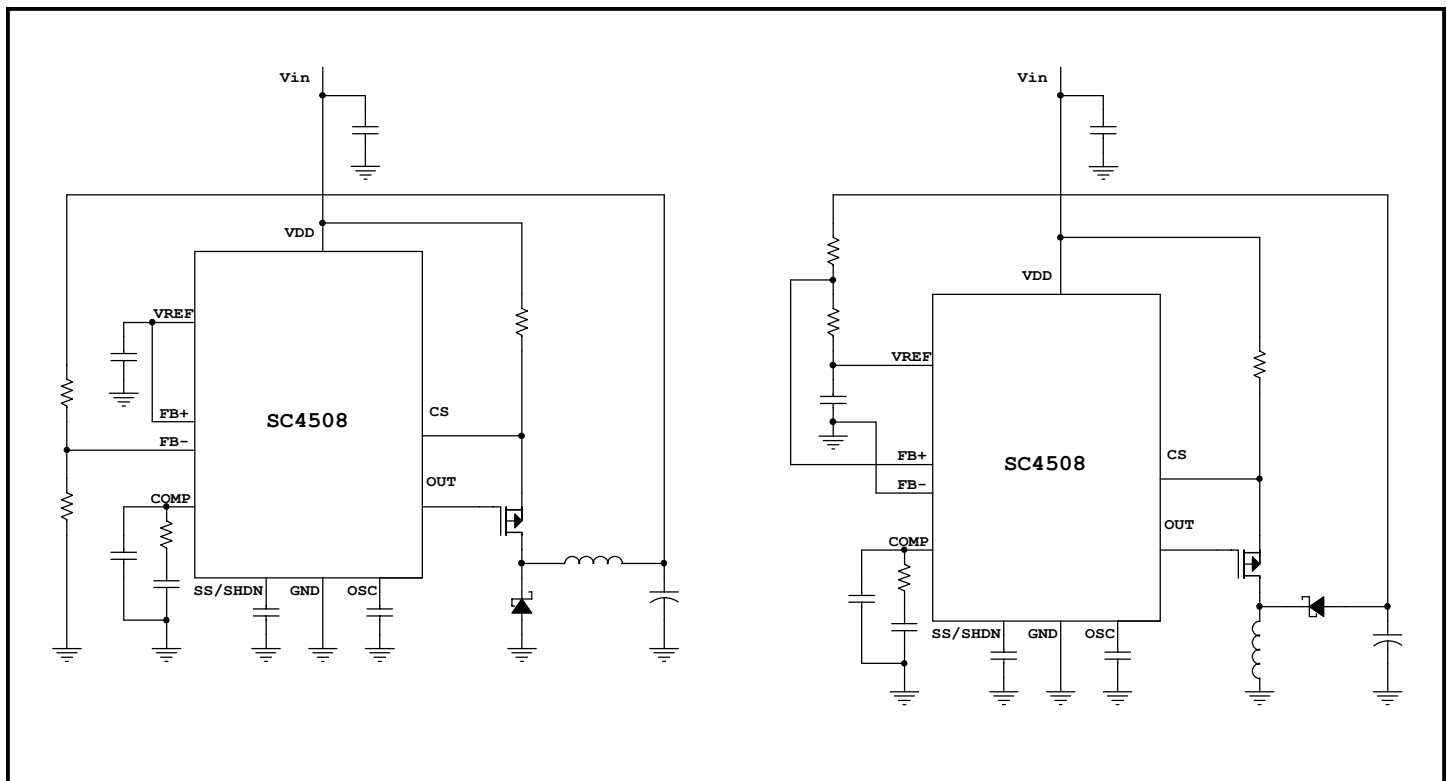

POWER MANAGEMENT
Absolute Maximum Rating

Exceeding the specifications below may result in permanent damage to the device, or device malfunction. Operation outside of the parameters specified in the Electrical Characteristics section is not implied. Exposure to Absolute Maximum rated conditions for extended periods of time may affect device reliability.

Parameter	Symbol	Maximum	Units
VDD to GND		-0.3 to 16	V
SS/SHDN to GND		3.2	V
FB+, FB-, COMP, OSC to GND		5	V
VREF Current		1	mA
OUT Source or Sink		250	mA
Thermal Resistance, Junction to Ambient	θ_{JA}	48	°C/W
Thermal Resistance, Junction to Case	θ_{JC}	3	°C/W
Storage Temperature Range	T_{STG}	-60 to +150	°C
Junction Temperature Range	T_J	-40 to +150	°C
Peak IR Reflow Temperature 10 - 40s	T_{PKG}	260	°C

Electrical Characteristics

Unless specified: $V_{DD} = 2.7V$ to $15V$, $T_A = T_J = -40^{\circ}C$ to $125^{\circ}C$

Parameter	Test Conditions	Min	Typ	Max	Unit
Power Supply					
Input Voltage Range		2.7		15	V
Quiescent Current	SHDN = low		200	500	μA
Operating Current	SHDN = high, No load		3		mA
Undervoltage Lockout					
Start Threshold	V_{DD} rising		2.5	2.55	V
UVLO Hysteresis			100		mV
Oscillator					
Frequency Range		100		1500	KHz
Frequency	$C_T = 300pF$	450	500	550	KHz
Charge Current			100		μA
Error Amplifier					
Feedback Input Voltage		0.75			V
Input Bias Current			100		nA
Transconductance			5		mS
Output Source or Sink Current		50	100		μA

POWER MANAGEMENT
Electrical Characteristics

 Unless specified: $V_{DD} = 2.7V$ to $15V$, $T_A = T_J = -40^{\circ}C$ to $125^{\circ}C$

Parameter	Test Conditions	Min	Typ	Max	Unit
PWM Comparator					
Delay to Output			50		ns
VREF Reference					
Output Voltage		1.231	1.25	1.269	V
Output Current				1	mA
Line Regulation	$V_{DD} = 2.7$ to $15V$, $I_{VREF} = 1mA$		4		mV
Load Regulation	$V_{DD} = 5V$, $I_{VREF} = 0$ to $1mA$		4		mV
Soft Start/Shutdown					
Charge Current			20		μA
Discharge Current			12		mA
SHDN Logic Hight Voltage		2			V
SHDN Logic Low Voltage				0.25	V
Current Limit					
Cycle by Cycle Threshold	$V_{DD} = 5V$	90	110	130	mV
Shutdown Threshold			0.16		V
Delay to Output			50		nS
Output					
Gate Drive On-Resistance(H)	$V_{DD} = 5V$, $I_{SOURCING} = 250mA$		20		Ohm
Gate Drive On-Resistance(L)	$V_{DD} = 5V$, $I_{SINK} = 250mA$		20		Ohm
Rise Time	$C_{OUT} = 200pF$		20		nS
Fall Time	$C_{OUT} = 200pF$		20		nS

Note:

(1) This device is ESD sensitive. Use of standard ESD handling precautions is required.

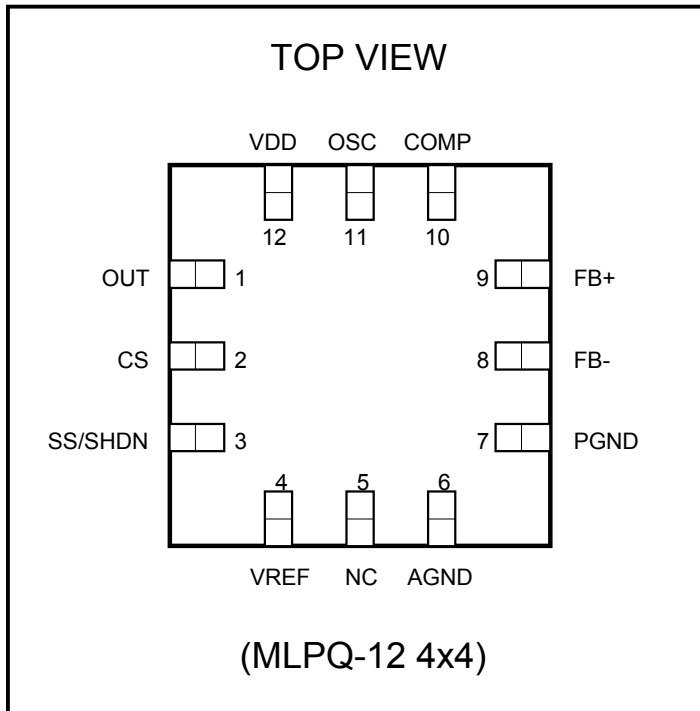
POWER MANAGEMENT
Pin Configuration

Ordering Information

DEVICE	PACKAGE	Temp. Range (T _j)
SC4508IMLTRT ⁽²⁾	MLPQ-12 ⁽¹⁾	-40°C to 150°C

Notes:

(1) Only available in tape and reel packaging. A reel contains 3000 devices.

(2) Lead free product. This product is fully WEEE and RoHS compliant.

Pin Descriptions

Pin #	Pin Name	Pin Function
1	OUT	Gate driver output for external P-MOSFET. OUT swings from VDD to PGND.
2	CS	Current sense input pin. Connect a current sense resistor between VDD and CS.
3	SS/SHDN	Soft start pin. Connects an external capacitor between this pin and AGND. The ramp up time is defined by the capacitor. The device goes into shutdown when VSS/SHDN is pulled below 0.25V.
4	VREF	1.25V reference output. VREF can source up to 1mA. Bypass with a 0.1uF ceramic capacitor from VREF to AGND.
5	NC	No connection.
6	AGND	Analog ground.
7	PGND	Power ground.
8	FB-	Error amplifier inverting input.
9	FB+	Error amplifier non-inverting input.
10	COMP	Compensation pin for the internal transconductance error amplifier. Connect loop compensation network from COMP to AGND.
11	OSC	Oscillator frequency set input. Connect a ceramic capacitor from OSC to AGND to set the internal oscillator frequency from 100KHz to 1.5MHz. Use equation $f = \frac{100\mu A}{C \cdot 0.65}$ to set the oscillator frequency. C is the capacitor from OSC to AGND.
12	VDD	Supply voltage. Bypass a 1uF ceramic capacitor from VDD to PGND.
-	THERMAL PAD	Pad for heatsinking purposes. Connect to ground plane using multiple vias. Not connected internally.

POWER MANAGEMENT

Block Diagram

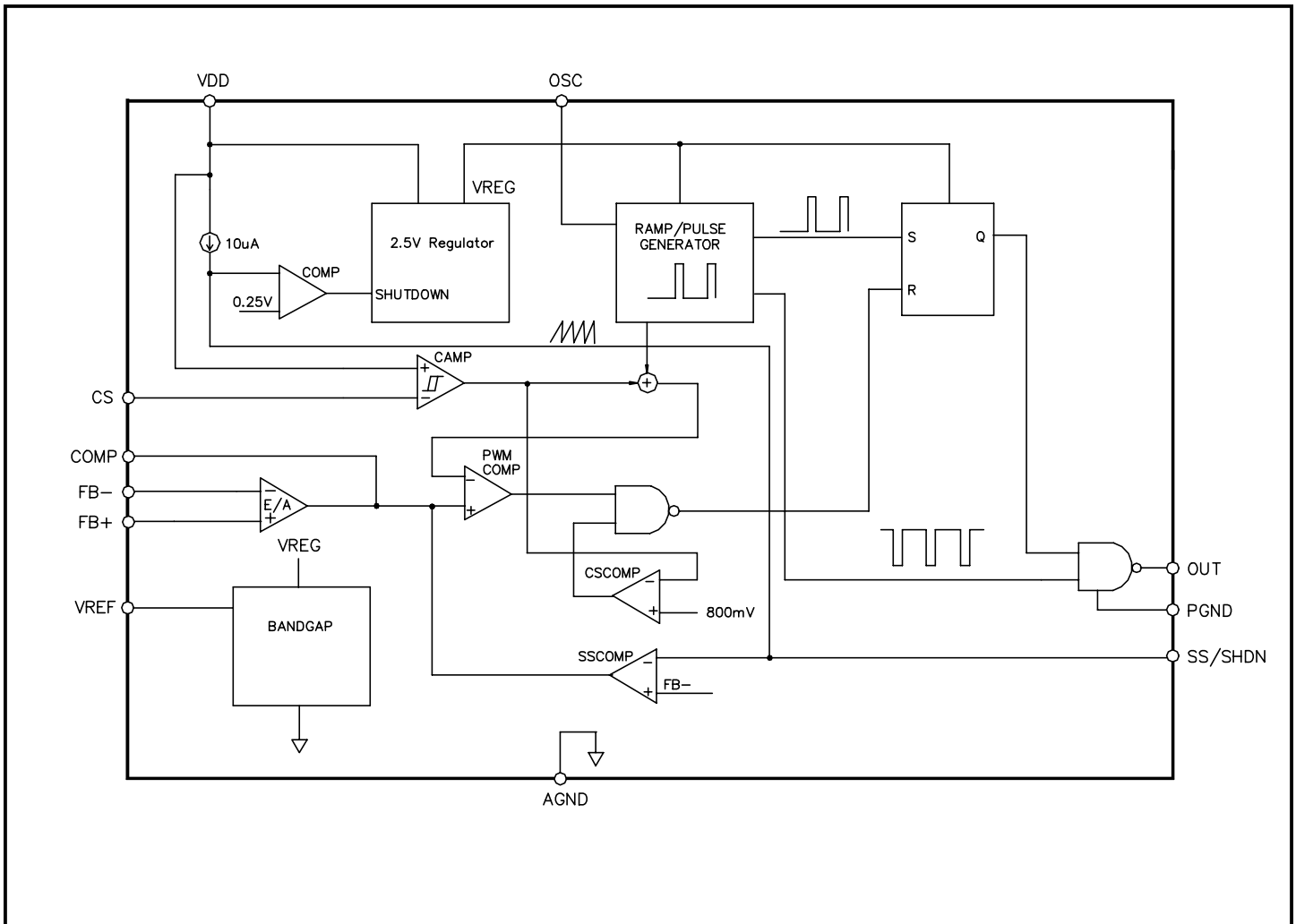

Marking Information

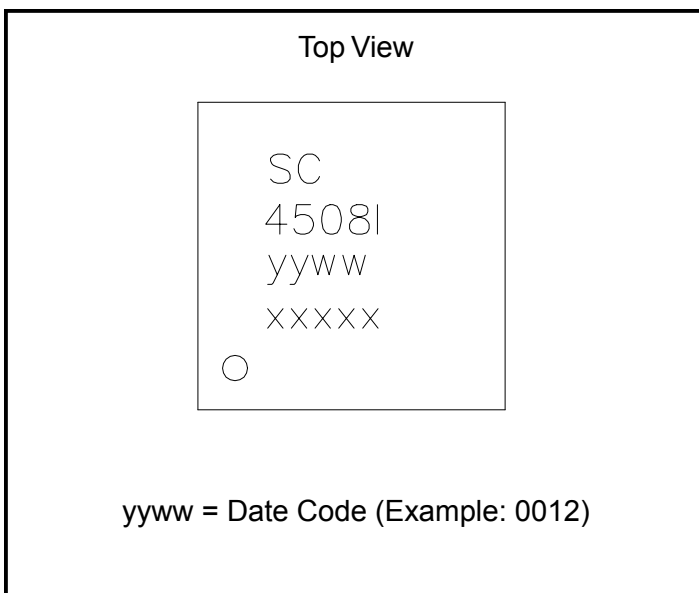

POWER MANAGEMENT
Application Information

The SC4508 is designed to control buck (step down) or buck-boost (inverting) converter with P-channel MOSFET as a switch using current mode, programmable switching frequency architecture. During steady state operation, the switch is turned on each cycle and turned off when the voltage across current sense resistor exceeds the voltage level at COMP pin set by voltage loop error amplifier. A fixed 0.5V artificial ramp is added internally to the sensed current signal for operations when duty-cycle is larger than 50%. In over load or output shortage condition, if the sensed current signal reaching typical 120mV, the switch is turned off immediately in the same cycle. If the sensed current signal further increases to typical 160mV, not only the switch is turned off but also the soft start capacitor is discharged by a internal MOSFET to ground then charging back to threshold 250mV during which the switch is held off. With the “hiccup” mode over current protection, the thermal stress is reduced in the faulty conditions.

Current Sense and Current Limit

The typical cycle-by-cycle current limit threshold in the current sense pin of the SC4508 is 120mV. The over current limit is assumed typical 120% of full load current. Then the current sense resistor can be calculated by the following equation:

$$R_s = \frac{120\text{mV}}{120\% \cdot I_L(\text{pk})}$$

$$I_L(\text{pk}) = I_o + \frac{1}{2} \frac{V_{IN} - V_o}{f_s \cdot L} \left(\frac{V_o + V_D}{V_{IN} + V_D} \right) \text{ for Buck}$$

$$I_L(\text{pk}) = I_o \frac{V_{IN} + |V_o| + V_D}{V_{IN}} + \frac{1}{2} \frac{V_{IN}}{f_s \cdot L} \left(\frac{|V_o| + V_D}{V_{IN} + |V_o| + V_D} \right)$$

for Buck – Boost

I_o - full load current

V_o - output voltage

V_{IN} - input voltage

V_D - diode forward voltage drop

f_s - switching frequency

L - inductor

Inductor Selection

A inductor is chosen based on the required output ripple current which is usually 20-30% of load current. The ripple current ΔI decreases with higher inductance and increases with higher input voltage V_{IN} or output voltage V_o .

$$L = \frac{V_{IN} - V_o}{f_s \cdot \Delta I_L} \left(\frac{V_o + V_D}{V_{IN} + V_D} \right) \text{ for Buck}$$

$$L = \frac{V_{IN}}{f_s \cdot \Delta I_L} \left(\frac{|V_o| + V_D}{V_{IN} + |V_o| + V_D} \right) \text{ for Buck-Boost}$$

Specify the maximum inductor current larger than $I_L(\text{pk})$ set by the current sense resistor R_s to avoid the inductor core saturation.

Input Capacitor C_{IN} and Output Capacitor C_{OUT} Selection

Both input and output capacitors need to be sized to handle the ripple current safely. Buck converters have high ripple current in the input side while buck-boost converters have high ripple current in the both input and output capacitors. Therefore, the RMS value of the current must be less than the high frequency ripple rating of the capacitors. In continuous mode operation,

$$I_{\text{RMS_INPUT_CAP}} \approx I_o \frac{\sqrt{V_o(V_{IN} - V_o)}}{V_{IN}} \text{ for Buck}$$

$$I_{\text{RMS_CAP}} \approx I_o \sqrt{\frac{V_o + V_D}{V_{IN}}} \text{ for Buck-Boost input and output capacitors.}$$

The C_{OUT} is selected for Buck converter is by required output^{OUT} ripple voltage and converter loop stability. The output ripple is determined by:

$$\Delta V_o \approx \Delta I_L \left(\text{ESR} + \frac{1}{8f_s C_{OUT}} \right)$$

where f is converted switching frequency, C_{OUT} is output capacitance and ΔI_L is inductor ripple current.

POWER MANAGEMENT
Application Information (Cont.)

In Buck converter, the worst case input RMS ripple current occurs at 50% duty cycle, or at $V_{IN} = 2V_{OUT}$. Under this condition, the input capacitors RMS ripple current is about half of the load current.

MOSFET Selection

The selection criteria for the power MOSFET is its operating junction temperature not exceeding the maximum junction temperature. Therefore, from a specified ambient temperature, the maximum junction to ambient temperature rise has to be determined, which is related to the MOSFET power dissipation or power loss. The power loss includes conduction loss and switching loss. The conduction loss is given by:

$$P_{ON} = \left(\frac{V_O + V_D}{V_{IN} + V_D} \right) I_O^2 R_{DS(ON)} \text{ for Buck}$$

$$P_{ON} = \left(\frac{V_{IN} + |V_O| + V_D}{V_{IN}} \right) (|V_O| + V_D) I_O^2 R_{DS(ON)} \text{ for Buck-Boost}$$

Freewheeling Diode Selection

The Schottky diode is recommended as freewheeling diode in the both Buck and Buck-Boost applications. The diode conducts during the off-time. The diode voltage and current ratings are selected based upon the peak reverse voltage, the peak current and average power dissipation.

$$V_{D(REV)} = V_{IN}, I_{D(PEAK)} = I_O + \frac{\Delta I_L}{2}, I_{D(AVG)} = I_O \frac{V_{IN} - V_O}{V_{IN} + V_D} \text{ for Buck}$$

$$V_{D(REV)} = V_{IN} + |V_O|, I_{D(PEAK)} = I_O \left(\frac{V_{IN} + |V_O| + V_D}{V_{IN}} \right) + \frac{\Delta I_L}{2}, I_{D(AVG)} = I_O$$

for Buck – Boost

The most stressful condition for the diode occurs when the output is shorted. Under this condition, due to the $V_{OUT} = 0$, the diode conducts at close to 100% duty cycle. Therefore, attention should be paid to the thermal condition when laying out a board.

LAYOUT GUIDELINES

Careful attention to layout requirements are necessary for successful implementation of the SC4508 PWM controller. High switching currents are present in the application and their effect on ground plane voltage differentials must be understood and minimized.

1). The high power parts of the circuit should be laid out first. A ground plane should be used, the number and position of ground plane interruptions should be such as to not unnecessarily compromise ground plane integrity. Isolated or semi-isolated areas of the ground plane may be deliberately introduced to constrain ground currents to particular areas, for example, the input capacitor and output capacitor ground.

2). The loop formed by the Input Capacitor(s) (Cin), the MOSFET and the Schottky diode or inductor must be kept as small as possible. This loop contains all the high current, fast transition switching. Connections should be as wide and as short as possible to minimize loop inductance

3). The connection between the junction of MOSFET, Schottky diode and the output inductor should be a wide trace or copper region. It should be as short as practical. Since this connection has fast voltage transitions, keeping this connection short will minimize EMI.

4) The Output Capacitor(s) (Cout) should be located as close to the load as possible, fast transient load currents are supplied by Cout only, and connections between Cout and the load must be short, wide copper areas to minimize inductance and resistance.

5) A separate analog ground plane connects to the SC4508 AGND pin. All analog grounding path including decoupling capacitors, feedback resistors, compensation components, and current-limit setting resistors should be connected to this plane.

POWER MANAGEMENT

Evaluation Board Schematic, Buck-Boost

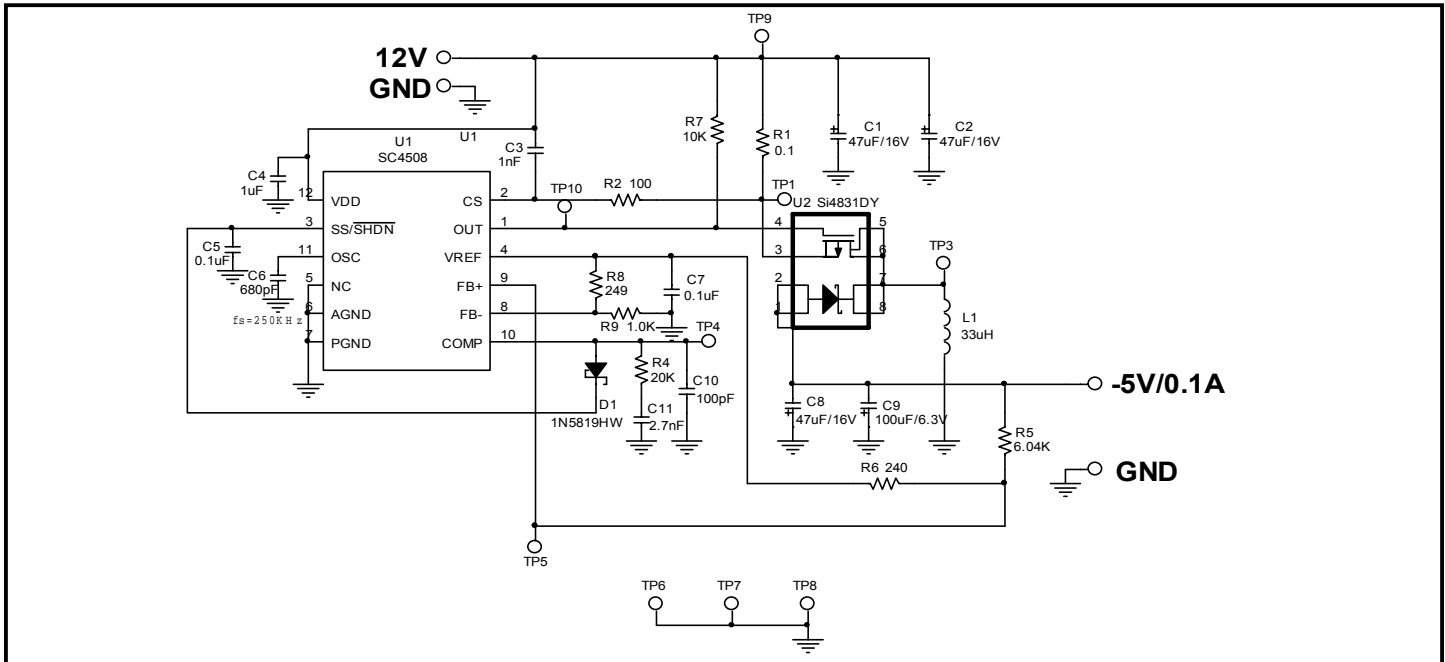

Bill of Materials

Item	Quantity	Reference	Part	Manufacturer
1	3	C1,C2,C8	47uF/16V	Sanyo P/N: 16TPB47M
2	1	C3	1nF	
3	1	C4	1uF	
4	2	C5, C7	0.1uF	
5	1	C6	680pF	
6	1	C9	100uF/6.3V	
7	1	C10	100pF	
8	1	C11	2.7nF	
9	1	D6	1N5819HW	
10	1	L1	3.3uH	
11	1	R1	0.1	
12	1	R2	100	
13	1	R4	20K	
14	1	R5	6.04K	
15	2	R6, R8	249	
16	1	R7	10K	
17	1	R9	1.0K	
19	1	U1	SC4508	Semtech Corp.
20	1	U2	Si4831DY	Vishay

POWER MANAGEMENT

Outline Drawing - MLPQ-12, 4 x 4

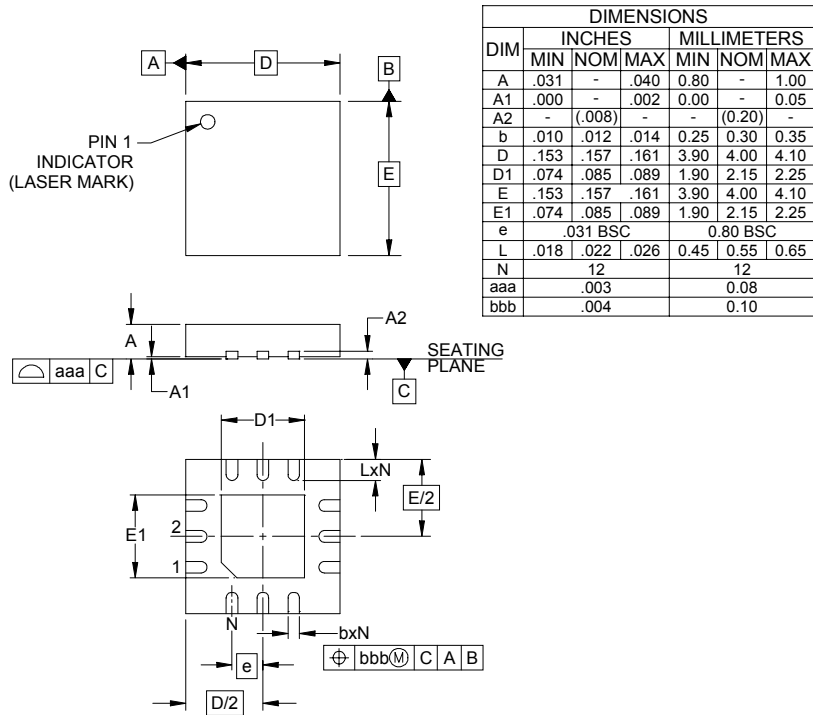

- NOTES:
1. CONTROLLING DIMENSIONS ARE IN MILLIMETERS (ANGLES IN DEGREES).
 2. COPLANARITY APPLIES TO THE EXPOSED PAD AS WELL AS THE TERMINALS.

Land Pattern - MLPQ-12, 4 x 4

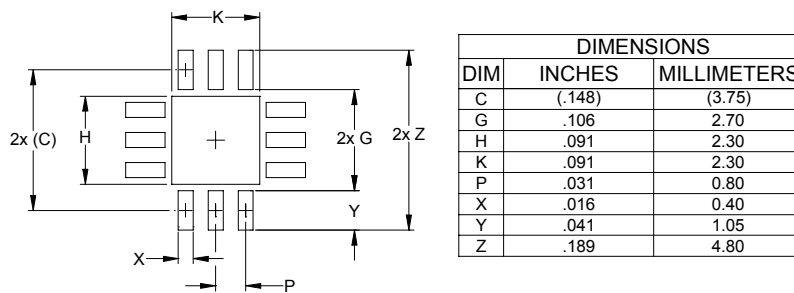

- NOTES:
1. THIS LAND PATTERN IS FOR REFERENCE PURPOSES ONLY. CONSULT YOUR MANUFACTURING GROUP TO ENSURE YOUR COMPANY'S MANUFACTURING GUIDELINES ARE MET.

Contact Information for Semtech International AG

Taiwan Branch Tel: 886-2-2748-3380
 Fax: 886-2-2748-3390

Korea Branch Tel: 82-2-527-4377
 Fax: 82-2-527-4376

Shanghai Office Tel: 86-21-6391-0830
 Fax: 86-21-6391-0831

Semtech Switzerland GmbH Tel: 81-3-6408-0950
Japan Branch Fax: 81-3-6408-0951

Semtech Limited (U.K.) Tel: 44-1794-527-600
 Fax: 44-1794-527-601

Semtech France SARL Tel: 33-(0)169-28-22-00
 Fax: 33-(0)169-28-12-98

Semtech Germany GmbH Tel: 49-(0)8161-140-123
 Fax: 49-(0)8161-140-124

Semtech International AG is a wholly-owned subsidiary of Semtech Corporation, which has its headquarters in the U.S.A.