

Very Low Input /Very Low Dropout 1 Amp Regulator With Enable

POWER MANAGEMENT

Features

- Input voltage as low as 1.5V
- 400mV dropout @ 1A
- Adjustable output from 0.5V
- Over current and over temperature protection
- Enable pin
- 10µA quiescent current in shutdown
- Low reverse leakage (output to input)
- Full industrial temperature range
- Pb Free, Halogen Free and WeEE/RoHS Compliant

Applications

- Telecom/Networking cards
- Motherboards/Peripheral cards
- Industrial Applications
- Wireless infrastructure
- Set top boxes
- Medical equipment
- Notebook computers
- Battery powered systems

Description

The SC4212 is a high performance positive voltage regulator designed for applications requiring very low input voltage and very low dropout voltage at up to 1 Ampere. It operates with a VIN as low as 1.5V, with output voltage programmable as low as 0.5V. The SC4212 features ultra low dropout, ideal for applications where VO_{UT} is very close to VIN. Additionally, the SC4212 has an enable pin to further reduce power dissipation while shutdown. The SC4212 provides excellent regulation over variations in line, load and temperature.

The SC4212 is available in a 3 x 3 MLPD-8 package. The output voltage can be set via external divider or to a fixed setting of 0.5V depending upon how the FB pin is configured.

Typical Application Circuit

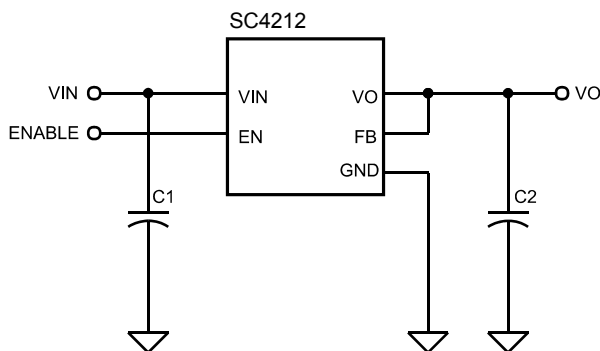

$$VO=0.5V$$

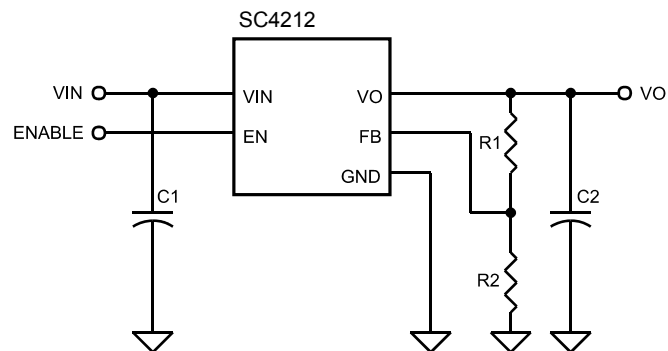

$$VO= \frac{0.5(R1+R2)}{R2} \text{ (Volts)}$$

Pin Configuration

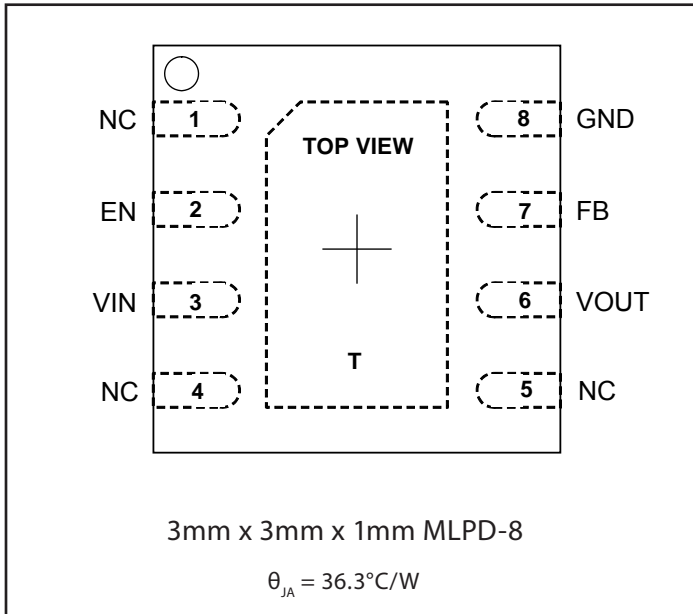

Ordering Information

Part Number	Package
SC4212MLTRT ⁽¹⁾⁽²⁾	3mm x 3mm x 1mm MLPD-8
SC4212EVB	Evaluation Board

Notes:

- (1) Only available in tape and reel packaging. A reel contains 3000 devices.
- (2) Device is Pb Free, Halogen Free, and WEEE/RoHS Compliant.

Marking Information



Marking for the 3 x 3mm MLPD 8ld Lead Package:

yyww = Datecode (Example : 0952)

xxxx = Semtech Lot No. (Example : E901)

Absolute Maximum Ratings

VIN to GND (V)	-0.3 to +7
EN, FB, VOUT (V)	-0.3 to VIN +0.3
ESD Rating ⁽²⁾ (kV)	3.5

Recommended Operating Conditions

Supply Input Voltage (V)	1.5 to 6.0
Output Current Range	8mA to 1A
Junction Temperature (°C)	-40 to +125

Exceeding the above specifications may result in permanent damage to the device or device malfunction. Operation outside of the parameters specified in the Electrical Characteristics section is not recommended.

NOTES:

(1) Calculated from package in still air, mounted to 3 x 4.5 (in), 4 layer FR4 PCB with thermal vias under the exposed pad per JESD51 standards.

(2) Tested according to JEDEC standard JESD22-A114-B.

Thermal Information

Thermal Resistance, Junction to Ambient ⁽¹⁾ (°C/W) ..	36.3
Thermal Resistance, Junction to Case (°C/W)	3.77
Operation Ambient Temperature Range (°C) ..	-40 to +85
Operation Junction Temperature Range (°C) .	-40 to +125
Storage Temperature (°C)	-65 to +150
Peak IR Reflow Temperature (10s to 30s)	+260

Electrical Characteristics

Unless specified otherwise: FB = VOUT, EN = VIN = 1.5V to 6V, I_{OUT} = 8mA to 1A, T_A = +25°C for Typ, -40 to +85 °C for Min and Max, T_J < 125°C.

Parameter	Symbol	Conditions	Min	Typ	Max	Units
Input Supply						
Input Supply Voltage	VIN		1.5		6	V
Quiescent Current	I _Q	VIN = 3.3V, I _{OUT} = 0A			3	mA
		VIN = 6V, EN = 0V			15	µA
Output						
Output Voltage ⁽¹⁾	VOUT	VIN = 3.3V, I _{OUT} = 10mA, T _A = 25°C	-2%	VOUT	+2%	V
		1.5V ≤ VIN ≤ 6V, I _{OUT} = 10mA	-3%		+3%	
Line Regulation ⁽¹⁾	REG _(LINE)	I _{OUT} = 10mA		0.20	0.40	%/V
Load Regulation ⁽¹⁾	REG _(LOAD)	I _{OUT} = 10mA to 1A		0.50	1.50	%/A
Minimum Load Current ⁽³⁾	I _{OUT}	VIN = VOUT + 0.5V			8	mA
Current Limit	I _{CL}		1.10	1.5		A
Dropout Voltage ⁽¹⁾⁽²⁾	V _{DO}	I _{OUT} = 500mA, T _A = 25°C		100	250	mV
		I _{OUT} = 500mA			300	
		I _{OUT} = 1A, T _A = 25°C		200	400	
		I _{OUT} = 1A			500	

Electrical Characteristics (continued)

Parameter	Symbol	Conditions	Min	Typ	Max	Units
Feedback						
Reference Voltage ⁽¹⁾	V_{REF}	$V_{IN} = 3.3V, FB = V_{OUT}, I_{OUT} = 10mA, T_A = 25^{\circ}C$	0.495	0.500	0.505	V
			0.490		0.510	
Feedback Pin Current	I_{FB}	$FB = V_{REF}$		80	200	nA
Enable						
Enable Input High Current	I_{EN}	$EN = 0V, V_{IN} = 3.3V$		1.5	10.0	μA
Enable Input Threshold	V_{IH}	$V_{IN} = 3.3V$	1.6			V
	V_{IL}	$V_{IN} = 3.3V$			0.5	
Over Temperature Protection						
High Trip Level	T_{OT}			160		$^{\circ}C$
Hysteresis	T_{OT_HYS}			10		$^{\circ}C$

Notes:

- (1) Low duty cycle pulse testing with Kelvin connections required.
- (2) $V_{DO} = V_{IN} - V_{OUT}$ when V_{OUT} decreases by 1.5% of its nominal output voltage when $V_{IN} = V_{OUT} + 0.8V$.
- (3) Required to guarantee stable regulation. Voltage set resistors R1 and R2 can be utilized to meet this requirement.

Typical Characteristics

Stability Curve, COUT = 10µF

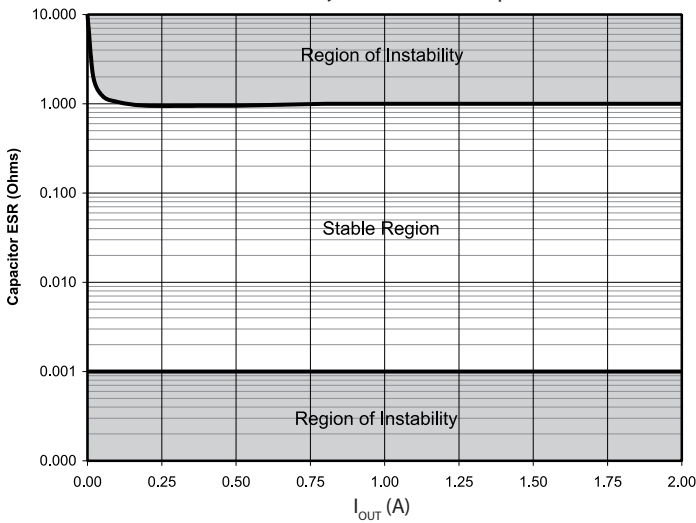

Stability Curve, COUT = 100µF

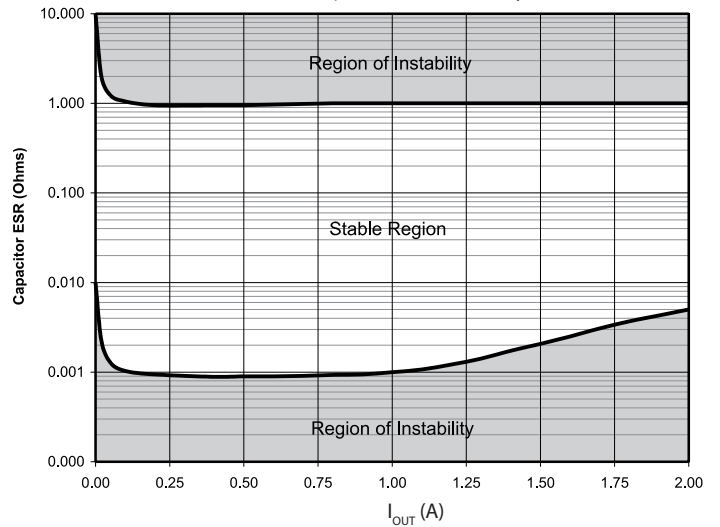

Typical Dropout Voltage at VIN = 1.5 V

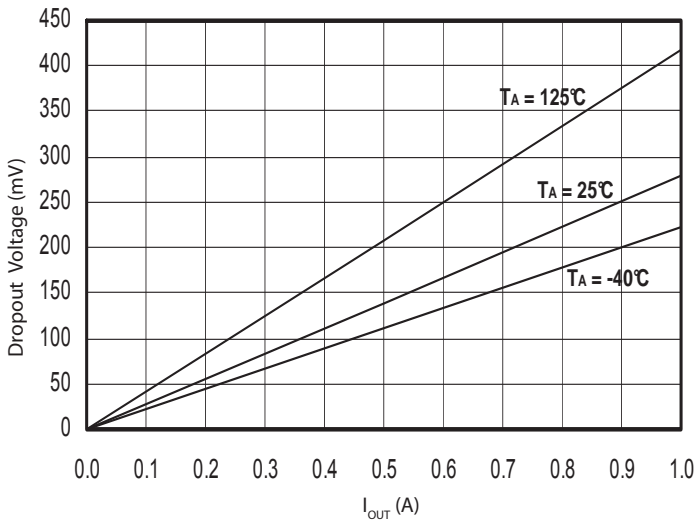

Typical Dropout Voltage at VIN = 5.0 V

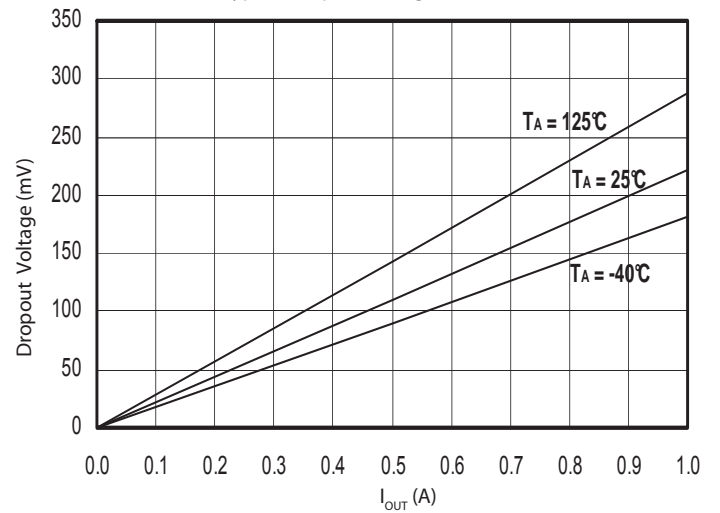

Reference Voltage vs. Junction Temperature

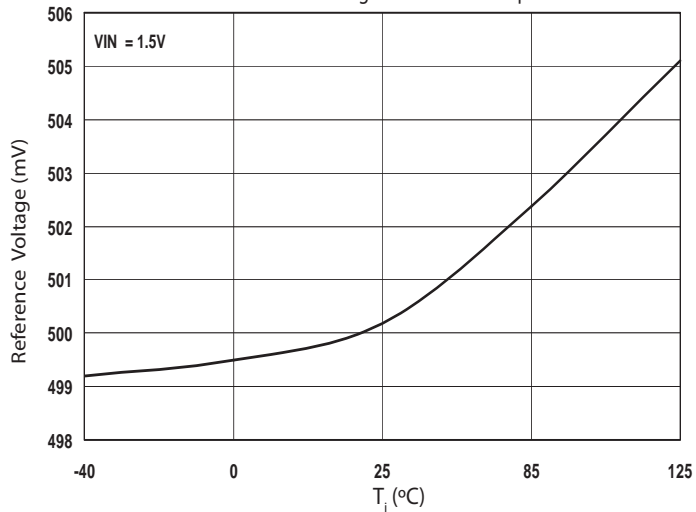

Reference Voltage vs. Junction Temperature

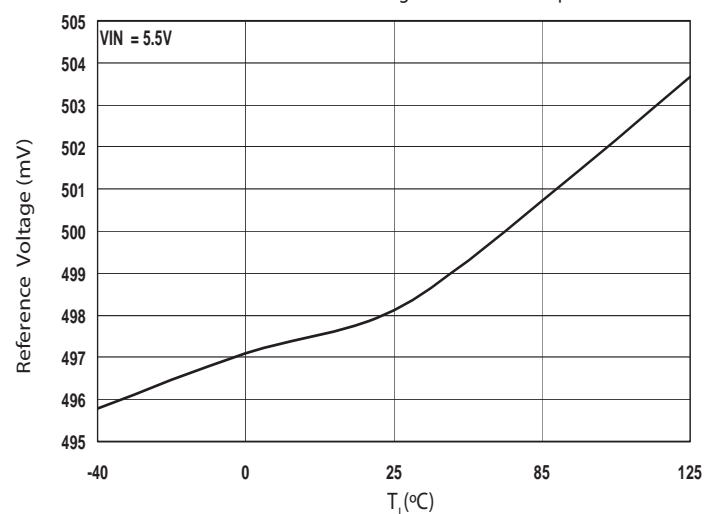

Pin Descriptions

Pin #	Pin Name	Pin Function
1,4,5	NC	No connect.
2	EN	Enable Input. Pulling this pin below 0.5V turns the regulator off, reducing the quiescent current to a fraction of its operating value. The device will be enabled if this pin is left open. Connect to VIN if the enable feature is not being used.
3	VIN	Input voltage pin. For regulation at full load, the input to this pin must be between (VOUT + 0.5V) and 6V. Minimum VIN = 1.5V. A large bulk capacitance should be placed close to this pin to ensure that the input supply does not sag below 1.5V. Also a minimum of 4.7μF ceramic capacitor should be placed directly at this pin.
6	VOUT	This pin is the power output of this device. A minimum 10μF capacitor should be placed directly at this pin.
7	FB	When this pin is connected to the VOUT pin, the output voltage will be set to 0.5V. If external feedback resistors are used, the output voltage will be determined by the resistor ratio (See Application Circuits on page1): $V_{OUT} = \frac{0.5 \cdot (R_1 + R_2)}{R_2} \cdot \text{Volts}$ R ₁ : The resistor connected from VOUT to FB. R ₂ : The resistor connected from FB to GND.
8	GND	Reference ground. The GND pin and the thermal pad must be connected together at the IC.
T	Thermal Pad	Thermal pad for heatsinking purposes. Not connected internally. Connect to ground plane using multiple vias.

Block Diagram

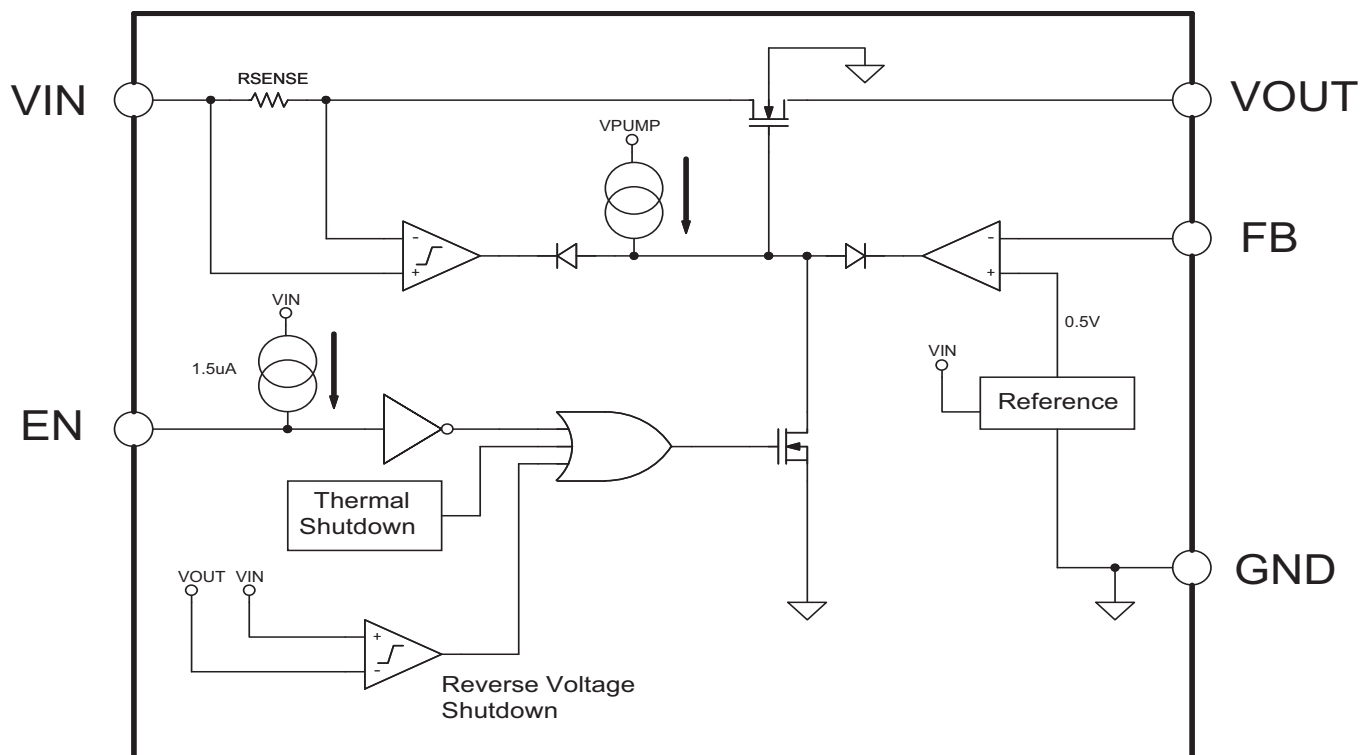

Applications Information

Introduction

The SC4212 is intended for applications where high current capability and very low dropout voltage are required. It provides a very simple, low cost solution that uses very little PCB real estate. Additional features include an enable pin to allow for a very low power consumption standby mode, and a fully adjustable output.

Component Selection

Input capacitor: A large bulk capacitance of $\geq 10\mu\text{F}$ should be placed close to the input supply pin of the SC4212 to ensure that V_{IN} does not sag below 1.5V. Also a minimum 4.7 μF ceramic capacitor is recommended to be placed directly next to the V_{IN} pin. This allows for the device being some distance from any bulk capacitance on the rail. Additionally, input droop due to load transients is reduced, improving load transient response. Additional capacitance may be added if required by the application.

Output capacitor: A minimum bulk capacitance of $\geq 10\mu\text{F}$, along with a 0.1 μF ceramic decoupling capacitor is recommended. Increasing the bulk capacitance will improve the overall transient response. The use of multiple lower value ceramic capacitors in parallel to achieve the desired bulk capacitance will not cause stability issues. Although designed for use with ceramic output capacitors, the SC4212 is extremely tolerant of output capacitor ESR values and thus will also work comfortably with tantalum output capacitors.

Noise immunity: In very electrically noisy environments, it is recommended that 0.1 μF ceramic capacitors be placed from V_{IN} to GND and V_{OUT} to GND as close to the device pins as possible.

External voltage selection resistors: The use of 1% resistors is recommended.

Enable: Pulling the EN pin below 0.5V turns the regulator off, reducing the quiescent current to a fraction of its operating value. A pull up resistor up to 400k Ω should be connected from the EN pin to the V_{IN} pin in application

where an input voltage of $< 1.9\text{V}$ is required. For applications with input voltages higher than 1.9V, the EN pin could be left open or connected to V_{IN} .

Thermal Considerations

The power dissipation in the SC4212 is approximately equal to the product of the output current and the input to output voltage differential:

$$P_{\text{O}} = (V_{\text{IN}} - V_{\text{OUT}}) \times I_{\text{OUT}}$$

The absolute worst-case dissipation is given by:

$$P_{\text{O(MAX)}} = V_{\text{IN(MAX)}} - V_{\text{OUT(MIN)}} \times I_{\text{OUT(MAX)}} + V_{\text{IN(MAX)}} \times I_{\text{Qt(MAX)}}$$

For a typical scenario, $V_{\text{IN}} = 3.3\text{V} \pm 5\%$, $V_{\text{OUT}} = 2.8\text{V}$ and $I_{\text{OUT}} = 1\text{A}$, therefore:

$$\begin{aligned} V_{\text{IN(MAX)}} &= 3.465\text{V}, \\ V_{\text{OUT(MIN)}} &= 2.744\text{V} \text{ and} \\ I_{\text{Q(MAX)}} &= 3\text{mA} \end{aligned}$$

$$\text{Thus } P_{\text{D(MAX)}} = 0.731\text{W}.$$

Using this figure, and assuming $T_{\text{A(MAX)}} = 70^\circ\text{C}$, we can calculate the maximum thermal impedance allowable to maintain $T_{\text{J}} \leq 125^\circ\text{C}$:

$$R_{\text{TH(J-A)(MAX)}} = \left(\frac{T_{\text{J(MAX)}} - T_{\text{A(MAX)}}}{P_{\text{O(MAX)}}} \right) = \left(\frac{125^\circ\text{C} - 85^\circ\text{C}}{0.722\text{W}} \right) = 76^\circ\text{C/W}$$

This should be achievable with the 3mm x 3mm MLPD-8 package using PCB copper area to aid in conducting the heat away, such as one square inch of copper connected to the ground pins of the device. Internal ground/power planes and air flow will also assist in removing heat. For higher ambient temperatures it may be necessary to use additional copper area.

Outline Drawing — 3mm x 3mm MLPD-8

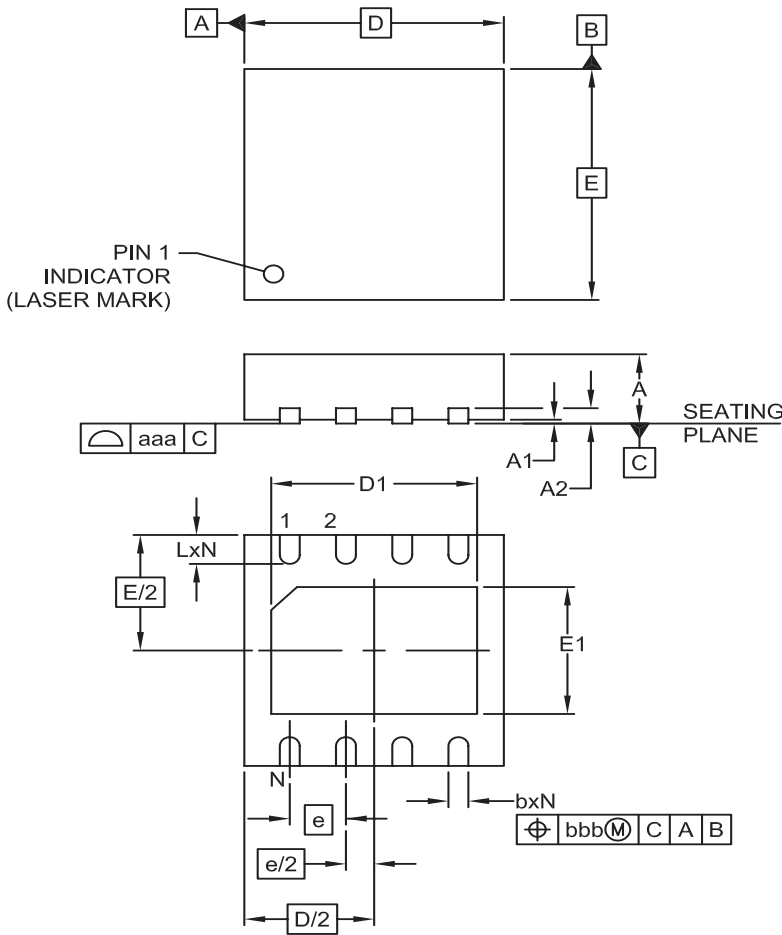

DIM	INCHES			MILLIMETERS		
	MIN	NOM	MAX	MIN	NOM	MAX
A	.031	.035	.039	0.80	0.90	1.00
A1	.000	.001	.002	0.00	0.02	0.05
A2	-	(.008)	-	-	(0.20)	-
b	.010	.012	.014	0.25	0.30	0.35
D	.114	.118	.122	2.90	3.00	3.10
D1	.085	-	.098	2.15	-	2.48
E	.114	.118	.122	2.90	3.00	3.10
E1	.053	-	.069	1.35	-	1.75
e	.026 BSC			0.65 BSC		
L	.012	.016	.020	0.30	0.40	0.50
N	8			8		
aaa	.003			0.08		
bbb	.004			0.10		

NOTES:

1. CONTROLLING DIMENSIONS ARE IN MILLIMETERS (ANGLES IN DEGREES).
2. COPLANARITY APPLIES TO THE EXPOSED PAD AS WELL AS TERMINALS.

Land Pattern — 3mm x 3mm MLPD-8

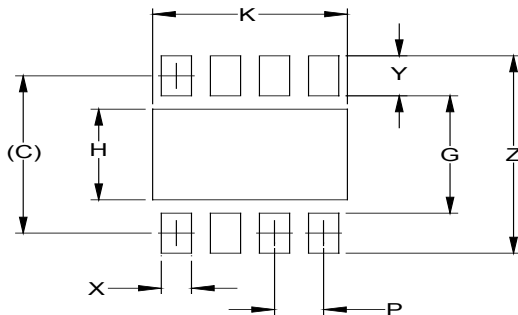

DIM	DIMENSIONS	
	INCHES	MILLIMETERS
C	(.116)	(2.95)
G	.087	2.20
H	.067	1.70
K	.102	2.58
P	.026	0.65
X	.016	0.40
Y	.030	0.75
Z	.146	3.70

NOTES:

1. CONTROLLING DIMENSIONS ARE IN MILLIMETERS (ANGLES IN DEGREES).
2. THIS LAND PATTERN IS FOR REFERENCE PURPOSES ONLY. CONSULT YOUR MANUFACTURING GROUP TO ENSURE YOUR COMPANY'S MANUFACTURING GUIDELINES ARE MET.
3. THERMAL VIAS IN THE LAND PATTERN OF THE EXPOSED PAD SHALL BE CONNECTED TO A SYSTEM GROUND PLANE. FAILURE TO DO SO MAY COMPROMISE THE THERMAL AND/OR FUNCTIONAL PERFORMANCE OF THE DEVICE.

© Semtech 2011

All rights reserved. Reproduction in whole or in part is prohibited without the prior written consent of the copyright owner. The information presented in this document does not form part of any quotation or contract, is believed to be accurate and reliable and may be changed without notice. No liability will be accepted by the publisher for any consequence of its use. Publication thereof does not convey nor imply any license under patent or other industrial or intellectual property rights. Semtech assumes no responsibility or liability whatsoever for any failure or unexpected operation resulting from misuse, neglect improper installation, repair or improper handling or unusual physical or electrical stress including, but not limited to, exposure to parameters beyond the specified maximum ratings or operation outside the specified range.

SEMTECH PRODUCTS ARE NOT DESIGNED, INTENDED, AUTHORIZED OR WARRANTED TO BE SUITABLE FOR USE IN LIFE-SUPPORT APPLICATIONS, DEVICES OR SYSTEMS OR OTHER CRITICAL APPLICATIONS. INCLUSION OF SEMTECH PRODUCTS IN SUCH APPLICATIONS IS UNDERSTOOD TO BE UNDERTAKEN SOLELY AT THE CUSTOMER'S OWN RISK. Should a customer purchase or use Semtech products for any such unauthorized application, the customer shall indemnify and hold Semtech and its officers, employees, subsidiaries, affiliates, and distributors harmless against all claims, costs damages and attorney fees which could arise.

Contact Information

Taiwan	Tel: 886-2-2748-3380 Fax: 886-2-2748-3390	Switzerland	Tel: 41-32-729-4000 Fax: 41-32-729-4001
Korea	Tel: 82-2-527-4377 Fax: 82-2-527-4376	United Kingdom	Tel: 44-1794-527-600 Fax: 44-1794-527-601
Shanghai	Tel: 86-21-6391-0830 Fax: 86-21-6391-0831	France	Tel: 33-(0)169-28-22-00 Fax: 33-(0)169-28-12-98
Japan	Tel: 81-3-6408-0950 Fax: 81-3-6408-0951	Germany	Tel: 49-(0)8161-140-123 Fax: 49-(0)8161-140-124