

POWER MANAGEMENT

Description

The SC411 is a constant on-time synchronous buck PWM controller in a space-saving MLPQ package intended for use in notebook computers and other battery operated portable devices. Features include high efficiency and a fast dynamic response with no minimum on-time. The excellent transient response means that SC411 based solutions will require less output capacitance than competing fixed frequency converters.

The switching frequency is constant until a step-in load or line voltage occurs. During this time the pulse density and frequency will increase or decrease to counter the change in output or input voltage. After the transient event, the controller frequency will return to steady-state operation. At light loads, Powersave Mode enables the SC411 to skip PWM pulses for better efficiency.

The output voltage can be adjusted from 0.5V to VCCA. A frequency setting resistor sets the on-time for the controller. The integrated gate drivers feature adaptive shoot-through protection and soft-switching. Additional features include cycle-by-cycle current limit, digital soft-start, over-voltage and under-voltage protection, a Power Good output and soft discharge upon shutdown.

Features

- ◆ Constant on-time for fast dynamic response
- ◆ Programmable VOUT range = 0.5 – VCCA
- ◆ VBAT range = 1.8V – 25V
- ◆ DC current sense using low-side RDS(ON) Sensing or sense resistor
- ◆ Resistor programmable frequency
- ◆ Cycle-by-cycle current limit
- ◆ Digital soft-start
- ◆ Powersave option
- ◆ Over-voltage/under-voltage fault protection
- ◆ 10µA typical shutdown current
- ◆ Low quiescent power dissipation
- ◆ Power good indicator
- ◆ 1.2% reference
- ◆ Integrated gate drivers with soft switching
- ◆ Enable pin
- ◆ 16 pin MLPQ (4mm x 4mm)
- ◆ Output soft discharge upon shutdown

Applications

- ◆ Notebook Computers
- ◆ CPU/IO Supplies
- ◆ Handheld Terminals and PDAs
- ◆ LCD Monitors
- ◆ Network Power Supplies

Typical Application Circuit

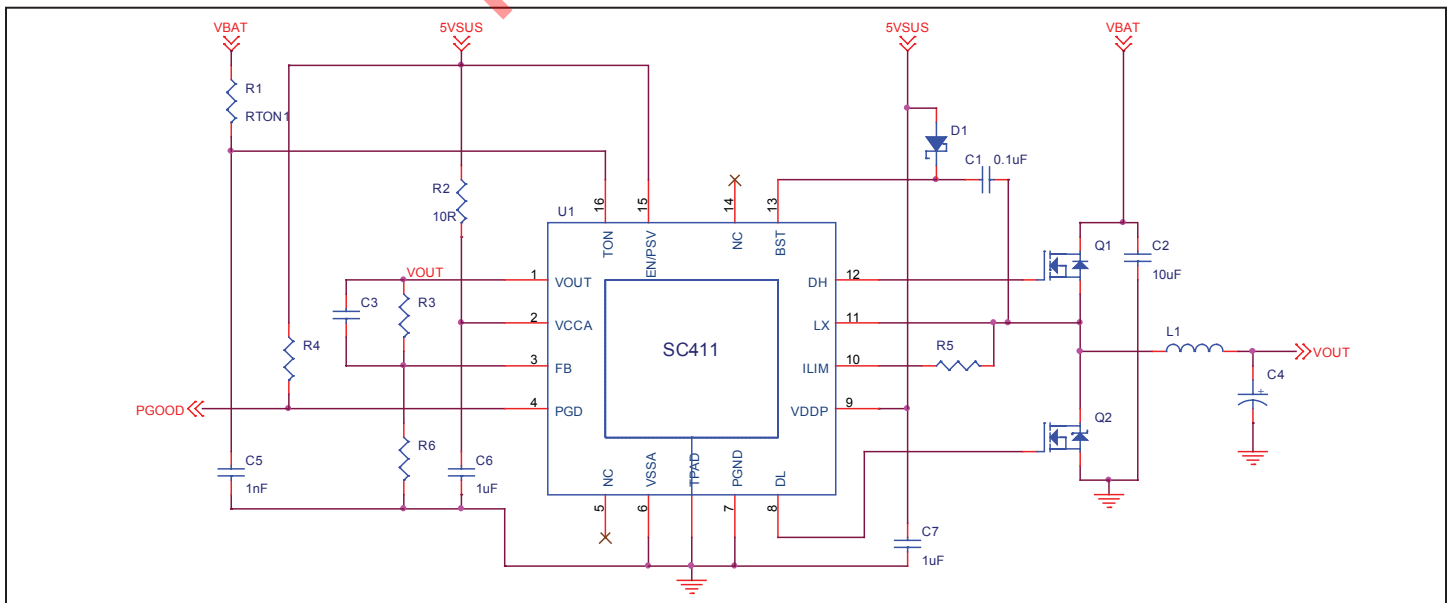

POWER MANAGEMENT

Absolute Maximum Ratings⁽¹⁾

Exceeding the specifications below may result in permanent damage to the device or device malfunction. Operation outside of the parameters specified in the Electrical Characteristics section is not implied. Exposure to Absolute Maximum rated conditions for extended periods of time may affect device reliability.

Parameter	Symbol	Maximum	Units
TON to VSSA		-0.3 to +25.0	V
DH, BST to PGND		-0.3 to +30.0	V
LX to PGND		-2.0 to +25.0	V
PGND to VSSA		-0.3 to +0.3	V
BST to LX		-0.3 to +6.0	V
DL, ILIM, VDDP to PGND		-0.3 to +6.0	V
EN/PSV, FB, PGD, VCCA, VOUT to VSSA		-0.3 to +6.0	V
VCCA to EN/PSV, FB, PGD, VOUT		-0.3 to +6.0	V
Thermal Resistance Junction to Ambient ⁽²⁾	θ_{JA}	31	°C/W
Operating Junction Temperature Range	T_J	-40 to +125	°C
Storage Temperature Range	T_{STG}	-65 to +150	°C
IR Reflow (Soldering) 10s to 30s	T_{PKG}	260	°C

Notes:

- 1) This device is ESD sensitive. Use of standard ESD handling precautions is required.
- 2) Calculated from package in still air, mounted to 3" to 4.5", 4 layer FR4 PCB with thermal vias under the exposed pad per JESD51 standards.

Electrical Characteristics

Test Conditions: $V_{BAT} = 15V$, $EN/PSV = 5V$, $VCCA = VDDP = 5V$, $V_{OUT} = 1.25V$, $R_{TON} = 1M\Omega$.

Parameter	Conditions	25°C			-40°C to 125°C		Units
		Min	Typ	Max	Min	Max	
Input Supplies							
VCCA			5.0		4.5	5.5	V
VDDP			5.0		4.5	5.5	V
VBAT Voltage	Off-time > 800ns	1.8		25			V
VDDP Operating Current	FB > regulation point, $I_{LOAD} = 0A$		70			150	μA
VCCA Operating Current	FB > regulation point, $I_{LOAD} = 0A$		700			1100	μA

POWER MANAGEMENT
Electrical Characteristics (Cont.)

Parameter	Conditions	25°C			-40°C to 125°C		Units
		Min	Typ	Max	Min	Max	
Input Supplies (Cont.)							
TON Operating Current	$R_{TON} = 1M$		15				μA
Shutdown Current	EN/PSV = 0V		-5		-10		μA
	VCCA		5		10		μA
	VDDP, TON		0		1		μA
Controller							
Error Comparator Threshold (FB Turn-on Threshold) ⁽¹⁾	VCCA = 4.5V to 5.5V Includes variations of internal x3 gain stage, comparator, and 1.5V REF		0.500		-1.2%	+1.2%	V
Output Voltage Range					0.5	VCCA	V
On-Time, $V_{BAT} = 2.5V$	$R_{TON} = 1M\Omega$		1761		1409	2113	ns
	$R_{TON} = 500k\Omega$		936		749	1123	
Minimum Off-Time			400			550	ns
VOUT Input Resistance			500				k Ω
VOUT Shutdown Discharge Resistance	EN/PSV = GND		22				Ω
FB Input Bias Current					-1.0	+1.0	μA
Over-Current Sensing							
ILIM Source Current	DL high		10		9	11	μA
Current Comparator Offset	PGND - ILIM				-10	10	mV
PSAVE							
Zero-Crossing Threshold	(PGND - LX), EN/PSV = 5V		5				mV
Fault Protection							

POWER MANAGEMENT

Electrical Characteristics (Cont.)

Parameter	Conditions	25°C			-40°C to 125°C		Units
		Min	Typ	Max	Min	Max	
Current Limit (Positive) ⁽²⁾	(PGND - LX), R _{ILIM} = 5kΩ		50		35	65	mV
	(PGND - LX), R _{ILIM} = 10kΩ		100		80	120	mV
	(PGND - LX), R _{ILIM} = 20kΩ		200		170	230	mV
Fault Protection (Cont.)							
Current Limit (Negative)	(PGND - LX)		-125		-160	-90	mV
Output Under-Voltage Fault	With respect to internal ref.		-30		-40	-25	%
Output Over-Voltage Fault	With respect to internal ref.		+16		+12	+20	%
Over-Voltage Fault Delay	FB forced above OV Threshold		5				μs
PGD Low Output Voltage	Sink 1mA					0.4	V
PGD Leakage Current	FB in regulation, PGD = 5V					1	μA
PGD UV Threshold	With respect to internal ref.		-10		-12	-8	%
PGD Fault Delay	FB forced outside PGD window		5				μs
VCCA Under-Voltage Threshold	Falling (100mV Hysteresis)		4.0		3.7	4.3	V
Over-Temperature Lockout	10°C Hysteresis		165				°C
Inputs/Outputs							
Logic Input Low Voltage	EN/PSV Low					1.2	V
Logic Input High Voltage	EN High, PSV Low (Floating)		2.0				V
Logic Input High Voltage	EN/PSV High				3.1		V
EN/PSV Input Resistance	R Pullup to VCCA		1.5				MΩ
	R Pulldown to VSSA		1.0				

POWER MANAGEMENT

Electrical Characteristics (Cont.)

Parameter	Conditions	25°C			-40°C to 125°C		Units
		Min	Typ	Max	Min	Max	
Soft-Start							
Soft-Start Ramp Time	EN/PSV High to PGD High		440				clks ⁽³⁾
Under-Voltage Blank Time	EN/PSV High to UV High		440				clks ⁽³⁾
Gate Drivers							
Shoot-Through Delay ⁽⁴⁾	DH or DL Rising		30				ns
DL Pull-Down Resistance	DL Low		0.80			1.75	Ω
DL Sink Current	DL = 2.5V		3.1				A
DL Pull-Up Resistance	DL High		2			4	Ω
DL Source Current	DL = 2.5V		1.3				A

Notes:

- 1) When the inductor is in continuous and discontinuous conduction mode, the output voltage will have a DC regulation level higher than the error-comparator threshold by 50% of the ripple voltage.
- 2) Using a current sense resistor, this measurement relates to PGND minus the voltage of the source on the low-side MOSFET. These values guaranteed by the ILIM Source Current and Current Comparator Offset tests.
- 3) clks = Switching cycles.
- 4) Guaranteed by design. See Shoot-Through Delay Timing Diagram on Page 8.
- 5) Semtech's SmartDriver™ FET drive first pulls DH high with a pull-up resistance of 10Ω (typ) until LX = 1.5V (typ). At this point, an additional pull-up device is activated, reducing the resistance to 2Ω (typ). This negates the need for an external gate or boost resistor.

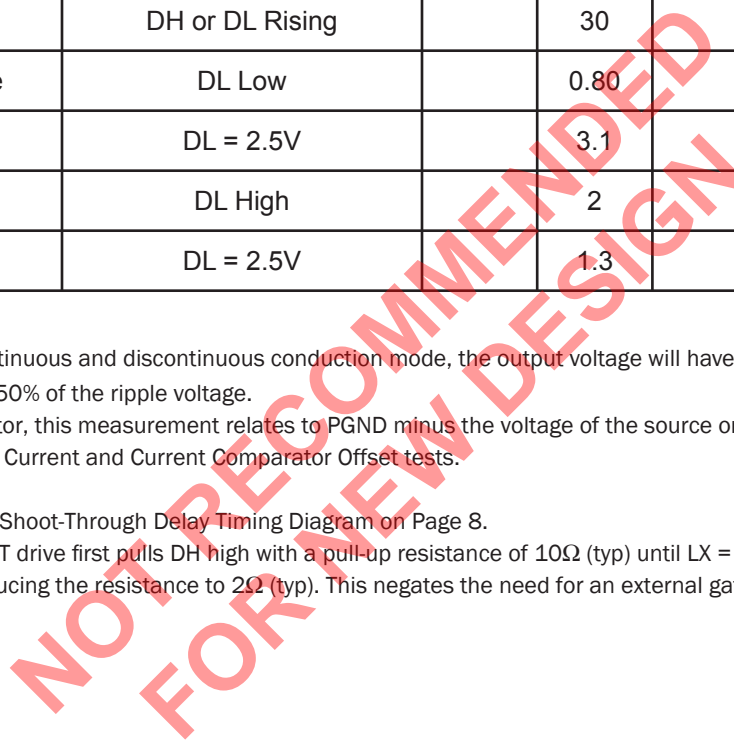

POWER MANAGEMENT

Block Diagram

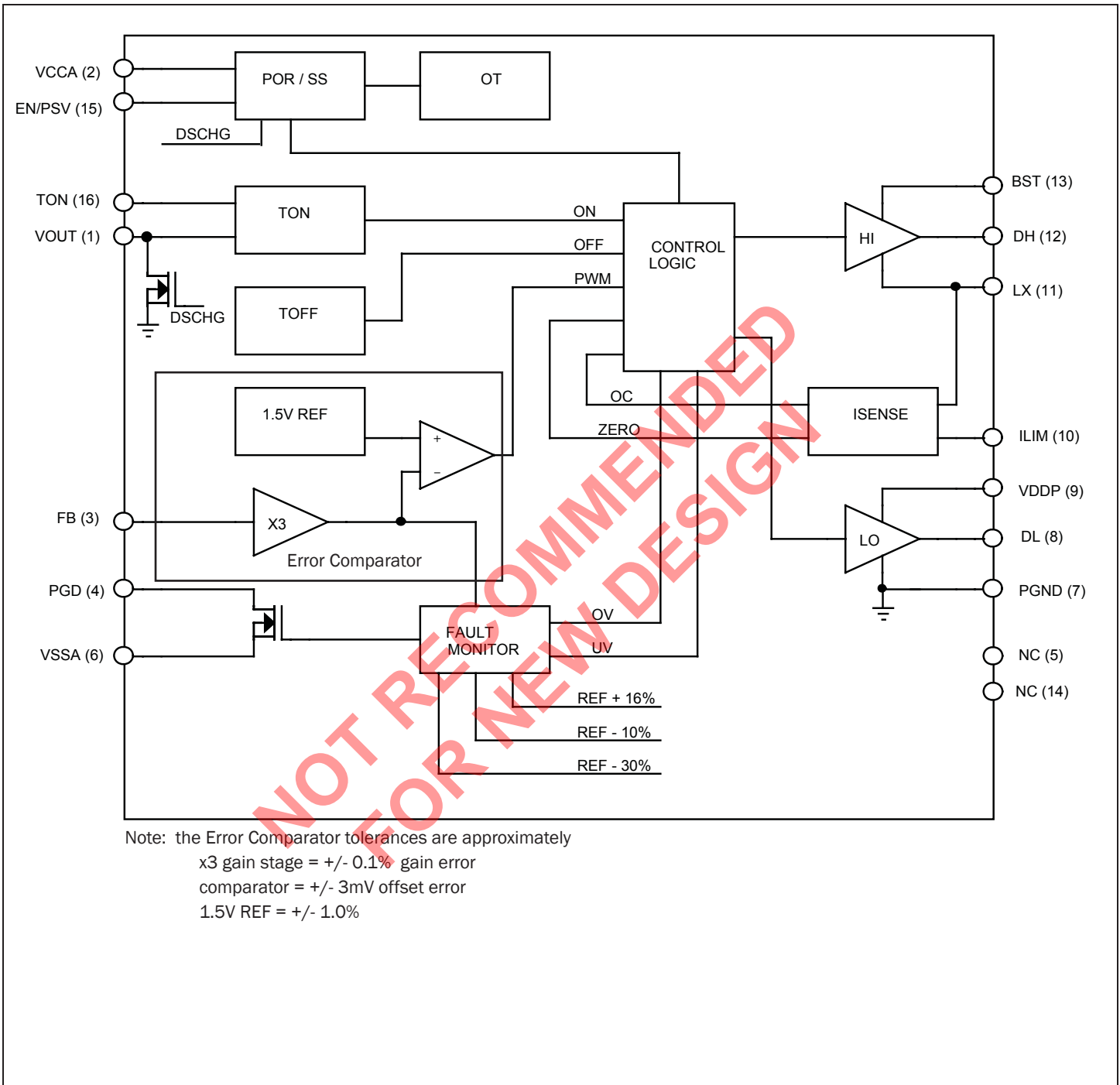

POWER MANAGEMENT

Pin Configuration

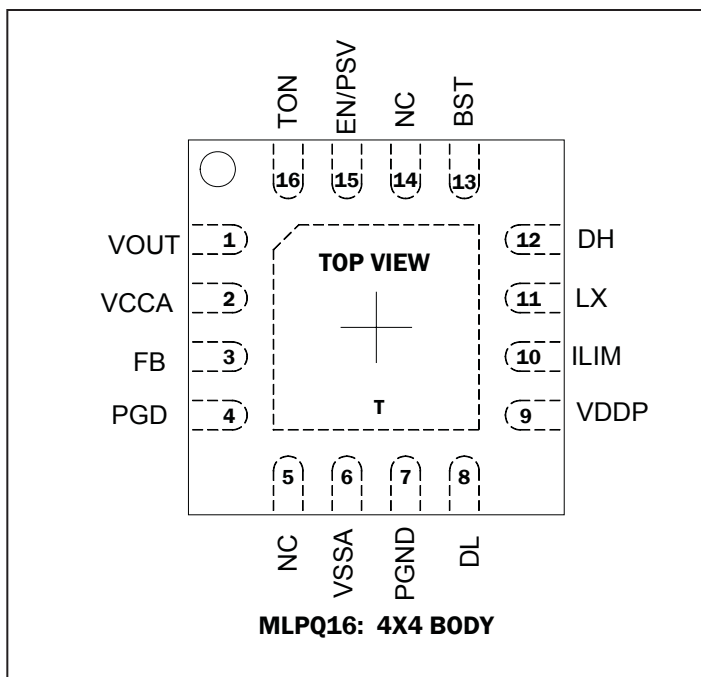

Ordering Information

Device	Package ⁽¹⁾
SC411MLTRT ⁽²⁾	MLPQ-16
SC411EVB	Evaluation Board

Notes:

1) Only available in tape and reel packaging. A reel contains 3000 devices.

(2) Lead free product. This product is fully WEEE, RoHS and J-STD-020B compliant.

Pin Descriptions

Pin #	Pin Name	Pin Function
1	VOUT	Output voltage sense input. Connect to the output at the load.
2	VCCA	Supply voltage input for the analog supply. Use a 10Ω /1μF RC filter from 5VSUS to VSSA.
3	FB	Feedback input. Connect to a resistor divider located at the IC from VOUT to VSSA to set the output voltage from 0.5V to VCCA.
4	PGD	Power Good open drain NMOS output. Goes high after a fixed clock cycle delay (440 cycles) following power up.
5	NC	Not Connected.
6	VSSA	Ground reference for analog circuitry. Connect directly to thermal pad.
7	PGND	Power ground. Connect directly to thermal pad.
8	DL	Gate drive output for the low side MOSFET switch.
9	VDDP	+5V supply voltage input for the gate drivers. Decouple this pin with a 1μF ceramic capacitor to PGND.
10	ILIM	Current limit input. Connect to drain of low-side MOSFET for RDS(on) sensing or the source for resistor sensing through a threshold sensing resistor.
11	LX	Phase node (junction of top and bottom MOSFETs and the output inductor) connection.

POWER MANAGEMENT

Pin Descriptions (Cont.)

12	DH	Gate drive output for the high side MOSFET switch.
13	BST	Boost capacitor connection for the high side gate drive.
14	NC	Not connected.
15	EN/PSV	Enable/Power Save input. Pull down to VSSA to shut down VOUT and discharge it through 22Ω (nom.). Pull up to enable VOUT and activate PSAVE mode. Float to enable VOUT activate continuous conduction mode (CCM). If floated, bypass to VSSA with a 10nF ceramic capacitor.
16	TON	This pin is used to sense VBAT through a pullup resistor, RTON, and to set the top MOSFET on-time. Bypass this pin with a 1nF ceramic capacitor to VSSA.
-	Thermal Pad	Pad for heatsinking purposes. Connect to ground plane using multiple vias. Not connected internally.

Shoot-Through Delay Timing Diagram

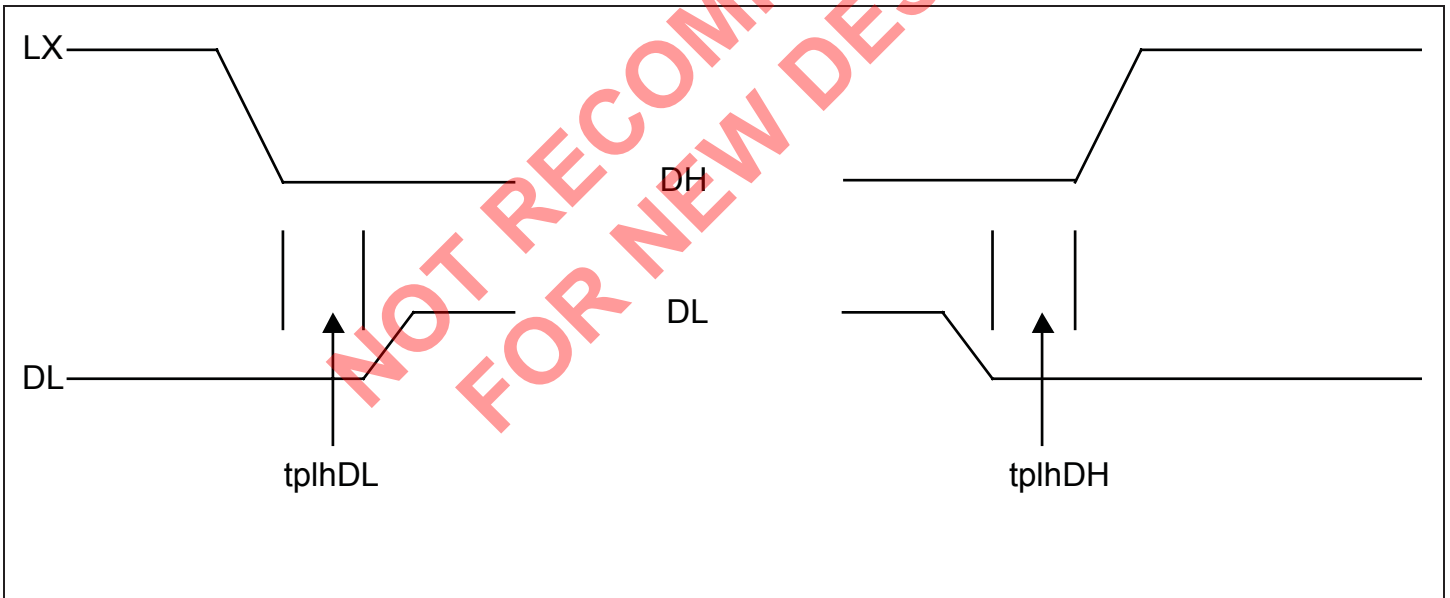

POWER MANAGEMENT

Application Information

+5V Bias Supplies

The SC411 requires an external +5V bias supply in addition to the battery. If stand-alone capability is required, the +5V supply can be generated with an external linear regulator such as the Semtech LP2951.

For optimal operation, the controller has its own ground reference, VSSA, which should be tied along with PGND directly to the thermal pad under the part, which in turn should connect to the ground plane using multiple vias. All external components referenced to VSSA in the Typical Application Circuit on Page 1 located near their respective pins. Supply decoupling capacitors should be located adjacent to their respective pins. A 10Ω resistor should be used to decouple VCCA from the main VDDP supply. All ground connections are connected directly to the ground plane as mentioned above. VSSA and PGND should be starred at the thermal pad. The VDDP input provides power to the upper and lower gate drivers; a decoupling capacitor is required. No series resistor between VDDP and 5V is required. See Layout Guidelines on page 17 for more details.

Pseudo-Fixed Frequency Constant On-Time PWM Controller

The PWM control architecture consists of a constant on-time, pseudo fixed frequency PWM controller (Block Diagram, Page 6). The output ripple voltage developed across the output filter capacitor's ESR provides the PWM ramp signal eliminating the need for a current sense resistor. The high-side switch on-time is determined by a one-shot whose period is directly proportional to output voltage and inversely proportional to input voltage. A second one-shot sets the minimum off-time which is typically 400ns.

On-Time One-Shot (t_{ON})

The on-time one-shot comparator has two inputs. One input looks at the output voltage, while the other input samples the input voltage and converts it to a current. This input voltage-proportional current is used to charge an internal on-time capacitor. The on-time is the time required for the voltage on this capacitor to charge from zero volts to VOUT, thereby making the on-time of the high-side switch directly proportional to output voltage and inversely proportional to input voltage. This implementation results

in a nearly constant switching frequency without the need for a clock generator.

For VOUT < 3.3V:

$$t_{ON} = 3.3 \times 10^{-12} \cdot (R_{TON} + 37 \times 10^3) \cdot \left(\frac{V_{OUT}}{V_{BAT}} \right) + 50ns$$

For 3.3V ≤ VOUT ≤ 5V:

$$t_{ON} = 0.85 \cdot 3.3 \times 10^{-12} \cdot (R_{TON} + 37 \times 10^3) \cdot \left(\frac{V_{OUT}}{V_{BAT}} \right) + 50ns$$

R_{TON} is a resistor connected from the input supply (VBAT) to the TON pin. Due to the high impedance of this resistor, the TON pin should always be bypassed to VSSA using a 1nF ceramic capacitor.

EN/PSV: Enable, PSAVE and Soft Discharge

The EN/PSV pin enables the supply. When EN/PSV is tied to VCCA the controller is enabled and power save will also be enabled. When the EN/PSV pin is tri-stated, an internal pull-up will activate the controller and power save will be disabled. If PSAVE is enabled, the SC411 PSAVE comparator will look for the inductor current to cross zero on eight consecutive switching cycles by comparing the phase node (LX) to PGND. Once observed, the controller will enter power save and turn off the low side MOSFET when the current crosses zero. To improve light-load efficiency and add hysteresis, the on-time is increased by 50% in power save. The efficiency improvement at light-loads more than offsets the disadvantage of slightly higher output ripple. If the inductor current does not cross zero on any switching cycle, the controller will immediately exit power save. Since the controller counts zero crossings, the converter can sink current as long as the current does not cross zero on eight consecutive cycles. This allows the output voltage to recover quickly in response to negative load steps even when PSAVE is enabled. If the EN/PSV pin is pulled low, the related output will be shut down and discharged using a switch with a nominal resistance of 22 Ohms. This will ensure that the output is in a defined state next time it is enabled and also ensure, since this is a soft discharge, that there are no dangerous negative voltage excursions to be concerned about. In order for the soft discharge circuitry to function correctly, the chip supply must be present.

POWER MANAGEMENT

Application Information (Cont.)

Output Voltage Selection

The output voltage is set by the feedback resistors R3 & R5 of Figure 2 below. The internal reference is 1.5V, so the voltage at the feedback pin is multiplied by three to match the 1.5V reference. Therefore the output can be set to a minimum of 0.5V. The equation for setting the output voltage is:

$$V_{OUT} = \left(1 + \frac{R3}{R5} \right) \cdot 0.5$$

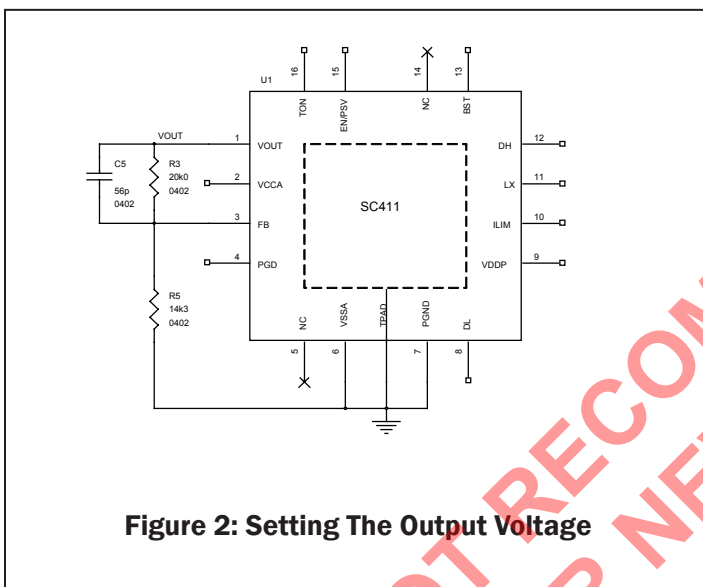

Figure 2: Setting The Output Voltage

Current Limit Circuit

Current limiting of the SC411 can be accomplished in two ways. The on-state resistance of the low-side MOSFET can be used as the current sensing element or sense resistors in series with the low-side source can be used if greater accuracy is desired. $R_{DS(ON)}$ sensing is more efficient and less expensive. In both cases, the R_{ILIM} resistor between the ILIM pin and LX pin sets the over current threshold. This resistor RILIM is connected to a 10µA current source within the SC411 which is turned on when the low side MOSFET turns on. When the voltage drop across the sense resistor or low side MOSFET equals the voltage across the RILIM resistor, positive current limit will activate. The high side MOSFET will not be turned on until the voltage drop across the sense element (resistor or MOSFET) falls below the voltage across the R_{ILIM} resis-

tor. In an extreme over-current situation, the top MOSFET will never turn back on and eventually the part will latch off due to output under-voltage (see Output Under-voltage Protection).

The current sensing circuit actually regulates the inductor valley current (see Figure 3). This means that if the current limit is set to 10A, the peak current through the inductor would be 10A plus the peak ripple current, and the average current through the inductor would be 10A plus 1/2 the peak-to-peak ripple current. The equations for setting the valley current and calculating the average current through the inductor are shown below:

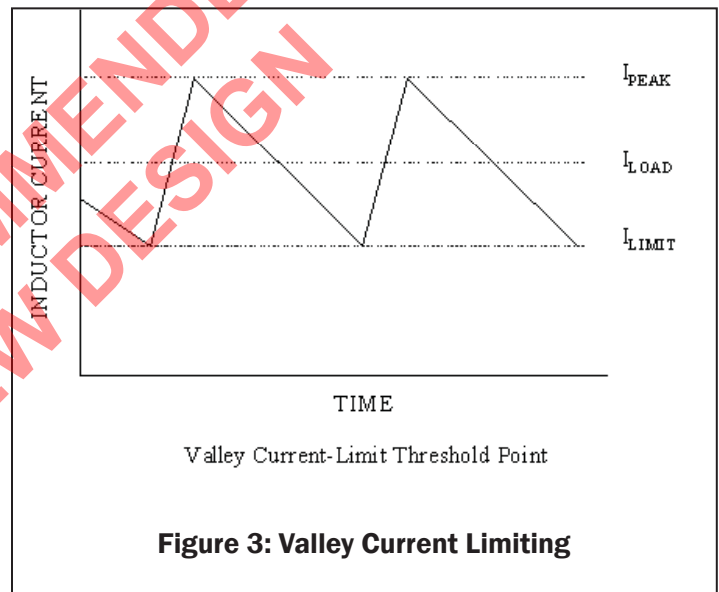

Figure 3: Valley Current Limiting

The equation for the current limit threshold is as follows:

$$I_{LIMIT} = 10\mu A \times R_{ILIM} / R_{SENSE} \text{ (Amps)}$$

Where (referring to Figure 4 on Page 17) R_{ILIM} is R4 and R_{SENSE} is the $R_{DS(ON)}$ of Q2.

For resistor sensing, a sense resistor is placed between the source of Q2 and PGND. The current through the source sense resistor develops a voltage that opposes the voltage developed across R_{ILIM} . When the voltage developed across the R_{SENSE} resistor reaches the voltage drop across R_{ILIM} , a positive over-current exists and the high side MOSFET will not be allowed to turn on. When using an external sense resistor R_{SENSE} is the resistance of the sense resistor.

POWER MANAGEMENT

Application Information (Cont.)

The current limit circuitry also protects against negative over-current (i.e. when the current is flowing from the load to PGND through the inductor and bottom MOSFET). In this case, when the bottom MOSFET is turned on, the phase node, LX, will be higher than PGND initially. The SC411 monitors the voltage at LX, and if it is greater than a set threshold voltage of 125mV (nom) the bottom MOSFET is turned off. The device then waits for approximately 2.5 μ s and then DL goes high for 300ns (typ) once more to sense the current. This repeats until either the over-current condition goes away or the part latches off due to output over-voltage (see Output Over-voltage Protection).

Power Good Output

The power good output is an open-drain output and requires a pull-up resistor. When the output voltage is 16% above or 10% below its set voltage, PGD gets pulled low. It is held low until the output voltage returns to within these tolerances once more. PGD is also held low during start-up and will not be allowed to transition high until soft start is over (440 switching cycles) and the output reaches 90% of its set voltage. There is a 5 μ s delay built into the PGD circuitry to prevent false transitions.

Output Over-Voltage Protection

When the output exceeds 16% of its set voltage the low-side MOSFET is latched on. It stays latched on and the controller is latched off until reset*. There is a 5 μ s delay built into the OV protection circuit to prevent false transitions.

Output Under-Voltage Protection

When the output is 30% below its set voltage the output is latched in a tri-stated condition. It stays latched and the controller is latched off until reset*. There is a 5 μ s delay built into the UV protection circuit to prevent false transitions.

POR, UVLO and Soft-Start

An internal power-on reset (POR) occurs when VCCA exceeds 3V, starting up the internal biasing. VCCA under-voltage lockout (UVLO) circuitry inhibits the controller until VCCA rises above 4.2V. At this time the UVLO circuitry

resets the fault latch and soft-start counter, and allows switching to occur if the device is enabled. Switching always starts with DL to charge up the BST capacitor. With the soft-start circuit (automatically) enabled, it will progressively limit the output current (by limiting the current out of the ILIM pin) over a predetermined time period of 440 switching cycles.

The ramp occurs in four steps:

- 1) 110 cycles at 25% ILIM with double minimum off-time (for purposes of the on-time one-shot, there is an internal positive offset of 120mV to VOUT during this period to aid in startup).
- 2) 110 cycles at 50% ILIM with normal minimum off-time.
- 3) 110 cycles at 75% ILIM with normal minimum off-time.
- 4) 110 cycles at 100% ILIM with normal minimum off-time.

At this point the output under-voltage and power good circuitry is enabled.

There is 100mV of hysteresis built into the UVLO circuit and when VCCA falls to 4.1V (nom) the output drivers are shut down and tri-stated.

MOSFET Gate Drivers

The DH and DL drivers are optimized for driving moderate-sized high-side, and larger low-side power MOSFETs. An adaptive dead-time circuit monitors the DL output and prevents the high-side MOSFET from turning on until DL is fully off (below \sim 1V). Semtech's SmartDriver™ FET drive first pulls DH high with a pull-up resistance of 10 Ω (typ) until LX = 1.5V (typ). At this point, an additional pull-up device is activated, reducing the resistance to 2 Ω (typ); This negates the need for an external gate or boost resistor. The adaptive dead time circuit also monitors the phase node, LX, to determine the state of the high side MOSFET, and prevents the low side MOSFET from turning on until DH is fully off (LX below \sim 1V). Be sure there is low resistance and low inductance between the DH and DL outputs to the gate of each MOSFET.

* Note: to reset from any fault, VCCA or EN/PSV must be toggled.

POWER MANAGEMENT

Application Information (Cont.)

Dropout Performance

The output voltage adjust range for continuous-conduction operation is limited by the fixed 550ns (maximum) minimum off-time one-shot. For best dropout performance, use the slowest on-time setting of 200kHz. When working with low input voltages, the duty-factor limit must be calculated using worst-case values for on and off times. The IC duty-factor limitation is given by:

$$DUTY = \frac{t_{ON(MIN)}}{t_{ON(MIN)} + t_{OFF(MAX)}}$$

Be sure to include inductor resistance and MOSFET on-state voltage drops when performing worst-case dropout duty-factor calculations.

SC411 System DC Accuracy

Two IC parameters affect system DC accuracy, the error comparator threshold voltage variation and the switching frequency variation with line and load. The error comparator threshold does not drift significantly with supply and temperature. Thus, the error comparator contributes 1.2% or less to DC system inaccuracy. Board components and layout also influence DC accuracy. The use of 1% feedback resistors contribute 1%. If tighter DC accuracy is required use 0.1% feedback resistors.

The on-pulse in the SC411 is calculated to give a pseudo-fixed frequency. Nevertheless, some frequency variation with line and load can be expected. This variation changes the output ripple voltage. Because constant-on regulators regulate to the valley of the output ripple, 1/2 of the output ripple appears as a DC regulation error. For example, if the feedback resistors are chosen to divide down the output by a factor of five, the valley of the output ripple will be VOUT. For example: if VOUT is 2.5V and the ripple is 50mV with VBAT = 6V, then the measured DC output will be 2.525V. If the ripple increases to 80mV with VBAT = 25V, then the measured DC output will be 2.540V.

The output inductor value may change with current. This will change the output ripple and thus the DC output voltage but it will not change the frequency.

Switching frequency variation with load can be minimized by choosing MOSFETs with lower RDS(ON). High RDS(ON) MOSFETs will cause the switching frequency to increase as the load current increases. This will reduce the ripple and thus the DC output voltage.

Design Procedure

Prior to designing an output and making component selections, it is necessary to determine the input voltage range and the output voltage specifications. For purposes of demonstrating the procedure the output for the schematic in Figure 4 on Page 17 will be designed.

The maximum input voltage (V_{BAT(MAX)}) is determined by the highest AC adaptor voltage. The minimum input voltage (V_{BAT(MIN)}) is determined by the lowest battery voltage after accounting for voltage drops due to connectors, fuses and battery selector switches. For the purposes of this design example we will use a V_{BAT} range of 8V to 20V.

Four parameters are needed for the output:

- 1) nominal output voltage, V_{OUT} (we will use 1.2V).
- 2) static (or DC) tolerance, TOL_{ST} (we will use +/-4%).
- 3) transient tolerance, TOL_{TR} and size of transient (we will use +/-8% and 6A for purposes of this demonstration).
- 4) maximum output current, I_{OUT} (we will design for 6A).

Switching frequency determines the trade-off between size and efficiency. Increased frequency increases the switching losses in the MOSFETs, since losses are a function of VIN². Knowing the maximum input voltage and budget for MOSFET switches usually dictates where the design ends up. A default R_{tON} value of 1MΩ is suggested as a starting point, but this is not set in stone. The first thing to do is to calculate the on-time, t_{ON}, at V_{BAT(MIN)} and V_{BAT(MAX)}, since this depends only upon V_{BAT}, V_{OUT} and R_{tON}.

For VOUT < 3.3V:

$$t_{ON_VBAT(MIN)} = \left[3.3 \cdot 10^{-12} \cdot (R_{tON} + 37 \cdot 10^3) \cdot \frac{V_{OUT}}{V_{BAT(MIN)}} \right] + 50 \cdot 10^{-9} \text{ s}$$

POWER MANAGEMENT

Application Information (Cont.)

and,

$$t_{ON_VBAT(MAX)} = \left[3.3 \cdot 10^{-12} \cdot (R_{tON} + 37 \cdot 10^3) \cdot \frac{V_{OUT}}{V_{BAT(MAX)}} \right] + 50 \cdot 10^{-9} \text{ s}$$

From these values of tON we can calculate the nominal switching frequency as follows:

$$f_{SW_VBAT(MIN)} = \left(\frac{V_{OUT}}{V_{BAT(MIN)} \cdot t_{ON_VBAT(MIN)}} \right) \text{ Hz}$$

and,

$$f_{SW_VBAT(MAX)} = \left(\frac{V_{OUT}}{V_{BAT(MAX)} \cdot t_{ON_VBAT(MAX)}} \right) \text{ Hz}$$

t_{ON} is generated by a one-shot comparator that samples V_{BAT} via R_{tON}, converting this to a current. This current is used to charge an internal 3.3pF capacitor to V_{OUT}. The equations above reflect this along with any internal components or delays that influence t_{ON}. For our example we select R_{tON} = 1MΩ:

$$t_{ON_VBAT(MIN)} = 563\text{ns} \text{ and } t_{ON_VBAT(MAX)} = 255\text{ns}$$

$$f_{SW_VBAT(MIN)} = 266\text{kHz} \text{ and } f_{SW_VBAT(MAX)} = 235\text{kHz}$$

Now that we know t_{ON} we can calculate suitable values for the inductor. To do this we select an acceptable inductor ripple current. The calculations below assume 50% of I_{OUT} which will give us a starting place.

$$L_{VBAT(MIN)} = \left(V_{BAT(MIN)} - V_{OUT} \right) \cdot \frac{t_{ON_VBAT(MIN)}}{(0.5 \cdot I_{OUT})} \text{ H}$$

and,

$$L_{VBAT(MAX)} = \left(V_{BAT(MAX)} - V_{OUT} \right) \cdot \frac{t_{ON_VBAT(MAX)}}{(0.5 \cdot I_{OUT})} \text{ H}$$

For our example:

$$L_{VBAT(MIN)} = 1.3\mu\text{H} \text{ and } L_{VBAT(MAX)} = 1.6\mu\text{H}$$

We will select an inductor value of 2.2μH to reduce the ripple current, which can be calculated as follows:

$$I_{RIPPLE_VBAT(MIN)} = \left(V_{BAT(MIN)} - V_{OUT} \right) \cdot \frac{t_{ON_VBAT(MIN)}}{L} A_{P,P}$$

and,

$$I_{RIPPLE_VBAT(MAX)} = \left(V_{BAT(MAX)} - V_{OUT} \right) \cdot \frac{t_{ON_VBAT(MAX)}}{L} A_{P,P}$$

For our example:

$$I_{RIPPLE_VBAT(MIN)} = 1.74A_{P,P} \text{ and } I_{RIPPLE_VBAT(MAX)} = 2.18A_{P,P}$$

From this we can calculate the minimum inductor current rating for normal operation:

$$I_{INDUCTOR(MIN)} = I_{OUT(MAX)} + \frac{I_{RIPPLE_VBAT(MAX)}}{2} A_{(MIN)}$$

For our example:

$$I_{INDUCTOR(MIN)} = 7.1A_{(MIN)}$$

Next we will calculate the maximum output capacitor equivalent series resistance (ESR). This is determined by calculating the remaining static and transient tolerance allowances. Then the maximum ESR is the smaller of the calculated static ESR (R_{ESR_ST(MAX)}) and transient ESR (R_{ESR_TR(MAX)}):

$$R_{ESR_ST(MAX)} = \frac{(ERR_{ST} - ERR_{DC}) \cdot 2}{I_{RIPPLE_VBAT(MAX)}} \text{ Ohms}$$

Where ERR_{ST} is the static output tolerance and ERR_{DC} is the DC error. The DC error will be 1.2% plus the tolerance of the feedback resistors, thus 2.2% total for 1% feedback resistors.

For our example:

$$ERR_{ST} = 48\text{mV} \text{ and } ERR_{DC} = 26.4\text{mV}, \text{ therefore,}$$

$$R_{ESR_ST(MAX)} = 19.8\text{m}\Omega$$

$$R_{ESR_TR(MAX)} = \frac{(ERR_{TR} - ERR_{DC})}{\left(I_{OUT} + \frac{I_{RIPPLE_VBAT(MAX)}}{2} \right)} \text{ Ohms}$$

Where ERR_{TR} is the transient output tolerance. Note that this calculation assumes that the worst case load transient is full load. For half of full load, divide the I_{OUT} term by 2.

POWER MANAGEMENT

Application Information (Cont.)

For our example:

$ERR_{TR} = 96\text{mV}$ and $ERR_{DC} = 26.4\text{mV}$, therefore,

$R_{ESR_TR(MAX)} = 9.8\text{m}\Omega$ for a full 6A load transient

We will select a value of $12.5\text{m}\Omega$ maximum for our design, which would be achieved by using two $25\text{m}\Omega$ output capacitors in parallel.

Note that for constant-on converters there is a minimum ESR requirement for stability which can be calculated as follows:

$$R_{ESR(MIN)} = \frac{3}{2 \cdot \pi \cdot C_{OUT} \cdot f_{SW}}$$

This criteria should be checked once the output capacitance has been determined.

Now that we know the output ESR we can calculate the output ripple voltage:

$$V_{RIPPLE_VBAT(MAX)} = R_{ESR} \cdot I_{RIPPLE_VBAT(MAX)} \cdot V_{P-P}$$

and,

$$V_{RIPPLE_VBAT(MIN)} = R_{ESR} \cdot I_{RIPPLE_VBAT(MIN)} \cdot V_{P-P}$$

For our example:

$$V_{RIPPLE_VBAT(MAX)} = 27\text{mV}_{P-P} \text{ and } V_{RIPPLE_VBAT(MIN)} = 22\text{mV}_{P-P}$$

Note that in order for the device to regulate in a controlled manner, the ripple content at the feedback pin, V_{FB} , should be approximately 15mV_{P-P} at minimum V_{BAT} , and worst case no smaller than 10mV_{P-P} . If $V_{RIPPLE_VBAT(MIN)}$ is less than 15mV_{P-P} the above component values should be revisited in order to improve this. Quite often a small capacitor, C_{TOP} , is required in parallel with the top feedback resistor, R_{TOP} , in order to ensure that V_{FB} is large enough. C_{TOP} should not be greater than 100pF . The value of C_{TOP} can be calculated as follows, where R_{BOT} is the bottom feedback resistor.

Firstly calculating the value of Z_{TOP} required:

$$Z_{TOP} = \frac{R_{BOT}}{0.015} \cdot (V_{RIPPLE_VBAT(MIN)} - 0.015)\text{Ohms}$$

Secondly calculating the value of C_{TOP} required to achieve this:

$$C_{TOP} = \frac{\left(\frac{1}{Z_{TOP}} - \frac{1}{R_{TOP}} \right)}{2 \cdot \pi \cdot f_{SW_VBAT(MN)}} F$$

For our example we will use $R_{TOP} = 20.0\text{k}\Omega$ and $R_{BOT} = 14.3\text{k}\Omega$, therefore,

$$Z_{TOP} = 6.67\text{k}\Omega \text{ and } C_{TOP} = 60\text{pF}$$

We will select a value of $C_{TOP} = 56\text{pF}$. Calculating the value of V_{FB} based upon the selected C_{TOP} :

$$V_{FB_VBAT(MIN)} = V_{RIPPLE_VBAT(MIN)} \cdot \left(\frac{R_{BOT}}{R_{BOT} + \frac{1}{\frac{1}{R_{TOP}} + 2 \cdot \pi \cdot f_{SW_VBAT(MN)} \cdot C_{TOP}}} \right) V_{P-P}$$

For our example:

$$V_{FB_VBAT(MIN)} = 14.8\text{mV}_{P-P} - \text{good}$$

Next we need to calculate the minimum output capacitance required to ensure that the output voltage does not exceed the transient maximum limit, $POSLIM_{TR}$, starting from the actual static maximum, $V_{OUT_ST_POS}$, when a load release occurs:

$$V_{OUT_ST_POS} = V_{OUT} + ERR_{DC} V$$

For our example:

$$V_{OUT_ST_POS} = 1.226V$$

$$POSLIM_{TR} = V_{OUT} \cdot TOL_{TR} V$$

POWER MANAGEMENT

Application Information (Cont.)

Where TOL_{TR} is the transient tolerance. For our example:

$$POSLIM_{TR} = 1.296V$$

The minimum output capacitance is calculated as follows:

$$C_{COUT(MIN)} = L \cdot \frac{\left(I_{OUT} + \frac{I_{RIPPLE_VBAT(MAX)}}{2} \right)^2}{\left(POSLIM_{TR}^2 - V_{OUT_ST_POS}^2 \right)} F$$

This calculation assumes the absolute worst case condition of a full-load to no load step transient occurring when the inductor current is at its highest. The capacitance required for smaller transient steps may be calculated by substituting the desired current for the I_{OUT} term.

For our example:

$$C_{OUT(MIN)} = 626\mu F.$$

We will select 440 μ F, using two 220 μ F, 25m Ω capacitors in parallel. For smaller load release overshoot, 660 μ F may be used. Alternatively, one 15m Ω or 12m Ω , 220 μ F, 330 μ F or 470 μ F capacitor may be used (with the appropriate change to the calculation for C_{TOP}), depending upon the load transient requirements.

Next we calculate the RMS input ripple current, which is largest at the minimum battery voltage:

$$I_{IN(RMS)} = \sqrt{V_{OUT} \cdot (V_{BAT(MIN)} - V_{OUT})} \cdot \frac{I_{OUT}}{V_{BAT_MIN}} A_{RMS}$$

For our example:

$$I_{IN(RMS)} = 2.14A_{RMS}$$

Input capacitors should be selected with sufficient ripple current rating for this RMS current, for example a 10 μ F, 1210 size, 25V ceramic capacitor can handle approximately 3 A_{RMS} . Refer to manufacturer's data sheets and derate appropriately.

Finally, we calculate the current limit resistor value. As described in the current limit section, the current limit looks at the "valley current", which is the average output current minus half the ripple current. We use the maximum room temperature specification for MOSFET $R_{DS(ON)}$ at $V_{GS} = 4.5V$ for purposes of this calculation:

$$I_{VALLEY} = I_{OUT} - \frac{I_{RIPPLE_VBAT(MIN)}}{2} A$$

The ripple at low battery voltage is used because we want to make sure that current limit does not occur under normal operating conditions.

$$R_{ILIM} = (I_{VALLEY} \cdot 1.2) \cdot \frac{R_{DS(ON)} \cdot 1.4}{10 \cdot 10^{-6}} \text{ Ohms}$$

For our example:

$$I_{VALLEY} = 5.13A, R_{DS(ON)} = 9m\Omega \text{ and } R_{ILIM} = 7.76k\Omega$$

We select the next lowest 1% resistor value: 7.68k Ω

Thermal Considerations

The junction temperature of the device may be calculated as follows:

$$T_J = T_A + P_D \cdot \theta_{JA} \text{ } ^\circ C$$

Where:

- T_A = ambient temperature ($^\circ C$)
- P_D = power dissipation in (W)
- θ_{JA} = thermal impedance junction to ambient from absolute maximum ratings ($^\circ C/W$)

The power dissipation may be calculated as follows:

$$P_D = V_{CCA} \cdot I_{VCCA} + V_{DDP} \cdot I_{VDDP} + V_g \cdot Q_g \cdot f + V_{BST} \cdot I_{mA} \cdot D \text{ W}$$

Where:

- V_{CCA} = chip supply voltage (V)
- I_{VCCA} = operating current (A)
- V_{DDP} = gate drive supply voltage (V)

POWER MANAGEMENT

Application Information (Cont.)

- I_{VDDP} = gate drive operating current (A)
- V_g = gate drive voltage, typically 5V (V)
- Q_g = FET gate charge, from the FET datasheet (C)
- f = switching frequency (kHz)
- $VBST$ = boost pin voltage during t_{ON} (V)
- D = duty cycle

Inserting the following values for $VBAT_{(MIN)}$ condition (since this is the worst case condition for power dissipation in the controller) as an example ($VOUT = 1.2V$),

- T_A = 85 °C
- θ_{JA} = 100 °C/W
- $VCCA$ = $VDDP = 5V$
- I_{VCCA} = 1100µA (data sheet maximum)
- I_{VDDP} = 150µA (data sheet maximum)
- V_g = 5V
- Q_g = 60nC
- f = 266kHz
- $VBAT_{(MIN)}$ = 8V
- $VBST_{(MIN)} = VBAT_{(MIN)} + VDDP = 13V$
- $D_{(MIN)} = 1.2/8 = 0.15$

gives us,

$$P_D = 5 \cdot 1100 \cdot 10^{-6} + 5 \cdot 150 \cdot 10^{-6} + 5 \cdot 60 \cdot 10^{-9} \cdot 266 \cdot 10^3 + 13 \cdot 1 \cdot 10^{-3} \cdot 0.15 = 0.088 \text{ W}$$

and,

$$T_j = 85 + 0.088 \cdot 100 = 93.8 \text{ °C}$$

As can be seen, the heating effects due to internal power dissipation are practically negligible, thus requiring no special thermal consideration during layout.

The Reference Design is shown in Figure on Page 17.

An additional design optimized for efficiency and capable of a higher load current of 10A is shown in Figure 11 on Page 21.



POWER MANAGEMENT

Layout Guidelines

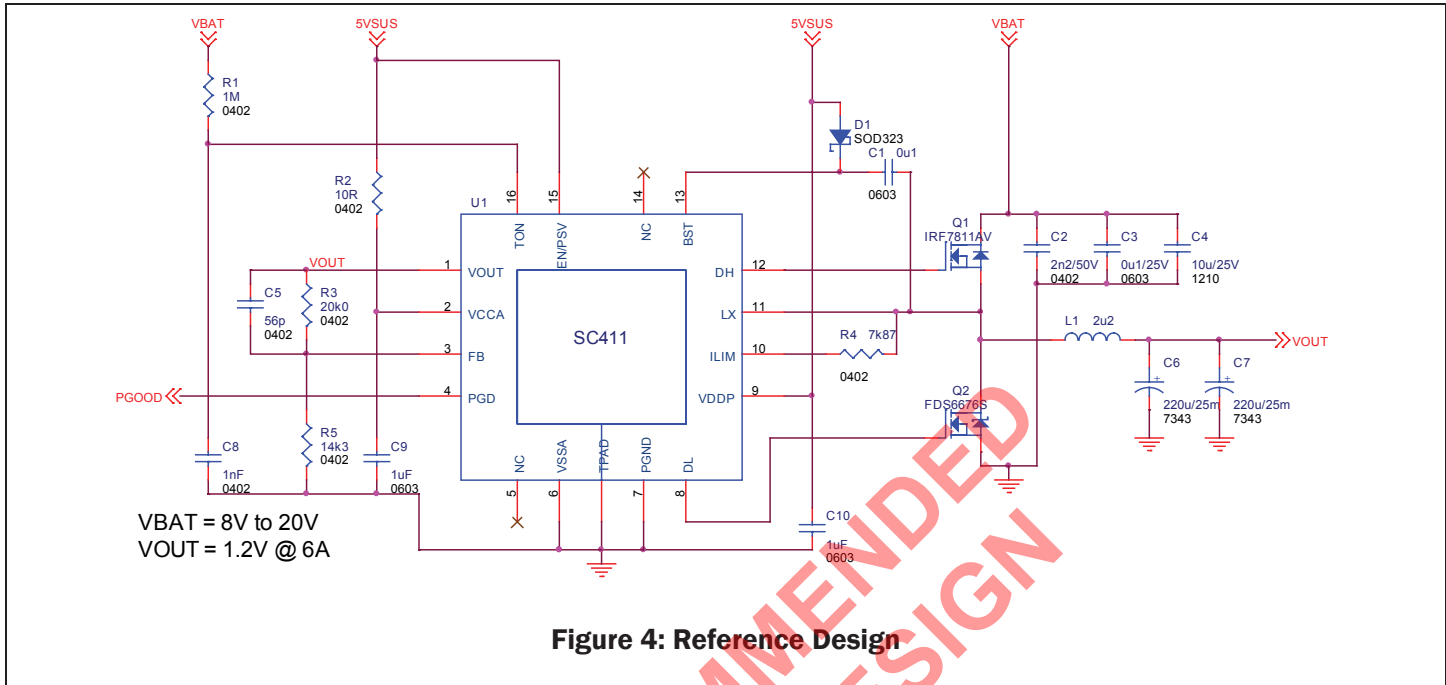

One (or more) ground planes is/are recommended to minimize the effect of switching noise and copper losses, and maximize heat dissipation. The IC ground reference, VSSA, and the power ground pin, PGND, should both connect directly to the device thermal pad. The thermal pad should connect to the ground plane(s) using multiple vias.

The VOUT feedback trace must be kept far away from noise sources such as switching nodes, inductors and gate drives. Route the feedback trace in a quiet layer (if possible) from the output capacitor back to the chip. All components should be located adjacent to their respective pins with an emphasis on the chip decoupling capacitors (VCCA and VDDP) and the components that are shown connecting to VSSA in the above schematic. Make any ground connections simply to the ground plane.

Power sections should connect directly to the ground plane(s) using multiple vias as required for current handling (including the chip power ground connections). Power components should be placed to minimize loops and reduce losses. Make all the connections on one side of the PCB using wide copper filled areas if possible. Do not use “minimum” land patterns for power components. Minimize trace lengths between the gate drivers and the gates of the MOSFETs to reduce parasitic impedances (and MOSFET switching losses), the low-side MOSFET is most critical. Maintain a length to width ratio of <20:1 for gate drive signals. Use multiple vias as required by current handling requirements (and to reduce parasitics) if routed on more than one layer. Current sense connections must always be made using Kelvin connections to ensure an accurate signal, with the current limit resistor located at the device.

We will examine the reference design used in the Design Procedure section while explaining the layout guidelines in more detail.

POWER MANAGEMENT

The layout can be considered in two parts, the control section referenced to VSSA and the power section. Looking at the control section first, locate all components referenced to VSSA on the schematic and place these components at the chip. Drop vias to the ground plane as needed.

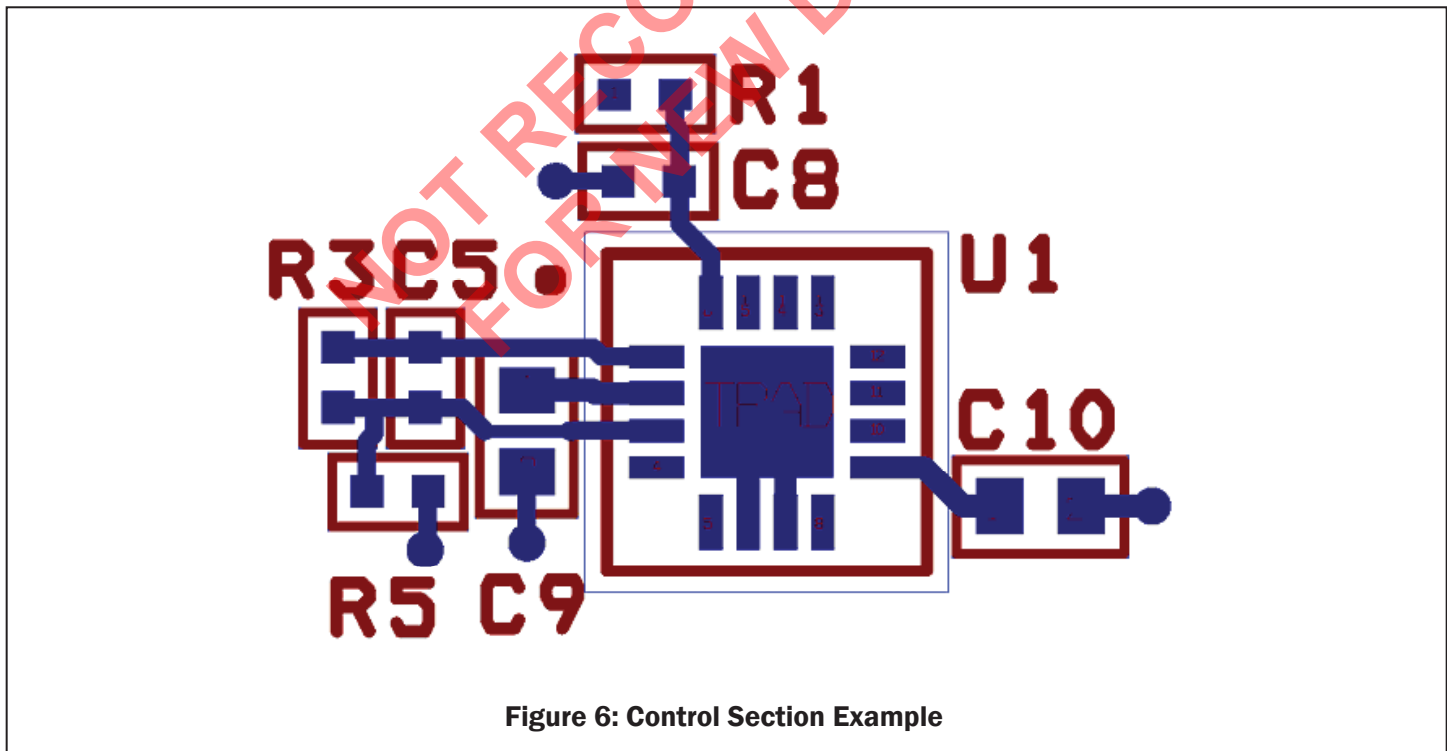
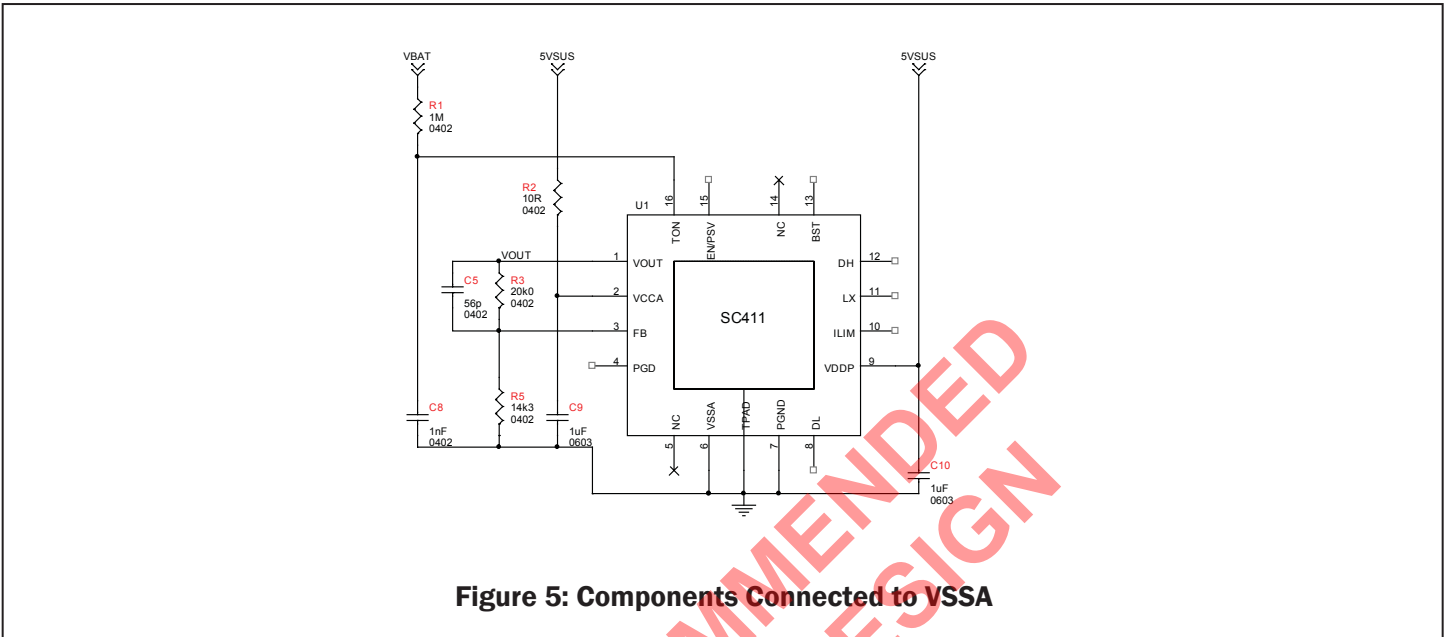

In Figure 6 above, all components referenced to VSSA have been placed and connected to the ground plane with vias. Decoupling capacitors C9 and C10 are as close as possible to their pins and connected to the ground plane with vias. Note how the VSSA and PGND pins are connected directly to the thermal pad, which has 4 vias to the ground plane (not shown).

POWER MANAGEMENT

As shown below, VOUT should be routed away from noisy traces (such as BST, DH, DL and LX) and in a quiet layer (if possible) to the output capacitor(s).

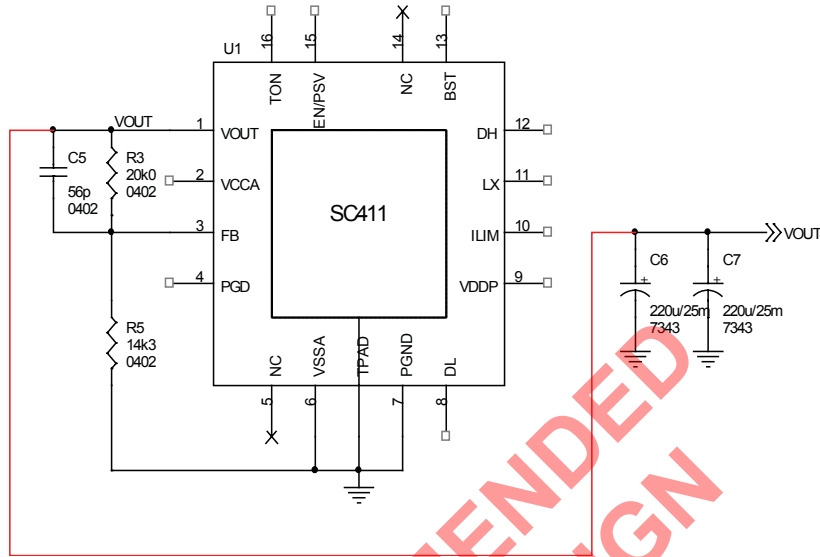

Figure 7: VOUT Sense Trace Routing

Next, the schematic in Figure 8 below shows the power section. The highest di/dts occur in the input loop (highlighted in red) and thus this loop should be kept as small as possible.

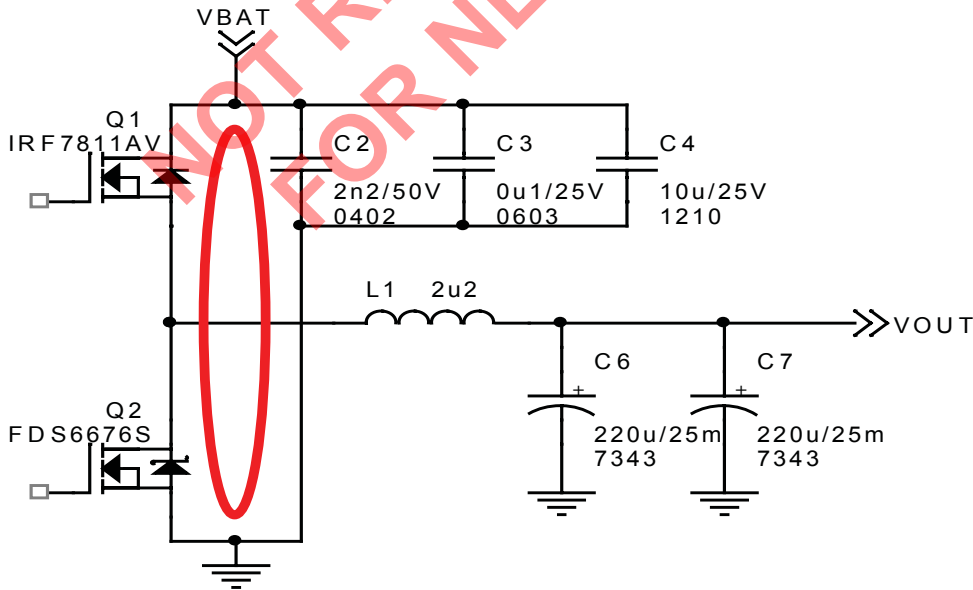

Figure 8: Power Section and Input Loop

The input capacitors should be placed with the highest frequency capacitors closest to the loop to reduce EMI. Use large copper pours to minimize losses and parasitics. See Figure 9 for an example.

POWER MANAGEMENT

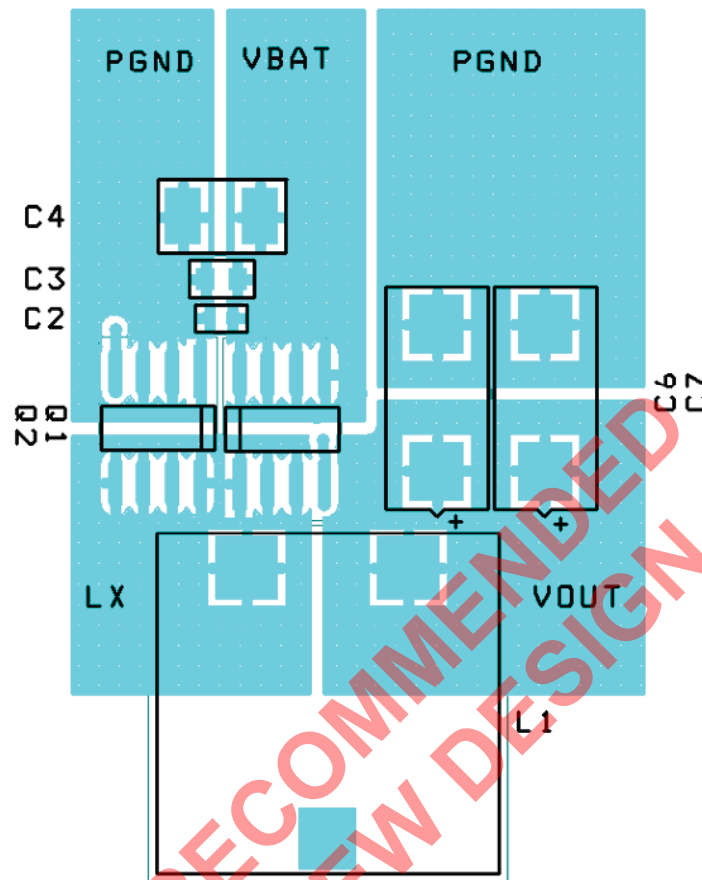

Figure 9: Power Component Placement and Copper Pours

Key points for the power section:

- 1) There should be a very small input loop, well decoupled.
- 2) The phase node should be a large copper pour, but compact since this is the noisiest node.
- 3) Input power ground and output power ground should not connect directly, but through the ground planes instead.
- 4) The current limit resistor should be placed as close as possible to the ILIM and LX pins.

Connecting the control and power sections should be accomplished as follows (see Figure 10 on the following page):

- 1) Route VOUT in a “quiet” layer away from noise sources.
- 2) Route DL, DH and LX (low side FET gate drive, high side FET gate drive and phase node) to chip using wide traces with multiple vias if using more than one layer. These connections to be as short as possible for loop minimization, with a length to width ratio less than 20:1 to minimize impedance. DL is the most critical gate drive, with power ground as its return path. LX is the noisiest node in the circuit, switching between VBAT and ground at high frequencies, thus should be kept as short as practical. DH has LX as its return path.
- 3) BST is also a noisy node and should be kept as short as possible.
- 4) Connect PGND and VSSA directly to the thermal pad, and connect the thermal pad to the ground plane using multiple vias.

POWER MANAGEMENT

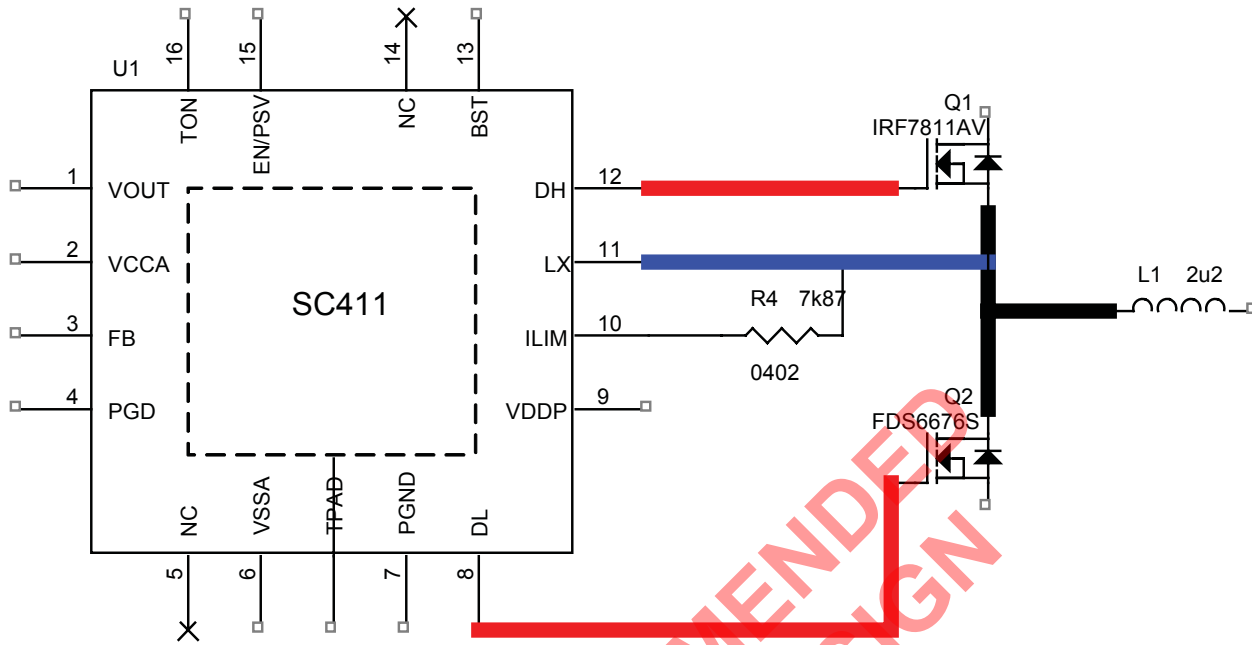

Figure 10: Connecting the Control and Power Sections

Phase nodes (black) to be copper islands (preferred) or wide copper traces. Gate drive traces (red) and phase node traces (blue) to be wide copper traces (L:W < 20:1) and as short as possible, with DL the most critical.

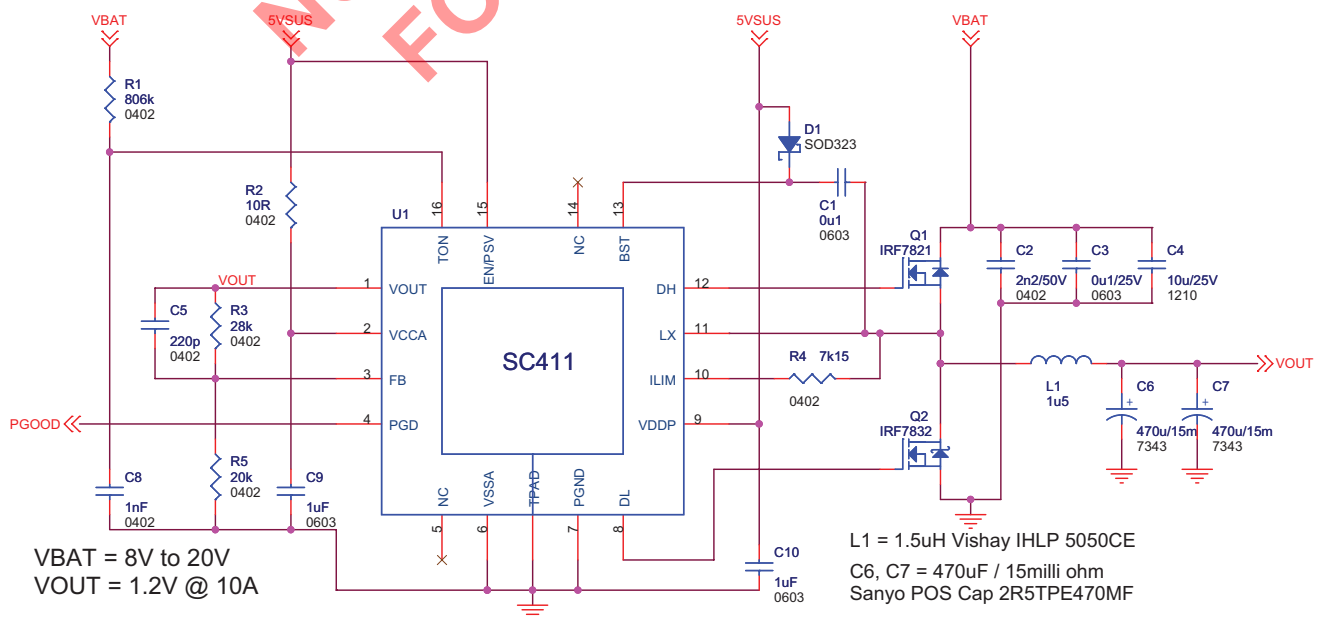

Figure 11: High Efficiency Design

POWER MANAGEMENT

Typical Characteristics

For efficiency charts, refer to High Efficiency Design, Figure 11 on page 21.

For all other data, refer to the Reference Design, Figure 4 on page 17.

**1.2V Efficiency (Power Save Mode)
(High Efficiency Design, Page 21)**

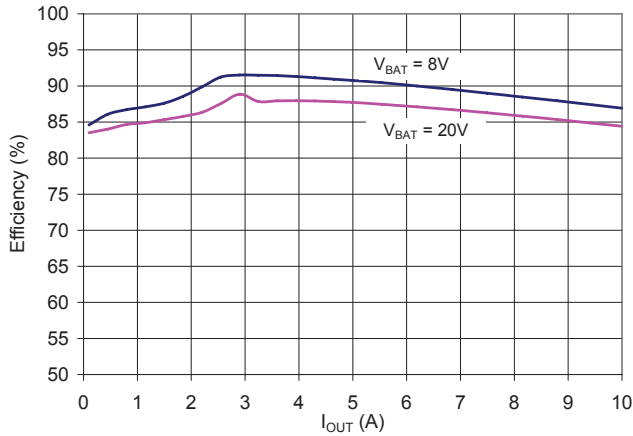

**1.2V Efficiency (Continuous Conduction Mode)
(High Efficiency Design, Page 21)**

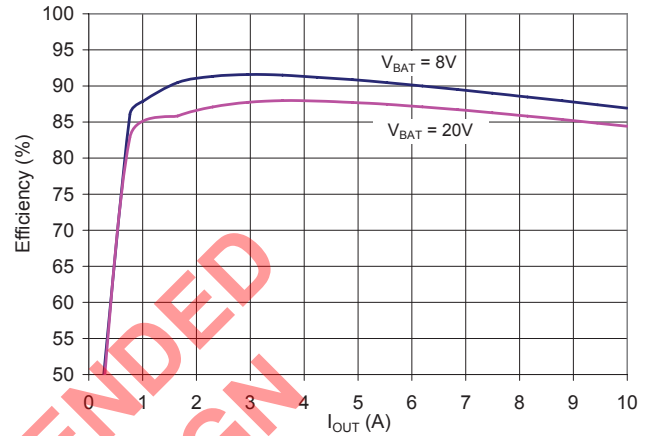

**1.2V Output Voltage (Power Save Mode)
vs. Output Current vs. Input Voltage**

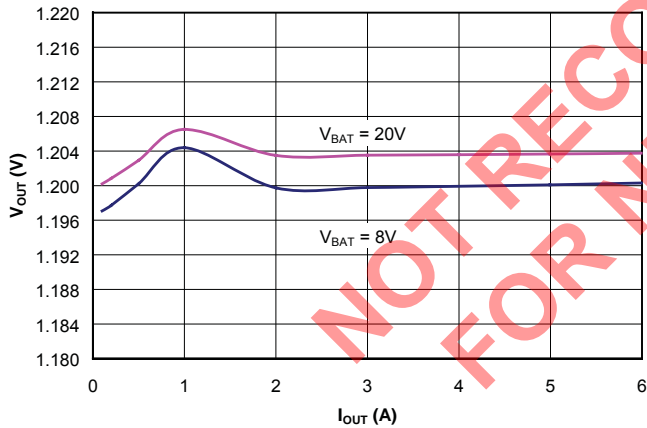

**1.2V Output Voltage (Continuous Conduction Mode)
vs. Output Current vs. Input Voltage**

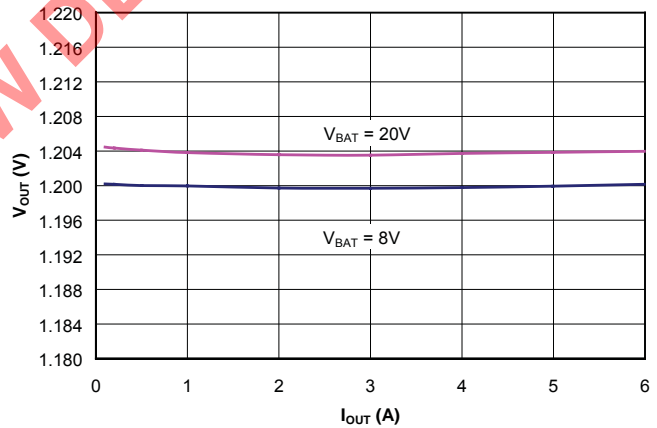

**1.2V Switching Frequency (Power Save Mode)
vs. Output Current vs. Input Voltage**

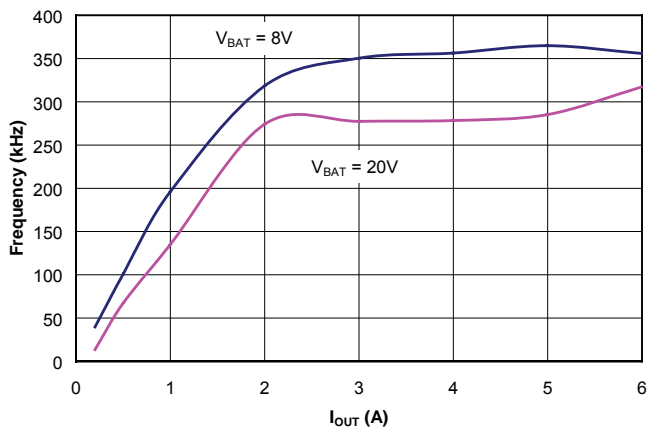

**1.2V Switching Frequency (Continuous Conduction Mode)
vs. Output Current vs. Input Voltage**

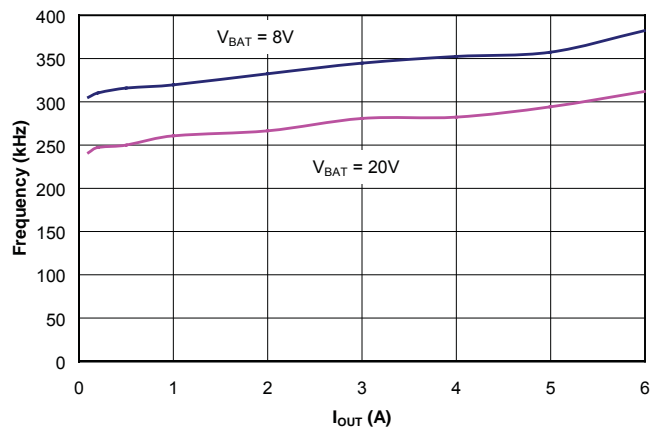

POWER MANAGEMENT

Typical Characteristics

**Load Transient Response,
Continuous Conduction Mode, 0A to 6A to 0A**

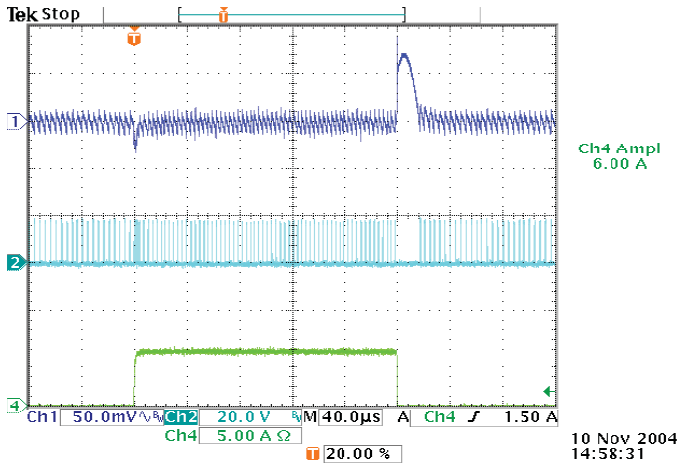

Trace 1: 1.2V, 50mV/div., AC coupled
Trace 2: LX, 20V/div
Trace 3: not connected
Trace 4: load current, 5A/div
Timebase: 40µs/div.

**Load Transient Response,
Continuous Conduction Mode, 0A to 6A Zoomed**

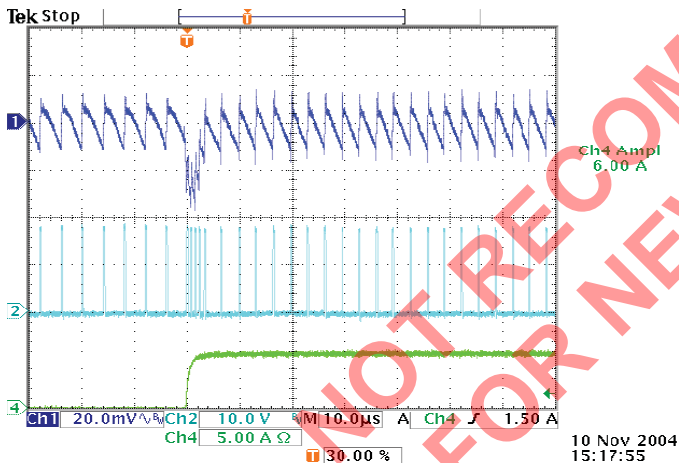

Trace 1: 1.2V, 20mV/div., AC coupled
Trace 2: LX, 10V/div
Trace 3: not connected
Trace 4: load current, 5A/div
Timebase: 10µs/div.

**Load Transient Response,
Continuous Conduction Mode, 6A to 0A Zoomed**

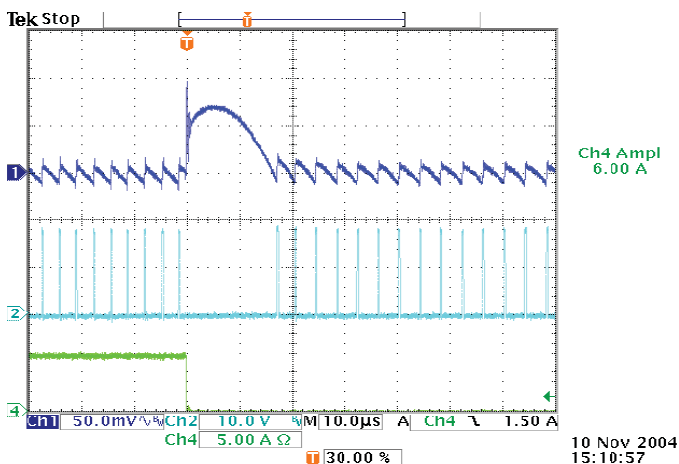

Trace 1: 1.2V, 50mV/div., AC coupled
Trace 2: LX, 10V/div
Trace 3: not connected
Trace 4: load current, 5A/div
Timebase: 10µs/div.

Please refer to Figure 4 on Page 17 for test schematic

POWER MANAGEMENT

Typical Characteristics

**Load Transient Response,
Power Save Mode, 0A to 6A to 0A**

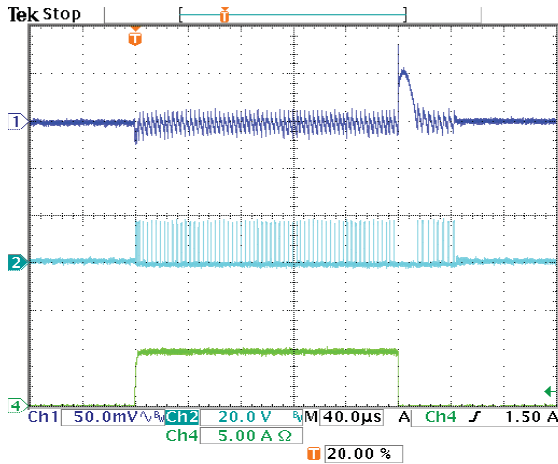

Trace 1: 1.2V, 50mV/div., AC coupled
Trace 2: LX, 20V/div
Trace 3: not connected
Trace 4: load current, 5A/div
Timebase: 40µs/div.

10 Nov 2004
14:58:00

Startup (CCM), EN/PSV 0V to Floating

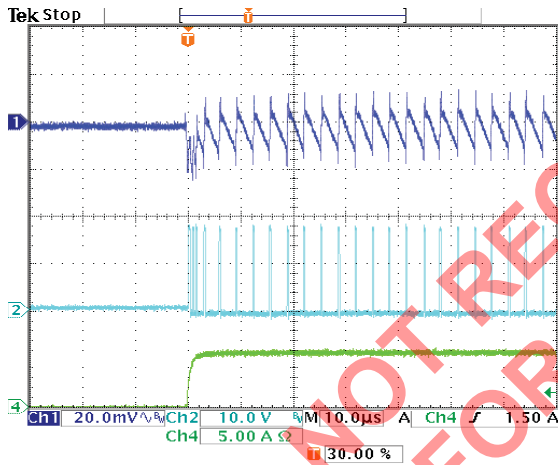

Trace 1: 1.2V, 20mV/div., AC coupled
Trace 2: LX, 10V/div
Trace 3: not connected
Trace 4: load current, 5A/div
Timebase: 10µs/div.

10 Nov 2004
15:05:01

**Load Transient Response,
Power Save Mode, 6A to 0A Zoomed**

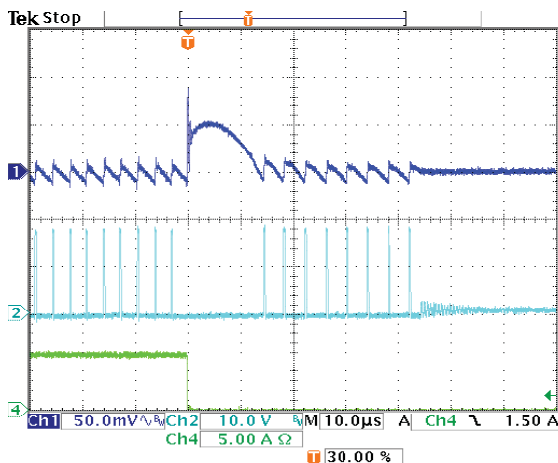

Trace 1: 1.2V, 50mV/div., AC coupled
Trace 2: LX, 10V/div
Trace 3: not connected
Trace 4: load current, 5A/div
Timebase: 10µs/div.

10 Nov 2004
15:15:18

Please refer to Figure 4 on Page 17 for test schematic

POWER MANAGEMENT

Typical Characteristics

Startup (PSV), EN/PSV Going High

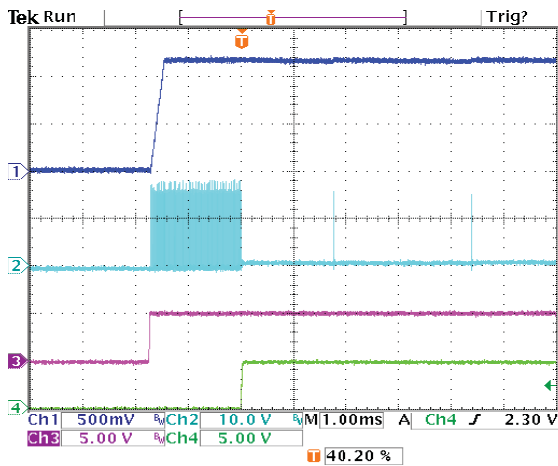

Trace 1: 1.2V, 0.5V/div.
 Trace 2: LX, 10V/div
 Trace 3: EN/PSV, 5V/div
 Trace 4: PGD, 5V/div.
 Timebase: 1ms/div.

Startup (CCM), EN/PSV 0V to Floating

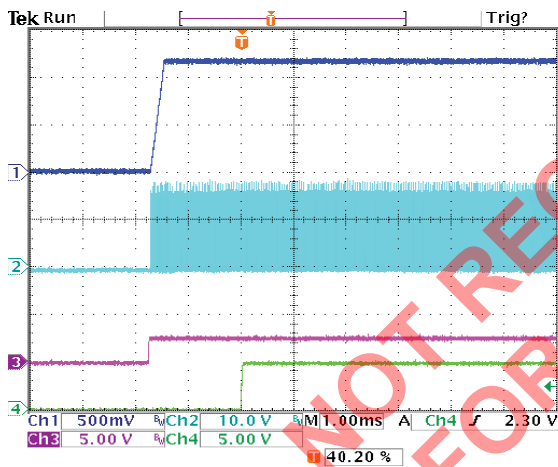

Trace 1: 1.2V, 0.5V/div.
 Trace 2: LX, 10V/div
 Trace 3: EN/PSV, 5V/div
 Trace 4: PGD, 5V/div.
 Timebase: 1ms/div.

Please refer to Figure 4 on Page 17 for test schematic

POWER MANAGEMENT

Outline Drawing - MLPQ-16

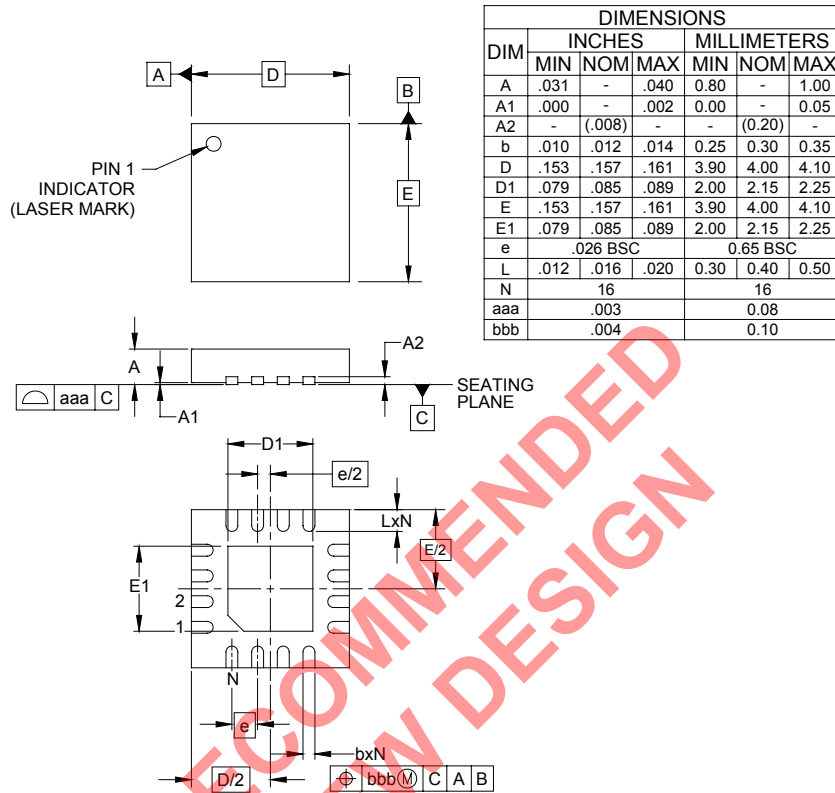

- NOTES:
1. CONTROLLING DIMENSIONS ARE IN MILLIMETERS (ANGLES IN DEGREES).
 2. COPLANARITY APPLIES TO THE EXPOSED PAD AS WELL AS THE TERMINALS.

Marking Information

Top Marking



yyww = Date Code (Example: 0552)
 xxxxx = Semtech Lot Number (Example: E9010)
 xxxxx = (Example: 1-100)

POWER MANAGEMENT

Land Pattern - MLPQ-16

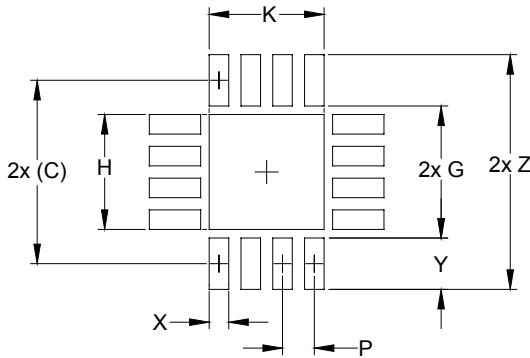

DIMENSIONS		
DIM	INCHES	MILLIMETERS
C	(.152)	(3.85)
G	.114	2.90
H	.091	2.30
K	.091	2.30
P	.026	0.65
X	.016	0.40
Y	.037	0.95
Z	.189	4.80

NOTES:

1. THIS LAND PATTERN IS FOR REFERENCE PURPOSES ONLY. CONSULT YOUR MANUFACTURING GROUP TO ENSURE YOUR COMPANY'S MANUFACTURING GUIDELINES ARE MET.

NOT RECOMMENDED FOR NEW DESIGN

Contact Information

Taiwan Branch

Tel: 886-2-2748-3380
Fax: 886-2-2748-3390

Semtech Switzerland GmbH
Japan Branch

Tel: 81-3-6408-0950
Fax: 81-3-6408-0951

Korea Branch

Tel: 82-2-527-4377
Fax: 82-2-527-4376

Semtech Limited (U.K.)

Tel: 44-1794-527-600
Fax: 44-1794-527-601

Shanghai Office

Tel: 86-21-6391-0830
Fax: 86-21-6391-0831

Semtech France SARL

Tel: 33-(0)169-28-22-00
Fax: 33-(0)169-28-12-98

Semtech International AG is a wholly-owned subsidiary of Semtech Corporation, which has its headquarters in the U.S.A.

Semtech Germany GmbH

Tel: 49-(0)8161-140-123
Fax: 49-(0)8161-140-124