

### PROTECTION PRODUCTS - RailClamp®

#### Description

The RailClamp family is a series of ultra low capacitance Transient Voltage Suppressors (TVS) designed to protect high speed data interfaces. This series has been specifically designed to protect sensitive components which are connected to high-speed data and transmission lines from overvoltage caused by **ESD** (electrostatic discharge), **CDE** (Cable Discharge Events), and **EFT** (electrical fast transients).

The RClamp™0821P has a maximum capacitance of only 0.50pF. This allows it to be used on circuits operating in excess of 3GHz without signal attenuation. They may be used to meet the ESD immunity requirements of IEC 61000-4-2, Level 4 ( $\pm 15\text{kV}$  air,  $\pm 8\text{kV}$  contact discharge).

The RClamp0821P is in a 2-pin, RoHS/WEEE compliant, SLP1006P2 package measuring 1.0 x 0.6 x 0.5mm. The leads are spaced at a pitch of 0.65mm and feature a lead-free finish. Each device will protect one high-speed line operating at 8 volts. It gives the designer the flexibility to protect single lines in applications where arrays are not practical. The combination of small size, low capacitance, and high ESD surge capability makes them ideal for use in applications such as cellular phones and digital video interfaces.

#### Features

- ◆ Transient protection for data lines to **IEC 61000-4-2 (ESD)  $\pm 15\text{kV}$  (air),  $\pm 8\text{kV}$  (contact)**  
**IEC 61000-4-4 (EFT) 40A (tp = 5/50ns)**  
**Cable Discharge Event (CDE)**
- ◆ Ultra-small package (1.0 x 0.6 x 0.5mm)
- ◆ Protects one data or I/O line
- ◆ Low capacitance: **0.3pF** typical
- ◆ Low clamping voltage
- ◆ Low operating voltage: 8.0V
- ◆ Solid-state silicon-avalanche technology

#### Mechanical Characteristics

- ◆ SLP1006P2 package
- ◆ Molding compound flammability rating: UL 94V-0
- ◆ Marking: Marking code
- ◆ Packaging : Tape and Reel
- ◆ Lead Finish: NiPdAu
- ◆ RoHS/WEEE Compliant

#### Applications

- ◆ Cellular Handsets & Accessories
- ◆ Digital Visual Interface (DVI)
- ◆ Display Port
- ◆ MDDI Ports
- ◆ USB Ports
- ◆ PCI Express
- ◆ Serial ATA

#### Dimensions

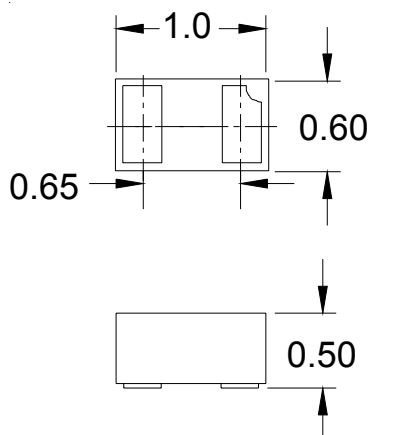

#### Schematic & PIN Configuration

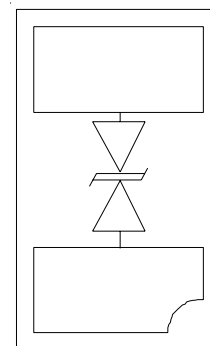

SLP1006P2 (Bottom View)

## PROTECTION PRODUCTS

### Absolute Maximum Rating

Rating	Symbol	Value	Units
Peak Pulse Power (tp = 8/20μs)	$P_{pk}$	100	Watts
Peak Pulse Current (tp = 8/20μs)	$I_{pp}$	4	A
ESD per IEC 61000-4-2 (Air) ESD per IEC 61000-4-2 (Contact)	$V_{ESD}$	+/- 15 +/- 8	kV
Operating Temperature	$T_J$	-55 to +125	°C
Storage Temperature	$T_{STG}$	-55 to +150	°C

### Electrical Characteristics (T=25°C)

Parameter	Symbol	Conditions	Minimum	Typical	Maximum	Units
Reverse Stand-Off Voltage	$V_{RWM}$				8	V
Reverse Breakdown Voltage	$V_{BR}$	$I_t = 1mA$	10			V
Reverse Leakage Current	$I_R$	$V_{RWM} = 8V, T=25^\circ C$			1	μA
Clamping Voltage	$V_C$	$I_{pp} = 1A, tp = 8/20\mu s$			20	V
Clamping Voltage	$V_C$	$I_{pp} = 4A, tp = 8/20\mu s$			25	V
Junction Capacitance	$C_J$	$V_R = 0V, f = 1MHz$		0.30	0.50	pF

**PROTECTION PRODUCTS**

Typical Characteristics

**Non-Repetitive Peak Pulse Power vs. Pulse Time**

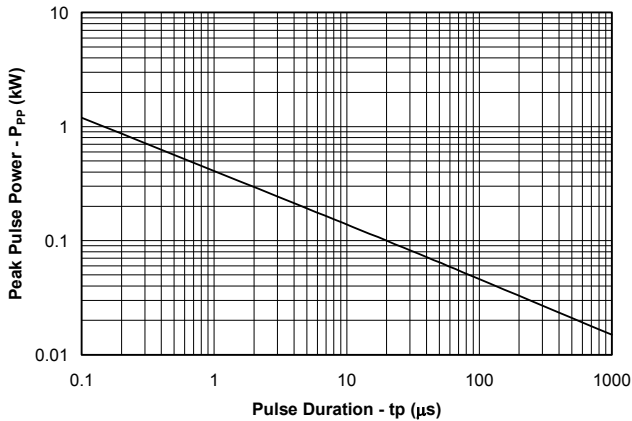

**Power Derating Curve**

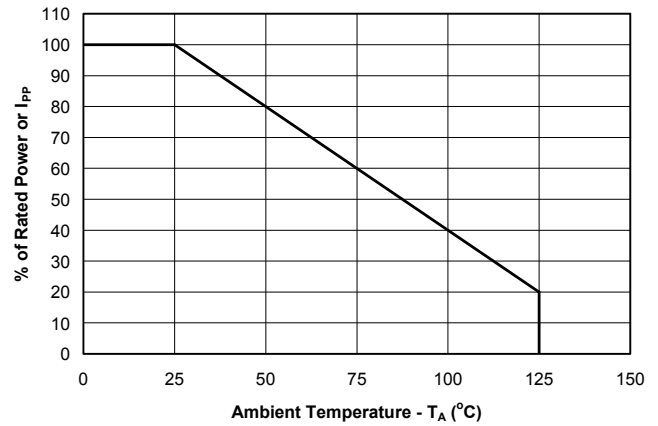

**Clamping Voltage vs. Peak Pulse Current**

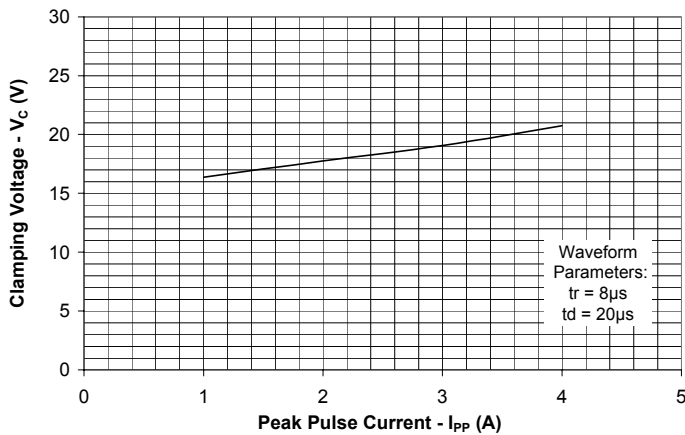

**Normalized Capacitance vs. Reverse Voltage**

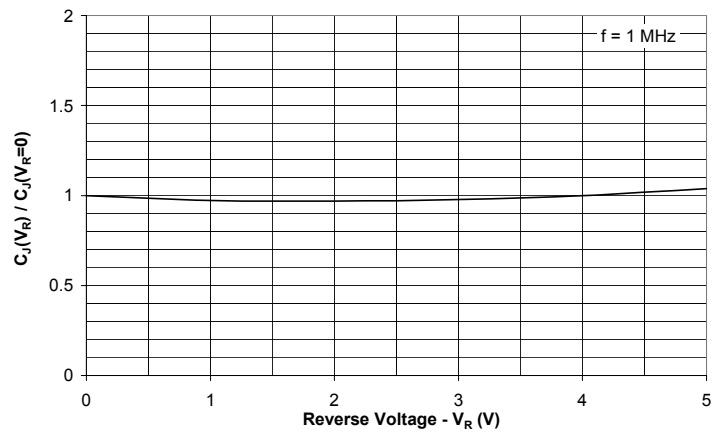

**ESD Clamping  
(8kV Contact per IEC 61000-4-2)**

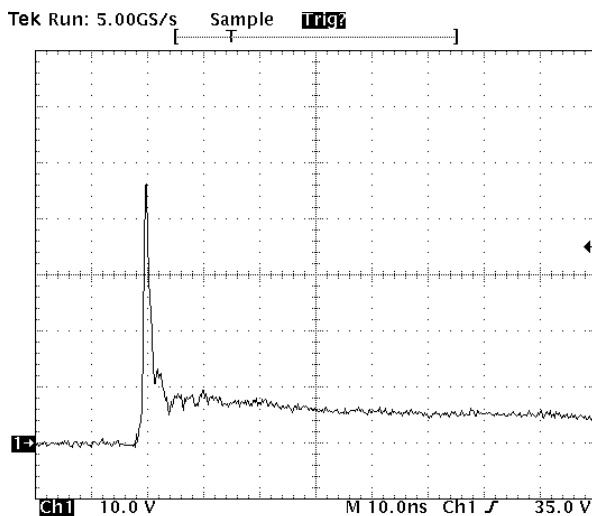

**Insertion Loss S21**

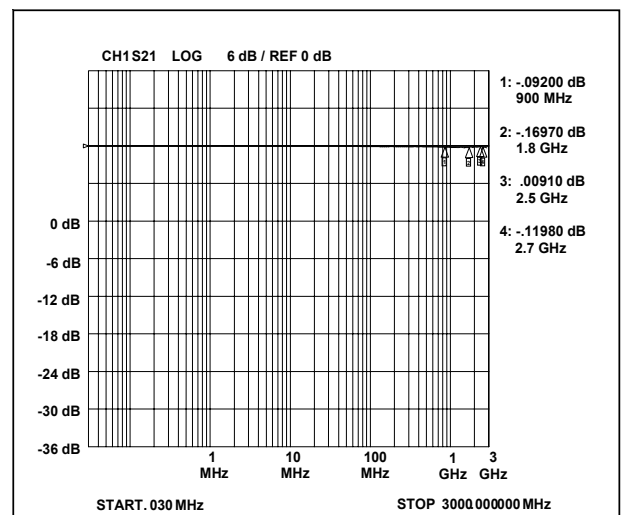

**PROTECTION PRODUCTS****Applications Information****Device Connection Options**

These low capacitance TVS diodes are designed to provide common mode protection for one high-speed line or differential protection for one line pair. The device is bidirectional and may be used on lines where the signal polarity is positive and negative.

**Circuit Board Layout Recommendations for Suppression of ESD.**

Good circuit board layout is critical for the suppression of ESD induced transients. The following guidelines are recommended:

- Place the TVS near the input terminals or connectors to restrict transient coupling.
- Minimize the path length between the TVS and the protected line.
- Minimize all conductive loops including power and ground loops.
- The ESD transient return path to ground should be kept as short as possible.
- Never run critical signals near board edges.
- Use ground planes whenever possible.

**Equivalent Circuit Diagram**

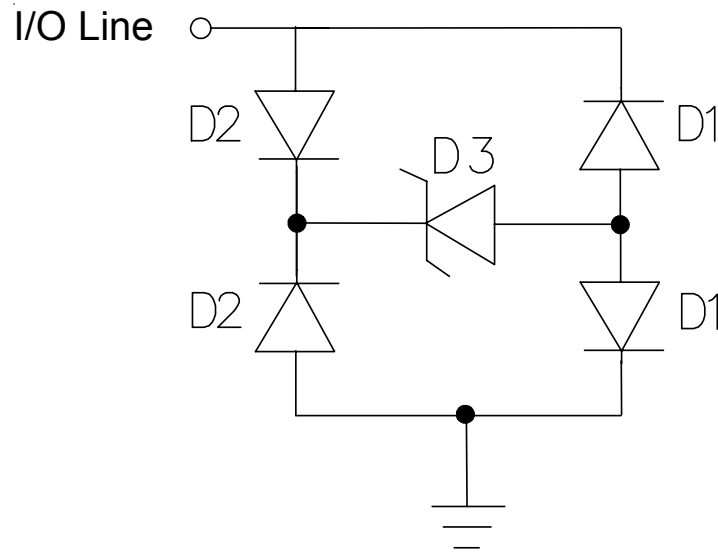

**RClamp0821P Spice Model**

**Table 1 - RClamp0821P Spice Parameters**

Parameter	Unit	D1 (LCRD)	D2 (LCRD)	D3 (TVS)
IS	Amp	1.0E-20	1.0E-20	2.0E-12
BV	Volt	100	100	13.7
VJ	Volt	0.7	0.7	0.6
RS	Ohm	0.458	0.89	0.8
IBV	Amp	1E-3	1E-3	1E-3
CJO	Farad	0.4E-12	0.4E-12	56E-12
TT	sec	2.541E-9	2.541E-9	2.541E-9
M	--	0.01	0.01	0.23
N	--	1.1	1.1	1.1
EG	eV	1.11	1.11	1.11

**PROTECTION PRODUCTS**

**Outline Drawing - SLP1006P2**

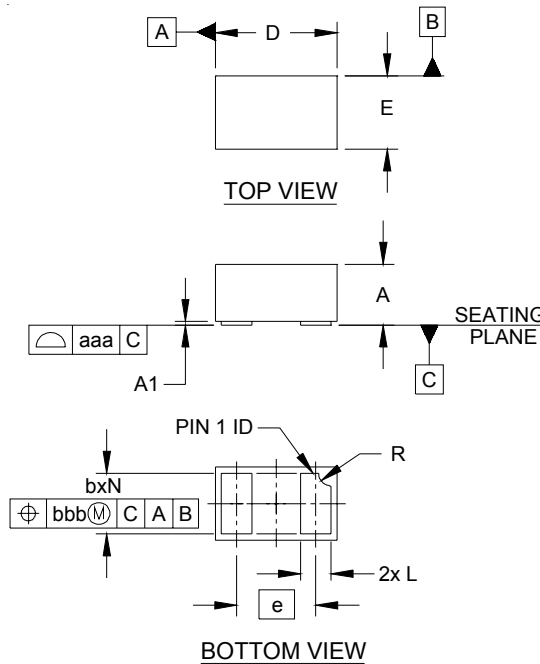

DIM	INCHES		MILLIMETERS		
	MIN	NOM/MAX	MIN	NOM	MAX
A	.016	.020 .022	0.40	0.50	0.55
A1	.000	.001 .002	0.00	0.03	0.05
b	.018	.020 .022	0.45	0.50	0.55
D	.035	.039 .043	0.90	1.00	1.10
E	.020	.024 .028	0.50	0.60	0.70
e	.026 BSC		0.65 BSC		
L	.008	.010 .012	0.20	0.25	0.30
R	.002	.004 .006	0.05	0.10	0.15
N	2		2		
aaa	.003		0.08		
bbb	.004		0.10		

**NOTES:**

1. CONTROLLING DIMENSIONS ARE IN MILLIMETERS (ANGLES IN DEGREES).

**Land Pattern - SLP1006P2**

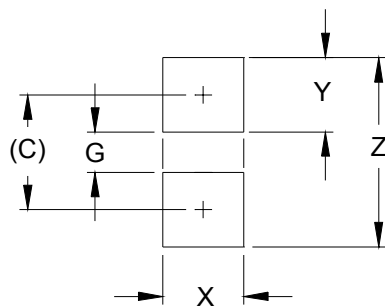

DIM	DIMENSIONS	
	INCHES	MILLIMETERS
C	(.033)	(0.85)
G	.012	0.30
X	.024	0.60
Y	.022	0.55
Z	.055	1.40

**NOTES:**

1. CONTROLLING DIMENSIONS ARE IN MILLIMETERS (ANGLES IN DEGREES).
2. THIS LAND PATTERN IS FOR REFERENCE PURPOSES ONLY.  
CONSULT YOUR MANUFACTURING GROUP TO ENSURE YOUR COMPANY'S MANUFACTURING GUIDELINES ARE MET.

## PROTECTION PRODUCTS

### Marking Code

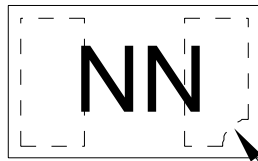

PIN 1 ID

### Ordering Information

Part Number	Qty per Reel	Reel Size
RClamp0821P.TCT	3,000	7 Inch

Note: Lead finish is lead-free NiPdAu.

RailClamp and RClamp are marks of Semtech Corporation.

### Tape and Reel Specification

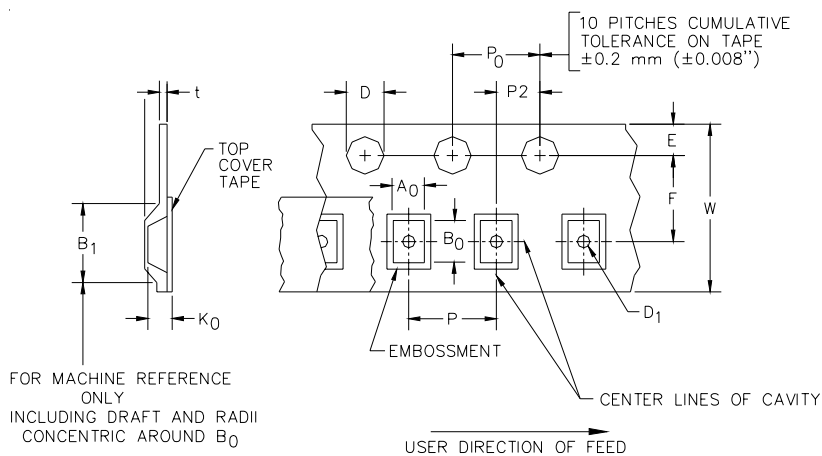

A0	B0	K0
0.69 +/-0.10 mm	1.19 +/-0.10 mm	0.66 +/-0.10 mm

Tape Width	B, (Max)	D	D1	E	F	K (Max)	P	P0	P2	T (Max)	W
8 mm	4.2 mm (.165)	1.5 + 0.1 mm - 0.0 mm (0.59 + .005 - .000)	0.8 mm ±0.25 (.031)	1.750±0.1 mm (.069±.004)	3.5±0.05 mm (.138±.002)	2.4 mm (.094)	4.0±0.10 mm (.157±.004)	4.0±0.1 mm (.157±.004)	2.0±0.05 mm (.079±.002)	0.4mm (.016)	8.0 mm + 0.3 mm - 0.1 mm (.312±.012)

### Contact Information for Semtech International AG

**Taiwan Branch**  
Tel: 886-2-2748-3380  
Fax: 886-2-2748-3390

**Korea Branch**  
Tel: 82-2-527-4377  
Fax: 82-2-527-4376

**Shanghai Office**  
Tel: 86-21-6391-0830  
Fax: 86-21-6391-0831

Semtech International AG is a wholly-owned subsidiary of Semtech Corporation, which has its headquarters in the U.S.A.

**Semtech Switzerland GmbH**  
Tel: 81-3-6408-0950  
Fax: 81-3-6408-0951

**Semtech Japan Branch**  
Tel: 44-1794-527-600  
Fax: 44-1794-527-601

**Semtech Limited (U.K.)**  
Tel: 33-(0)169-28-22-00  
Fax: 33-(0)169-28-12-98

**Semtech France SARM**  
Tel: 49-(0)8161-140-123  
Fax: 49-(0)8161-140-124