

PROTECTION PRODUCTS - RailClamp®

Description

RailClamps® are low capacitance TVS arrays designed to protect high speed data interfaces. This series has been specifically designed to protect sensitive components which are connected to data and transmission lines from overvoltage caused by **ESD** (electrostatic discharge), **CDE** (Cable Discharge Events), and **EFT** (electrical fast transients).

The unique design incorporates surge rated, low capacitance steering diodes and a TVS diode in a single package. During transient conditions, the steering diodes direct the transient current to ground. The internal TVS diode clamps the transient voltage to a safe level. The low capacitance array configuration allows the user to protect up to four high-speed data lines.

The RClamp0504P is in a 6-pin, RoHS compliant, SLP1616P6 package. It measures 1.6 x 1.6 x 0.60mm. The leads are spaced at a pitch of 0.5mm and are finished with lead-free NiPdAu. They may be used to meet the ESD immunity requirements of IEC 61000-4-2, Level 4 (15kV air, 8kV contact discharge). The combination of small size, low capacitance, and high ESD surge capability makes them ideal for use in portable applications such as cellular phones, next generation color LCD displays, USB, and multi media card interfaces.

Features

- ◆ Transient protection for high-speed data lines to **IEC 61000-4-2 (ESD) ±15kV (air), ±8kV (contact) IEC 61000-4-4 (EFT) 40A (5/50ns)**
- ◆ Array of surge rated diodes with internal TVS Diode
- ◆ Small package (1.6 x 1.6mm) saves board space
- ◆ Protects up to four I/O lines & power line
- ◆ Low capacitance (**<3pF**) for high-speed interfaces
- ◆ No insertion loss to **2.0GHz**
- ◆ Low leakage current and clamping voltage
- ◆ Low operating voltage: 5.0V
- ◆ Solid-state silicon-avalanche technology

Mechanical Characteristics

- ◆ SLP1616P6 6L package
- ◆ RoHS/WEEE Compliant
- ◆ Nominal Dimensions: 1.6 x 1.6 x 0.60 mm
- ◆ Lead Finish: NiPdAu
- ◆ Molding compound flammability rating: UL 94V-0
- ◆ Marking : 0504P
- ◆ Packaging : Tape and Reel per EIA 481

Applications

- ◆ USB 2.0 and USB OTG
- ◆ Multi Media Card (MMC) Interfaces
- ◆ SD Card Interfaces
- ◆ MDDI Ports
- ◆ SIM Ports
- ◆ Key Pads
- ◆ Gigabit Ethernet

Circuit Diagram

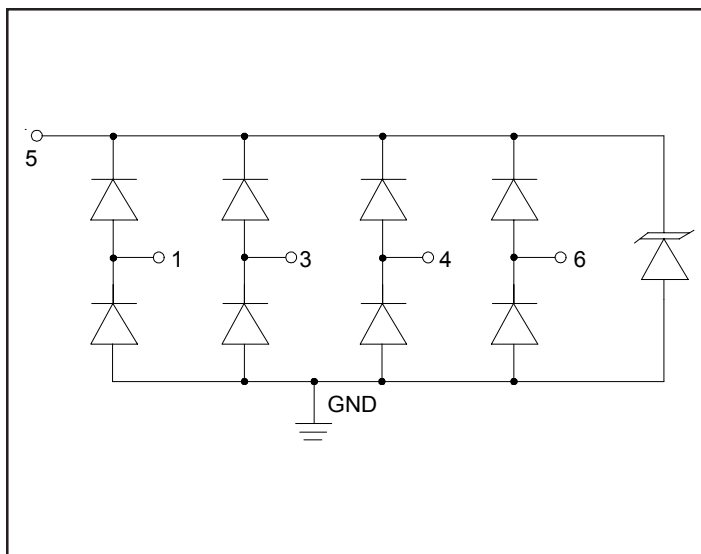

PIN Configuration

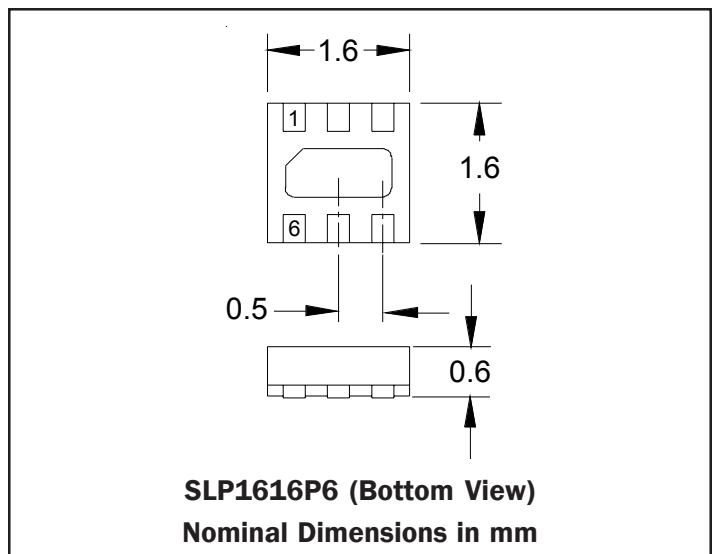

PROTECTION PRODUCTS

Absolute Maximum Rating

Rating	Symbol	Value	Units
Peak Pulse Power (tp = 8/20μs)	P_{pk}	150	Watts
Peak Pulse Current (tp = 8/20μs)	I_{pp}	6	A
ESD per IEC 61000-4-2 (Air) ESD per IEC 61000-4-2 (Contact)	V_{ESD}	15 8	kV
Operating Temperature	T_J	-55 to +125	°C
Storage Temperature	T_{STG}	-55 to +150	°C

Electrical Characteristics (T=25°C)

Parameter	Symbol	Conditions	Minimum	Typical	Maximum	Units
Reverse Stand-Off Voltage	V_{RWM}	Pin 5 to GND			5	V
Reverse Breakdown Voltage	V_{BR}	$I_t = 1mA$ Pin 5 to GND	6			V
Reverse Leakage Current	I_R	$V_{RWM} = 5V, T=25°C$ Pin 5 to GND			3	μA
Clamping Voltage	V_C	$I_{pp} = 1A, tp = 8/20μs$ Any I/O pin to GND			15	V
Clamping Voltage	V_C	$I_{pp} = 6A, tp = 8/20μs$ Any I/O pin to GND			25	V
Clamping Voltage	V_C	$I_{pp} = 6A, tp = 8/20μs$ Pin 5 to GND			18	V
Junction Capacitance	C_j	$V_R = 0V, f = 1MHz$ Any I/O pin to GND		1.9	3	pF
		$V_R = 0V, f = 1MHz$ Between I/O pins		0.80	1	pF

Note 1: I/O pins are pin 1, 3, 4, and 6

PROTECTION PRODUCTS

Typical Characteristics

Non-Repetitive Peak Pulse Power vs. Pulse Time

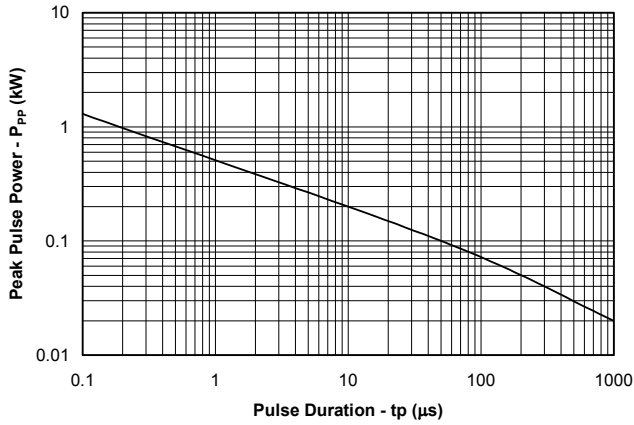

Power Derating Curve

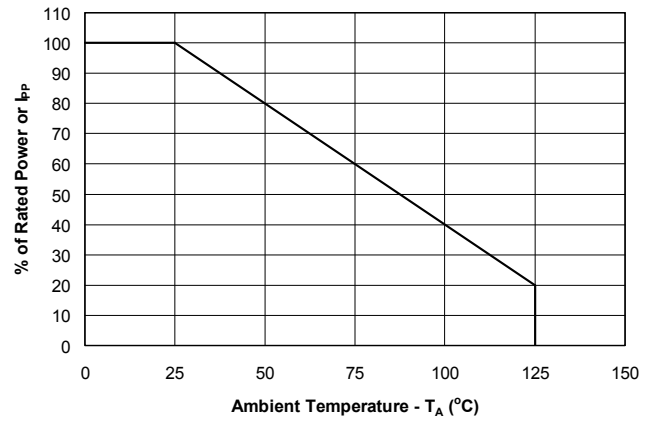

Pulse Waveform

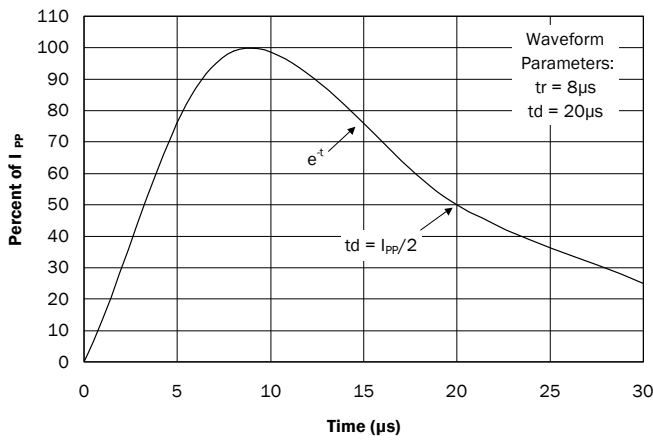

Clamping Voltage vs. Peak Pulse Current

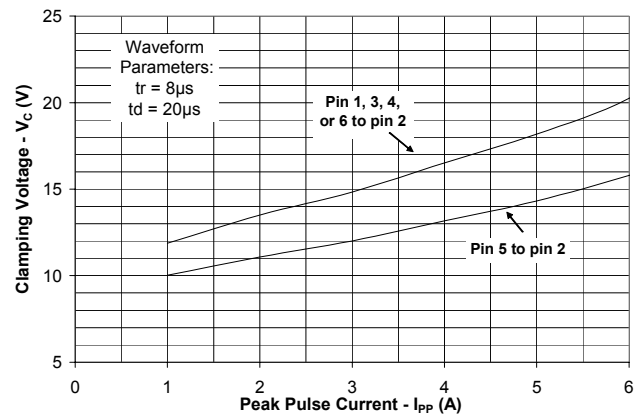

Forward Voltage vs. Peak Pulse Current

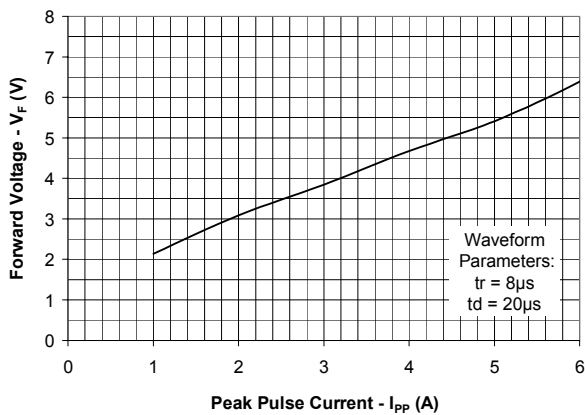

Junction Capacitance vs. Reverse Voltage

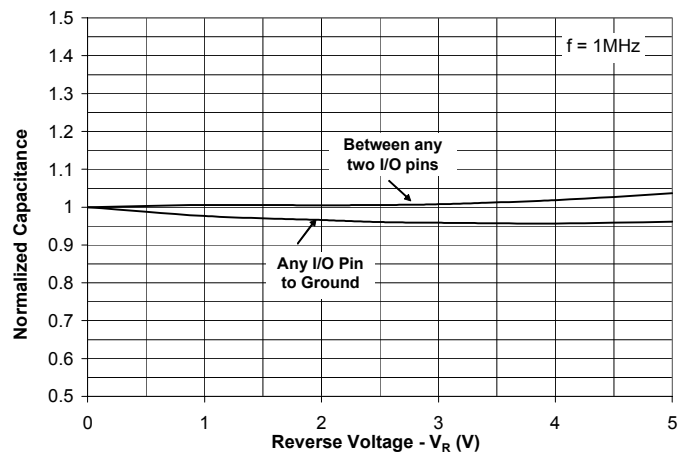

PROTECTION PRODUCTS

Typical Characteristics

Insertion Loss S21 (I/O to Gnd)

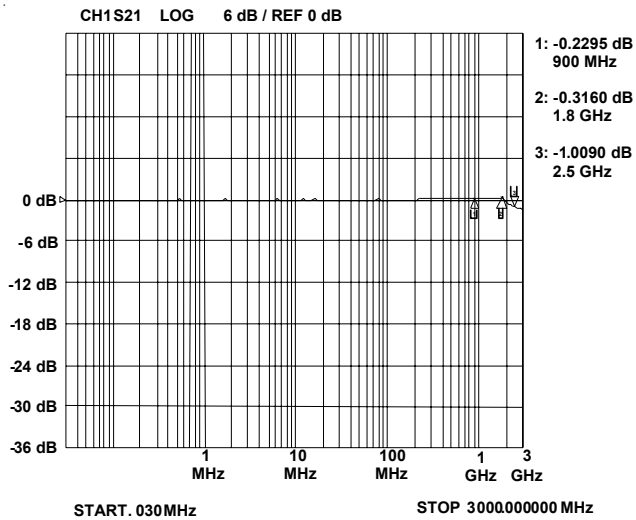

Analog Crosstalk

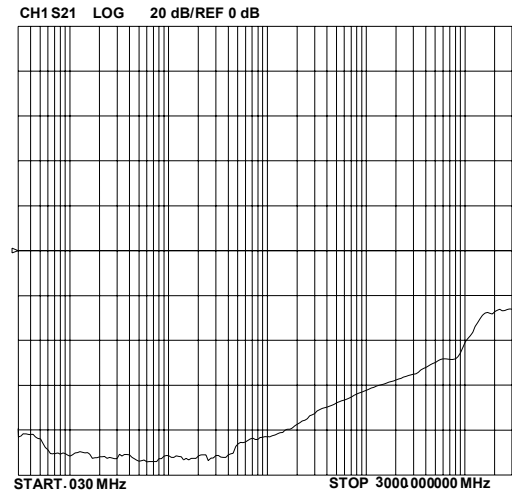

ESD Response (8kV Contact per IEC 61000-4-2)

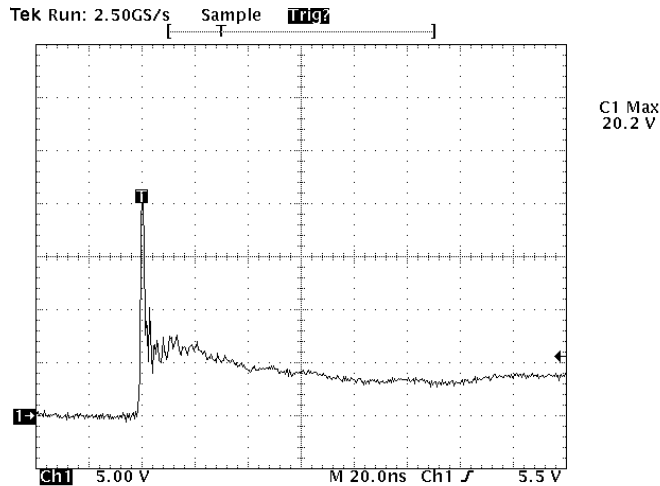

Note: Data is taken with a 10x attenuator

PROTECTION PRODUCTS

Applications Information

Device Connection Options for Protection of Four High-Speed Data Lines

This device is designed to protect data lines by clamping them to a fixed reference. When the voltage on the protected line exceeds the reference voltage the steering diodes are forward biased, conducting the transient current away from the sensitive circuitry. Data lines are connected at pins 1, 3, 4 and 6. The center pin should be connected directly to a ground plane. The path length is kept as short as possible to minimize parasitic inductance. Pin 2 is not connected. The positive reference is connected at pin 5. The options for connecting the positive reference are as follows:

1. To protect data lines and the power line, connect pin 5 directly to the positive supply rail (V_{CC}). In this configuration the data lines are referenced to the supply voltage. The internal TVS diode prevents over-voltage on the supply rail.
2. In applications where the supply rail does not exit the system, the internal TVS may be used as the reference. In this case, pin 5 is not connected. The steering diodes will begin to conduct when the voltage on the protected line exceeds the working voltage of the TVS (plus one diode drop).

Figure 1. Pin Configuration (Top Side View)

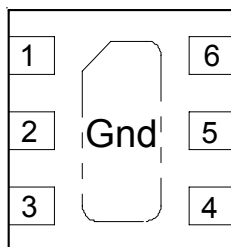

Pin	Identification
1, 3, 4, 6	Input/Output Lines
2	Not Connected
5	5V (Optional) or N/C
Center Tab	Ground

Protection of Four Data Lines and Power Supply Line

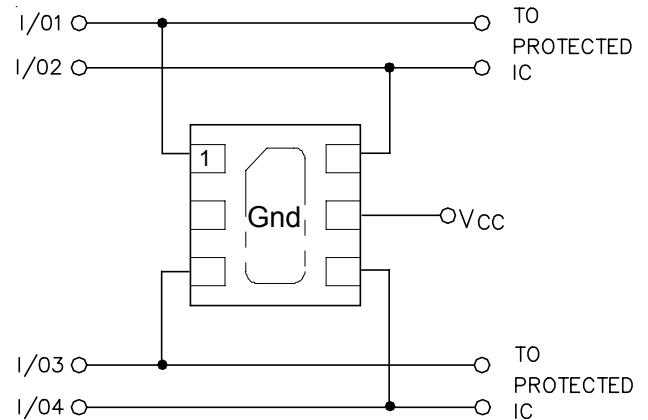

Protection of Four Data Lines Using Internal TVS Diode as Reference

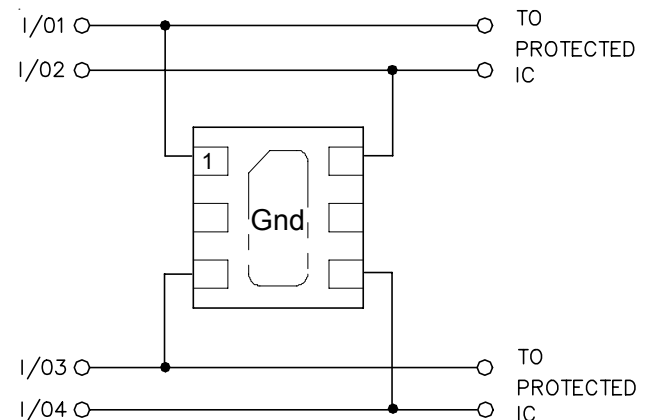

PROTECTION PRODUCTS

Typical Applications

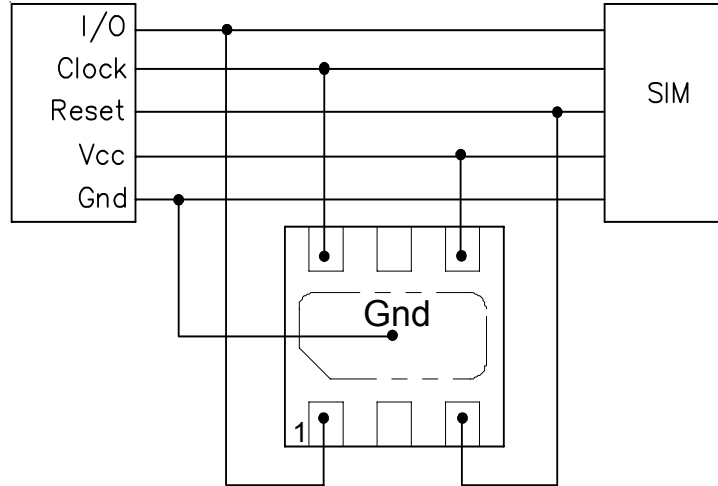

SIM Port - Protection of Three Data Lines and VCC

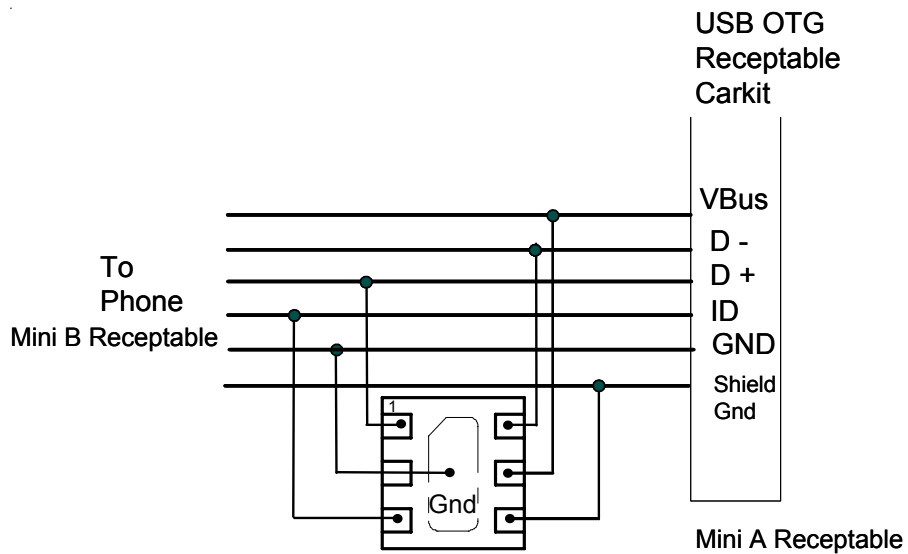

USB OTG CarKit Protection

PROTECTION PRODUCTS

Applications Information - Spice Model

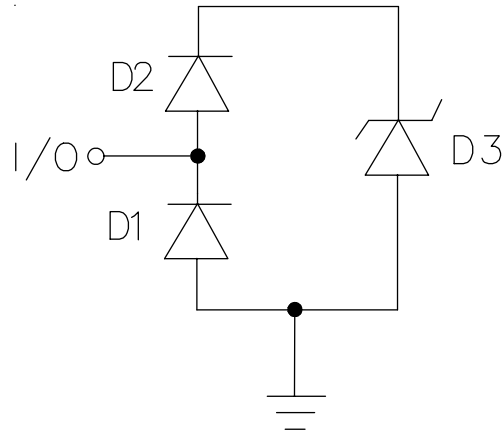
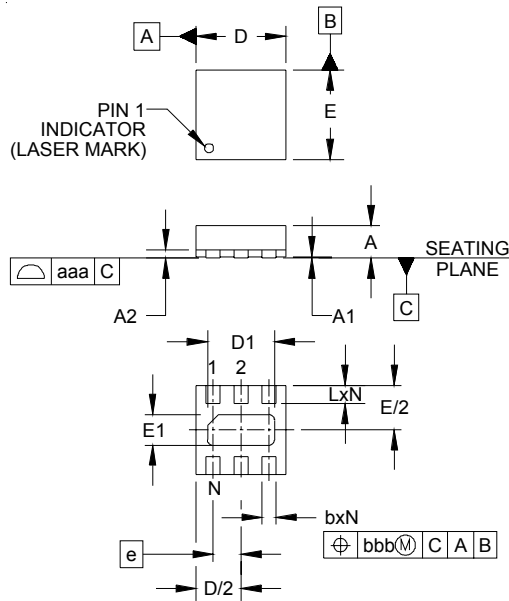

Figure 1 - RClamp0504P Spice Model

Table 1 - RClamp0504P Spice Parameters				
Parameter	Unit	D1 (LCRD)	D2 (LCRD)	D3 (TVS)
IS	Amp	1E-20	1E-20	2.19E-12
BV	Volt	100	100	7.8
VJ	Volt	0.66	0.65	0.57
RS	Ohm	0.314	0.687	1.444
IBV	Amp	1E-3	1E-3	1E-3
CJO	Farad	1.5E-12	1.5E-12	121E-12
TT	sec	2.541E-9	2.541E-9	2.541E-9
M	--	0.01	0.01	0.236
N	--	1.1	1.1	1.1
EG	eV	1.11	1.11	1.11

PROTECTION PRODUCTS

Outline Drawing - SLP1616P6



DIM	INCHES			MILLIMETERS		
	MIN	NOM	MAX	MIN	NOM	MAX
A	.020	.023	.026	0.50	0.58	0.65
A1	0.00	.001	.002	0.00	0.03	0.05
A2		(.006)			(0.15)	
b	.007	.010	.012	0.20	0.25	0.30
D	.059	.063	.067	1.50	1.60	1.70
D1	.041	.047	.051	1.05	1.20	1.30
E	.059	.063	.067	1.50	1.60	1.70
E1	.016	.022	.026	0.40	0.55	0.65
e		.020 BSC			0.50 BSC	
L	.013	.013	.016	0.25	0.33	0.40
N		6			6	
aaa		.004			0.09	
bbb		.004			0.09	

NOTES:

1. CONTROLLING DIMENSIONS ARE IN MILLIMETERS (ANGLES IN DEGREES).
2. COPLANARITY APPLIES TO THE EXPOSED PAD AS WELL AS THE TERMINALS.

Land Pattern - SLP1616P6

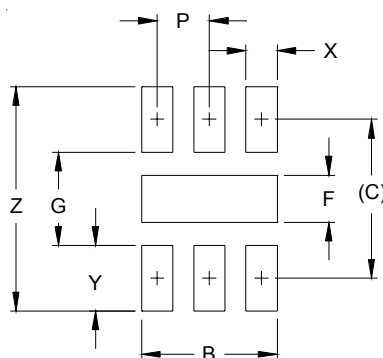

DIM	DIMENSIONS	
	INCHES	MILLIMETERS
B	.051	1.30
C	.060	1.52
P	.020	0.50
F	.018	0.45
G	.035	0.89
X	.012	0.30
Y	.025	0.63
Z	.085	2.15

NOTES:

1. THIS LAND PATTERN IS FOR REFERENCE PURPOSES ONLY.
CONSULT YOUR MANUFACTURING GROUP TO ENSURE YOUR COMPANY'S MANUFACTURING GUIDELINES ARE MET

PROTECTION PRODUCTS

Marking

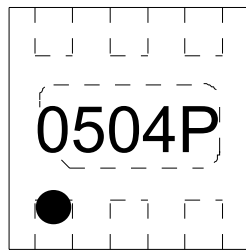

Ordering Information

Part Number	Lead Finish	Qty per Reel	Reel Size
RClamp0504P.TCT	Pb Free	3,000	7 Inch

RailClamp and RClamp are marks of Semtech Corporation

Tape and Reel Specification

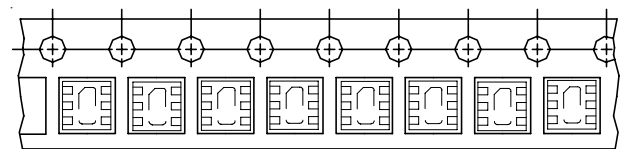
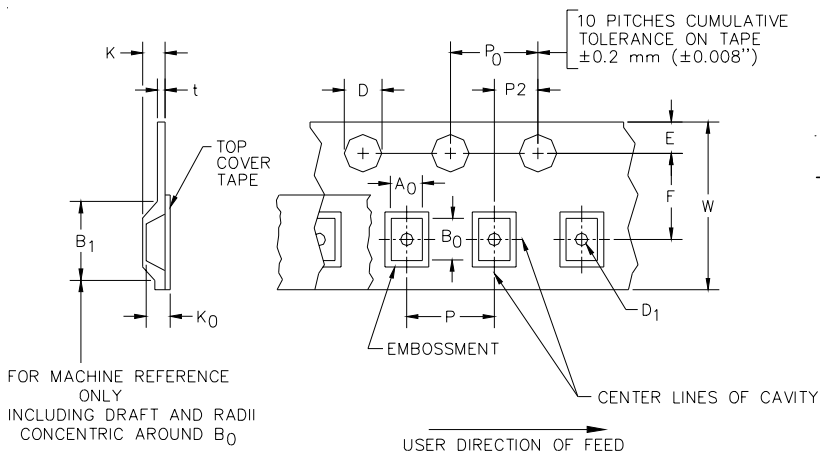

Device Orientation in Tape

A0	B0	K0
1.78 +/-0.05 mm	1.78 +/-0.05 mm	0.69 +/-0.05 mm

Tape Width	B, (Max)	D	D1	E	F	K (MAX)	P	P0	P2	T(MAX)	W
8 mm	4.2 mm	1.5 + 0.1 mm - 0.0 mm)	0.5 mm ±0.05	1.750±.10 mm	3.5±0.05 mm	2.4 mm	4.0±0.1 mm	4.0±0.1 mm	2.0±0.05 mm	0.4 mm	8.0 mm + 0.3 mm - 0.1 mm

Contact Information for Semtech International AG

Taiwan Branch Tel: 886-2-2748-3380
Fax: 886-2-2748-3390

Korea Branch Tel: 82-2-527-4377
Fax: 82-2-527-4376

Shanghai Office Tel: 86-21-6391-0830
Fax: 86-21-6391-0831

Semtech Switzerland GmbH Tel: 81-3-6408-0950
Japan Branch Fax: 81-3-6408-0951

Semtech Limited (U.K.) Tel: 44-1794-527-600
Fax: 44-1794-527-601

Semtech France SARL Tel: 33-(0)169-28-22-00
Fax: 33-(0)169-28-12-98

Semtech Germany GmbH Tel: 49-(0)8161-140-123
Fax: 49-(0)8161-140-124

Semtech International AG is a wholly-owned subsidiary of Semtech Corporation, which has its headquarters in the U.S.A.