

PROTECTION PRODUCTS

Protecting USB Ports from ESD Damage

Since USB is a hot insertion and removal system, USB components are subject to electrostatic discharge (ESD). However, ESD protection is not yet a specific requirement of the USB specification. State-of-the-art USB ICs are manufactured on high integration CMOS processes making them extremely sensitive to damage from the high static voltages associated with an ESD event. Some USB hub chips are internally protected from ESD events ranging from 500V to 2kV. This may provide a false sense of security since IEC 61000-4-2 typically requires commercial equipment pass ESD immunity tests with voltages up to 15kV for air discharge and 8kV for contact discharge. Ten pulses in each polarity are required for each test level. The IEC specification allows all cables to be attached to the equipment during testing. As such, the equipment may pass certain regulatory tests with the shielded USB cable attached. However, by definition USB is a hot plugging bus. When the socket is open, it is vulnerable to a potentially hazardous strike. The user may inject the strike while plugging and unplugging a peripheral device, or by just reaching for a nearby switch. Physical contact with the port is not necessary. An air discharge event can occur several centimeters away from the conducting surface. Damage to the USB interface IC

can occur as a result of the high static potential or from the conducted ESD currents. The resulting damage can be catastrophic or latent. Latent failures manifest themselves long after the ESD event has occurred. Protecting vulnerable USB components with devices designed to handle high energy transients can save time and money. Protecting the USB port is not a straight forward task however. The high data transmission speed and increased sophistication of the USB controller means a more sophisticated protection device must be used. Conventional methods used to protect typical serial ports are rendered useless. An ill chosen scheme can interfere with the normal operation of the USB port.

Devices used to protect USB ports must have the following characteristics :

1. Low capacitance for minimal signal attenuation at the 12Mbps data rate.
2. Extremely fast response time for responding to the sub nanosecond rise time of the ESD pulse.
3. Low clamping and operating voltages for optimum protection of the USB ASIC.
4. Low leakage current for minimal power consumption.

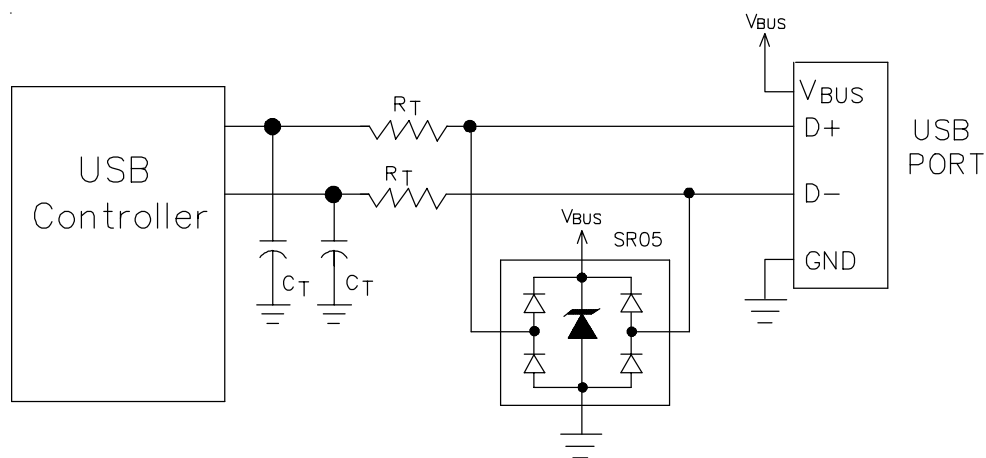

Figure 1 - Single Port USB Protection

PROTECTION PRODUCTS

5. Ability to remain undamaged by repetitive ESD strikes
6. Capacity to handle ESD currents as high as 30A.
7. Minimum package size

USB Protection Topology

Each USB port consists of four lines. Two lines (D+ and D-) are used for bidirectional data transfer, and two lines are reserved for bus voltage and ground. Both USB power and data line connections are vulnerable to ESD strikes. Most protection techniques typically utilize multiple discrete devices, but this is not advisable. Interconnections between discrete components increases the parasitic inductance in the conduction path of the transient current, thus reducing the overall effectiveness of the protection circuit. The Semtech RailClamp™ series provides an easily implemented, cost effective solution for protecting multiple high-speed lines and the power supply line. The RailClamp devices are integrated arrays of low capacitance, surge rated steering diodes and a TVS diode in a single package. The devices are designed to exceed the ESD requirements of IEC 61000-4-2. Figures 1 and 2 illustrate how to use the SR05 to protect one USB port and the SRDA05-4 to protect two USB

ports. When the voltage on the data lines exceed the bus voltage (plus one diode drop), the internal rectifiers are forward biased conducting the transient current away from the protected controller chip. The integrated TVS diode directs the surge to ground. The TVS diode also acts to suppress ESD strikes directly on the voltage bus. Thus, both power and data pins are protected with a single device. The SR05 adds a maximum loading capacitance of 10pF and the SRDA05-4 adds a maximum loading capacitance of 15pF per line. With proper design and layout, the USB port can be protected to >15kV (Human Body Model per IEC 61000-4-2).

References and Further Information

- Universal Serial Bus Specification, Revision 1.0, January 15, 1996
- USB Implementers Forum Web Site: www.usb.org

RailClamp is a registered trademark of Semtech Corporation

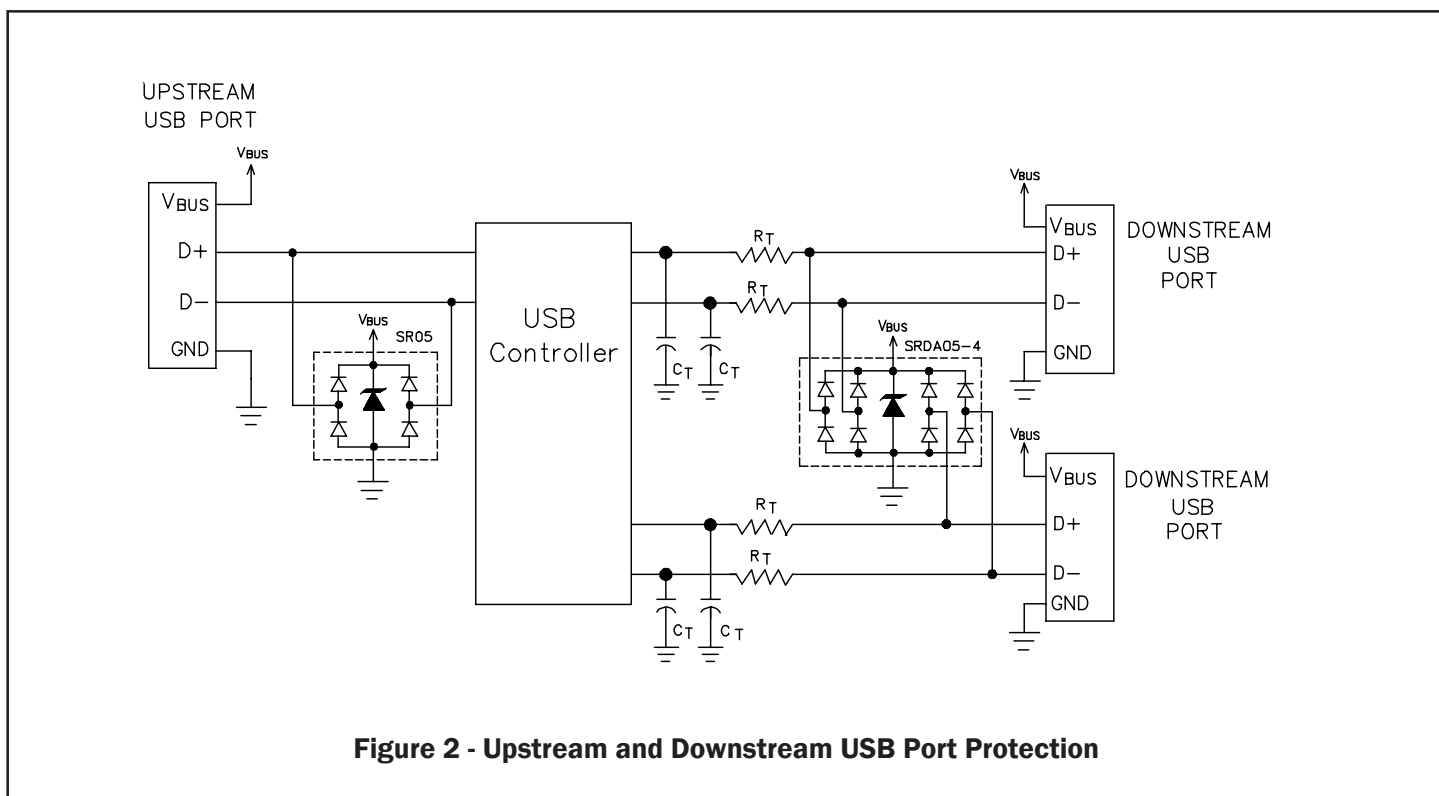

Figure 2 - Upstream and Downstream USB Port Protection