

# Product Brief



## Power Management Solutions for Altera® FPGAs

**Semtech offers design solutions for core voltage and I/O system requirements of Stratix® and Cyclone™ FPGA families.**

**Field Programmable Gate Arrays (FPGA)** are used in a vast variety of ways and therefore require power levels that vary considerably. Several factors determine FPGA power usage including: FPGA type, operating frequency, temperature, I/O usage and characteristics, and the percentage of the FPGA resources utilized. For in depth FPGA power consumption details please visit the Altera website for their Altera FPGA power calculator tools. This product brief features Semtech Power management solutions for the Stratix and Cyclone family of FPGA devices.

### Important design considerations for powering FPGAs:

- Soft-start
- Enable
- Fast Transient Response
- Frequency Synchronization
- Interleaved Phase Switching

FPGA supply types for the latest Stratix III family require a selectable core voltage supply (VCCL) of 0.9V or 1.1V. All other devices in the Stratix and Cyclone families have a fixed core voltage supply and separate supply requirements for I/O, reference voltage, termination resistors, and auxiliary functions.

### Stratix III Power Supply Requirements:

Power Requirement	Power Solution
V <sub>CCL</sub> : Selectable Core Voltage (0.9V or 1.1V)	Switching Regulator
V <sub>CC</sub> : I/O Registers Power Supply (Fixed 1.1V)	Switching or Linear Regulator
V <sub>CCIO</sub> : I/O Power Supply (1.2V, 1.8V, 2.5V, or 3.0V)	Switching or Linear Regulator
V <sub>CCPD</sub> : Pre-driver Power Supply (3.0V or 2.5V)	Switching or Linear Regulator
V <sub>CCPT</sub> : Programmable Power Technology Power Supply (Fixed 2.5V)	Switching or Linear Regulator
V <sub>CCPGM</sub> : Configuration Pins Power (Fixed 1.8V, 2.5V, or 3.0V)	Switching or Linear Regulator
V <sub>REF</sub> : Power Supply for the Voltage Referenced I/O Standards	Voltage Reference

# Product Brief

## Reference Design Example

This reference design illustrates typical power management design requirements incorporating Semtech solutions for powering the Stratix III FPGA from the Stratix FPGA family. The following steps are recommended for selection of the optimal Semtech solution(s) for your FPGA power management system.

**Step 1.** Estimate the required FPGA frequency and select the appropriate FPGA product type

**Step 2.** Estimate the power requirements for each of the Stratix III power supplies using Altera's web power tool for the Stratix III family.

<http://www.altera.com/support/devices/estimator/pow-powerplay.jsp>

**Step 3.** From step 2 the following power requirements have been determined (see design below)

- Input supply = 12V VDC
- $V_{CCL} = 1.1V, I_{CCL} \geq 15A^{(1)}$
- $V_{CC} = 1.1V, I_{CC} \geq 8A^{(1)}$
- $V_{CCIO} = 1.2V, I_{CCIO} \geq 2.5A^{(1)}$
- $V_{CCPD} = 2.5V, I_{CCPD} \geq 500mA^{(1)}$

**Step 4.** Once the FPGA voltages and current values are known, a converter type can be chosen. There are two main types of solutions used for powering FPGA: linear regulators and switching regulators. Both regulator types step down a voltage from a higher level to a lower level. Only switching regulators step up the input voltage from a lower level to a higher level. When choosing between the two regulator types, system efficiency, power loss, and junction temperature are important factors to consider. Given the requirements from step 3, a switching regulator topology featuring devices SC2441A<sup>(2)(3)(4)</sup> and SC2544<sup>(2)(3)(4)</sup> was implemented. This design was done using the SC2441A<sup>(2)(3)(4)</sup> and SC2544<sup>(2)(3)(4)</sup>.

Use the Selection Tables, "Altera FPGA Core Voltage" and "Altera FPGA I/O Voltage," on pages 3 and 4 to select other compatible solutions.

(1) Values are dependent upon the type of Stratix III FPGA, number of gates used, and clock frequency.

(2) SC2441A is a high efficiency Step-up/down controller. SC2544 is a high performance wide input range dual synchronous buck controller.

(3) Refer to the SC2441A and SC2544 datasheets for individual circuit details, example designs, layout hints, and performance details.

(4) See the Semtech datasheets for component values, detailed regulator designs, and easy to use formulas for calculating L, C, R1, R2, and compensation filters.

## High Level Block Diagram

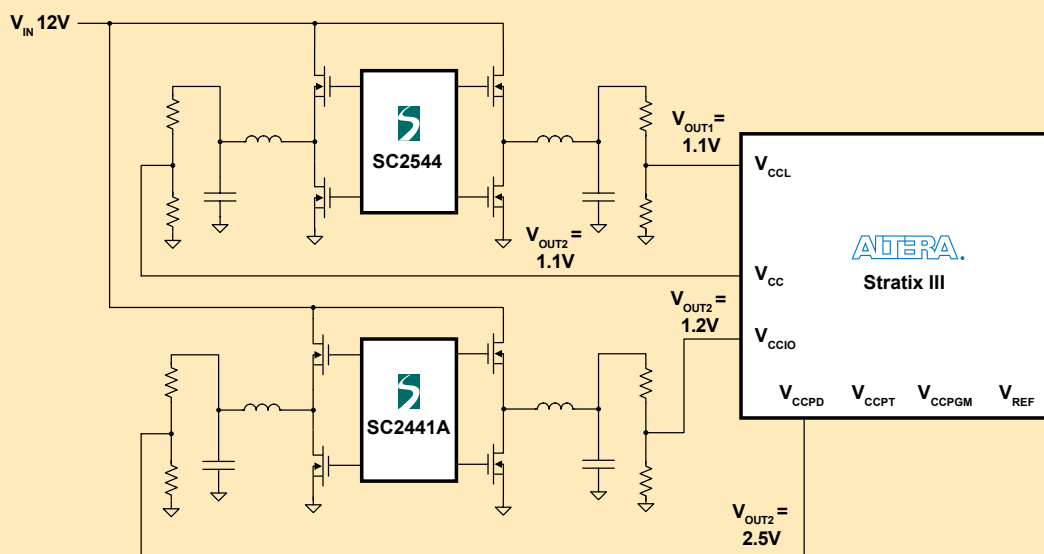

# Product Brief

## Power Management Selection Tables Altera FPGA Core Voltage

### Semtech Power Solutions for Stratix III

Vcore: 0.9V or 1.1V

Vin Range (V)	<500mA	500mA - 2A	2A-5A	5A-15A	<25A
>1.8V	SC4211, SC2441A	SC2441A, SC4211, SC4215A	SC1592, SC2441A	SC2441A	SC2441A
2.5V-5.0V	SC192, SC191A	SC198(A), SC196	SC4624A, SC1592, SC4603, SC339	SC4607, SC4608	SC2441A
<12V	SC4524B	SC4524B, SC2621A,	SC4524B, SC2618, SC338(A)	SC2618, SC2608A, SC4510	SC2602L, SC2441A, SC4510, SC2443
<30V	SC2463	SC2463, SC4524A, SC4525A	SC4524A, SC4525A	SC415, SC475A SC2544, SC2442H	SC2463, SC4612

### Semtech Power Solutions for Stratix II, Stratix II GX, Cyclone II, Cyclone III

Vcore: 1.2V

Vin Range (V)	<500mA	500mA - 2A	2A-5A	5A-15A	<25A
>1.8V	SC1563, SC4211, SC2441A	SC2441A, SC4211, SC4215A, SC1565	SC1592, SC2441A	SC2441A	SC2441A
2.5V-5.0V	SC191A, SC192	SC194A, SC196A, SC198(A)	SC4603, SC4205, SC4624A, SC339	SC4607, SC4608	SC2441A
<12V	SC4524B	SC4524B, SC2440, SC2620	SC4524B, SC2618, SC338(A)	SC2608A, SC4508A, SC4510, SC2618	SC2602L, SC2441A, SC4510, SC2443
<30V	SC2463	SC2463, SC4524A, SC4525A	SC4525A, SC4524A	SC415, SC475A, SC2442H, SC2544	SC2442, SC2463, SC4612

### Semtech Power Solutions for Stratix, Stratix GX, Cyclone

Vcore: 1.5V

Vin Range (V)	<500mA	500mA - 2A	2A-5A	5A-15A	<25A
>1.8V	SC1563, SC4211, SC2441A	SC2441A, SC4211, SC4215A, SC1565	SC1592, SC2441A	SC2441A	SC2441A
2.5V-5.0V	SC194A, SC190B, SC1564, SC192	SC196, SC198(A)	SC4603, SC4624A, SC339	SC4607, SC4608	SC2441A
<12V	SC4524B	SC4524B, SC2440, SC2620	SC4524B, SC2618, SC338(A)	SC2608A, SC4508A, SC4510, SC2618	SC2602L, SC2441A, SC4510, SC2443
<30V	SC2463	SC2463, SC4524A, SC4525A	SC4525A, SC4524A	SC2442H, SC2544, SC2545, SC475(A)	SC2442, SC2463, SC4612

# Product Brief

## Power Management Selection Tables Altera FPGA I/O Voltage

Semtech Power Solutions for Stratix Family and Cyclone Family						
Vcc I/O	Vin	<500mA	500mA - 2A	2A-5A	5A-15A	<25A
1.5V	>1.8V	SC1563, SC4211, SC553, SC2441A	SC4211, SC4215A, SC2441A	SC1592, SC1566, SC2441A	SC2441A	SC2441A
	2.5-5.0V	SC190B, SC192, SC198(A), SC1564	SC1564, SC4624A, SC194A, SC196	SC4624A, SC4603, SC1566, SC339	SC4607, SC4608	SC2441A
	<12V	SC4524B	SC4524B, SC2440, SC2620	SC4524B, SC338(A)	SC4510, SC2608A, SC2618, SC2602L	SC2446, SC2447, SC4614, SC2441A
	<30V	SC2463	SC2620, SC4524A, SC4525A	SC4524A, SC4525A	SC2544, SC2545	SC2463, SC4612
1.8V	>1.8V	SC1563, SC553, SC4211, SC2441A	SC4211, SC4215A, SC4205, SC2441A	SC1592, SC2441A	SC2441A	SC2441A
	2.5-5.0V	SC192, SC198(A), SC190A/B	SC194A, SC196A, SC196, SC4624A	SC4603, SC4624A, SC1566, SC339	SC4607, SC4608	SC2441A
	<12V	SC4524B	SC4524B, SC2440, SC2620	SC4524B, SC2618, SC338(A)	SC4510, SC2608A, SC4508A, SC2602L	SC2446, SC2447, SC4614, SC2441A
	<30V	SC2463	SC2620, SC4524A, SC4525A	SC4524A, SC4525A	SC4510, SC2545, SC2544	SC2463, SC4612
2.5V	>1.8V	SC1563, SC553, SC4211, SC2441A	SC4211, SC4215A, SC4205, SC2441A	SC1592, SC1566, SC2441A	SC2441A	SC2441A
	2.5-5.0V	SC198A, SC190C, SC1564, SC192	SC194B, SC196, SC4624A, SC1564	SC4603, SC4624A, SC1566, SC339	SC4607, SC4608	SC2441A
	<12V	SC4524B	SC2440, SC2620, SC4524B	SC4524B, SC2618, SC338(A)	SC4510, SC2608A, SC2602L, SC4508A	SC2446, SC2447, SC4614, SC2441A
	<30V	SC2463	SC2620, SC4524A, SC4525A	SC4524A	SC4510, SC2544, SC2545	SC2463, SC4612
3.3V	>1.8V	SC1563, SC553, SC4211, SC2441A	SC4211, SC4215A, SC2441A	SC1592, SC1566, SC2441A	SC2441A	SC2441A
	2.5-5.0V	SC192, SC198A, SC1564	SC194B, SC196, SC4624A, SC1564	SC4603, SC4624A, SC1566, SC339	SC4607, SC4608	SC2441A
	<12V	SC4524B	SC2440, SC2620, SC4524B	SC4524B, SC2618, SC338(A)	SC4510, SC2602L, SC2608A, SC4508A	SC2446, SC2447, SC4614, SC2441A
	<30V	SC2463	SC2620 SC4524A, SC4525A	SC4524A, SC4525A	SC2545, SC2442H	SC2463, SC4612

Altera, Stratix and Cyclone are trademarks of Altera Corporation, which are registered in the U.S. Pat. & TM Office.