

PROTECTION PRODUCTS

Description

The LCDA series of TVS arrays are designed to protect sensitive electronics from damage or latch-up due to ESD and other voltage-induced transient events. Each device will protect two high-speed lines. They are available with operating voltages of 5V, 12V, 15V and 24V. They are bidirectional devices and may be used on lines where the signal polarities are above and below ground.

TVS diodes are solid-state devices designed specifically for transient suppression. They offer desirable characteristics for board level protection including fast response time, low operating and clamping voltage and no device degradation. The LCDA series devices feature low capacitance compensation diodes in series with standard TVS diodes to provide an integrated, low capacitance solution for use on high-speed interfaces.

The LCDA series devices may be used to meet the immunity requirements of IEC 61000-4-2, level 4.

Features

- ◆ Transient protection for high-speed data lines to **IEC 61000-4-2 (ESD) $\pm 15\text{kV}$ (air), $\pm 8\text{kV}$ (contact)**
- ◆ **IEC 61000-4-4 (EFT) 40A (5/50ns)**
- ◆ **IEC 61000-4-5 (Lightning) (8/20 μs)***
- ◆ Protects two I/O lines
- ◆ Low capacitance for high-speed data lines
- ◆ Working voltages: 5V, 12V, 15V and 24V
- ◆ Low leakage current
- ◆ Low operating and clamping voltages
- ◆ Solid-state silicon avalanche technology

Mechanical Characteristics

- ◆ JEDEC SO-8 package
- ◆ Molding compound flammability rating: UL 94V-0
- ◆ Marking : Part Number, Date Code
- ◆ Packaging : Tape and Reel per EIA 481

Applications

- ◆ High-Speed Data Lines
- ◆ Microprocessor Based Equipment
- ◆ Universal Serial Bus (USB) Port Protection
- ◆ Notebooks, Desktops, and Servers
- ◆ Instrumentation
- ◆ LAN/WAN Equipment
- ◆ Peripherals

*See Electrical Characteristics Tables for Ipp

Circuit Diagram (Each Line Pair)

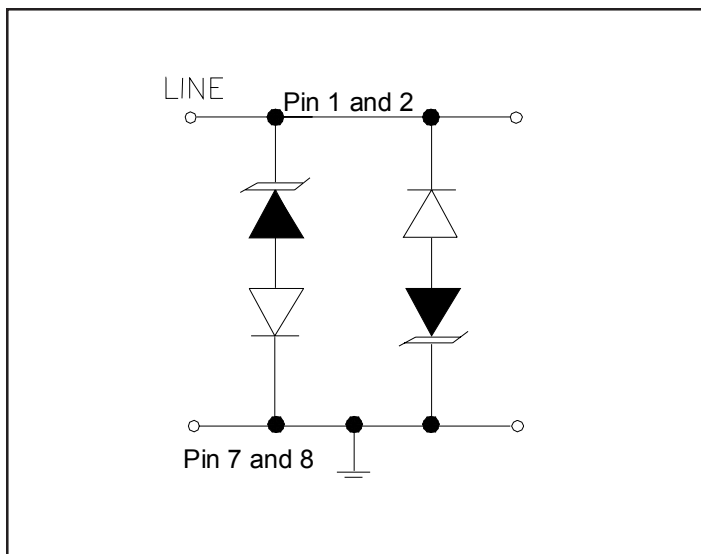

Schematic & PIN Configuration

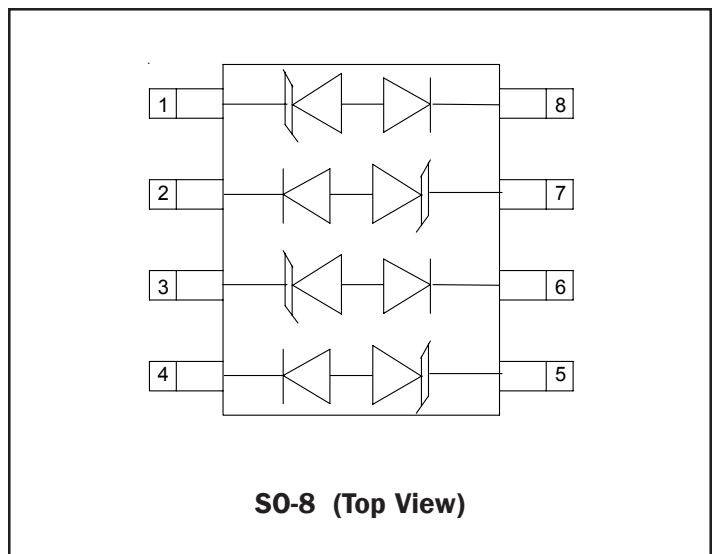

PROTECTION PRODUCTS

Absolute Maximum Rating

Rating	Symbol	Value	Units
Peak Pulse Power ($t_p = 8/20\mu s$)	P_{pk}	300	Watts
Lead Soldering Temperature	T_L	260 (10 sec.)	$^{\circ}C$
Operating Temperature	T_J	-55 to +125	$^{\circ}C$
Storage Temperature	T_{STG}	-55 to +150	$^{\circ}C$

Electrical Characteristics

LCDA05						
Parameter	Symbol	Conditions	Minimum	Typical	Maximum	Units
Reverse Stand-Off Voltage	V_{RWM}				5	V
Reverse Breakdown Voltage	V_{BR}	$I_t = 1mA$	6			V
Reverse Leakage Current	I_R	$V_{RWM} = 5V, T=25^{\circ}C$			20	μA
Clamping Voltage	V_C	$I_{PP} = 1A, t_p = 8/20\mu s$			9.8	V
Clamping Voltage	V_C	$I_{PP} = 5A, t_p = 8/20\mu s$			11	V
Maximum Peak Pulse Current	I_{PP}	$t_p = 8/20\mu s$			17	A
Junction Capacitance	C_j	Between I/O Pins and Ground $V_R = 0V, f = 1MHz$			5	pF

LCDA12						
Parameter	Symbol	Conditions	Minimum	Typical	Maximum	Units
Reverse Stand-Off Voltage	V_{RWM}				12	V
Reverse Breakdown Voltage	V_{BR}	$I_t = 1mA$	13.3			V
Reverse Leakage Current	I_R	$V_{RWM} = 12V, T=25^{\circ}C$			1	μA
Clamping Voltage	V_C	$I_{PP} = 1A, t_p = 8/20\mu s$			19	V
Clamping Voltage	V_C	$I_{PP} = 5A, t_p = 8/20\mu s$			24	V
Maximum Peak Pulse Current	I_{PP}	$t_p = 8/20\mu s$			12	A
Junction Capacitance	C_j	Between I/O Pins and Ground $V_R = 0V, f = 1MHz$			5	pF

PROTECTION PRODUCTS

Electrical Characteristics (continued)

LCDA15						
Parameter	Symbol	Conditions	Minimum	Typical	Maximum	Units
Reverse Stand-Off Voltage	V_{RWM}				15	V
Reverse Breakdown Voltage	V_{BR}	$I_t = 1mA$	16.7			V
Reverse Leakage Current	I_R	$V_{RWM} = 15V, T=25^{\circ}C$			1	μA
Clamping Voltage	V_C	$I_{PP} = 1A, t_p = 8/20\mu s$			24	V
Clamping Voltage	V_C	$I_{PP} = 5A, t_p = 8/20\mu s$			30	V
Maximum Peak Pulse Current	I_{PP}	$t_p = 8/20\mu s$			10	A
Junction Capacitance	C_J	Between I/O Pins and Ground $V_R = 0V, f = 1MHz$			5	pF

LCDA24						
Parameter	Symbol	Conditions	Minimum	Typical	Maximum	Units
Reverse Stand-Off Voltage	V_{RWM}				24	V
Reverse Breakdown Voltage	V_{BR}	$I_t = 1mA$	26.7			V
Reverse Leakage Current	I_R	$V_{RWM} = 24V, T=25^{\circ}C$			1	μA
Clamping Voltage	V_C	$I_{PP} = 1A, t_p = 8/20\mu s$			43	V
Clamping Voltage	V_C	$I_{PP} = 5A, t_p = 8/20\mu s$			55	V
Maximum Peak Pulse Current	I_{PP}	$t_p = 8/20\mu s$			5	A
Junction Capacitance	C_J	Between I/O Pins and Ground $V_R = 0V, f = 1MHz$			5	pF

PROTECTION PRODUCTS

Typical Characteristics

Non-Repetitive Peak Pulse Power vs. Pulse Time

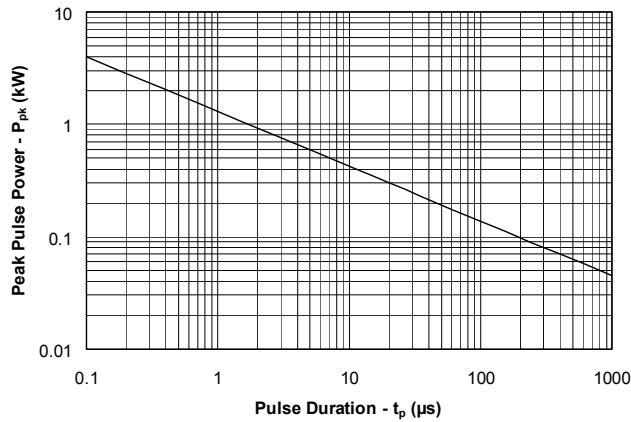

Power Derating Curve

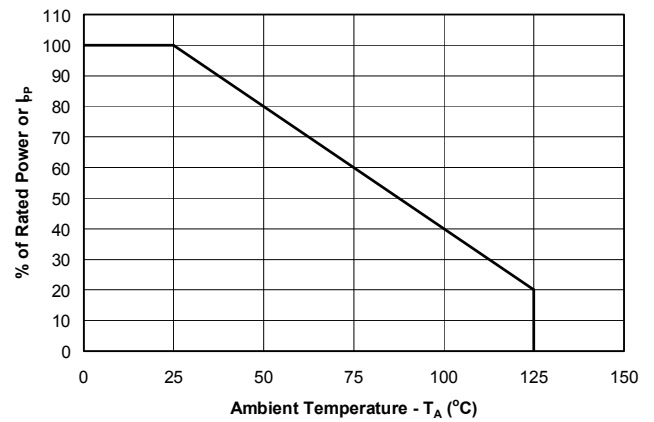

Pulse Waveform

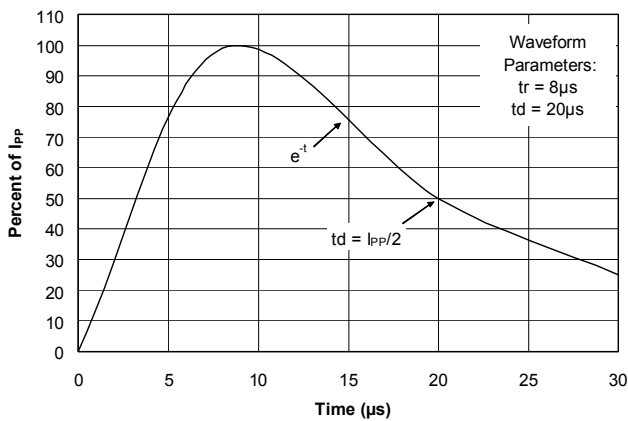

ESD Pulse Waveform (Per IEC 61000-4-2)

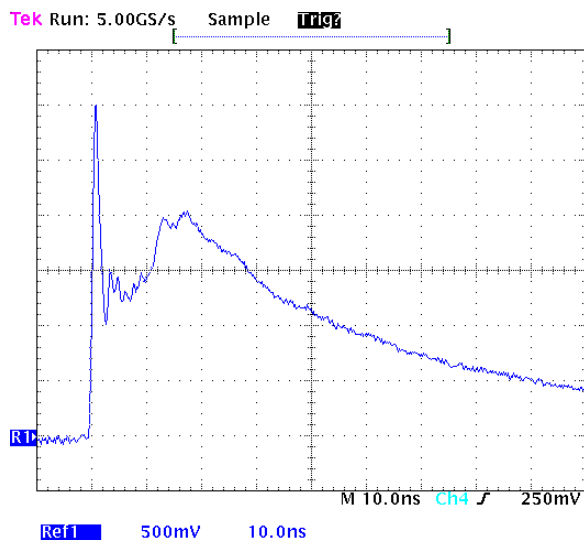

ESD Discharge Parameters Per IEC 61000-4-2

Level	First Peak Current (A)	Peak Current at 30ns (A)	Peak Current at 60ns (A)	Test Voltage (Contact Discharge) (kV)	Test Voltage (Air Discharge) (kV)
1	7.5	4	8	2	2
2	15	8	4	4	4
3	22.5	12	6	6	8
4	30	16	8	8	15

PROTECTION PRODUCTS

Applications Information

Device Connection for Protection of Two High-Speed Data Lines

The LCDAx is designed to protect up to two high-speed data lines. The LCDAx utilizes a low capacitance compensation diode in series with, but in opposite polarity to a TVS diode in each line. The resulting capacitance is less than 5pF per line. Each line will only suppress transient events in one polarity. Therefore, to achieve protection in both positive and negative polarity, a second TVS/rectifier pair is connected in anti-parallel to the first. Pins 1, 2, 7, and 8 are used to protect one data line. Pins 3, 4, 5, and 6 are used to protect the second data line.

The device is connected as follows:

- Pins 1 and 2 are tied together and pins 7 and 8 are tied together providing the protection circuit for one I/O line. Pins 3 and 4 are tied together and pins 5 and 6 are tied together providing the protection circuit for the second I/O line. Since the device is electrically symmetrical, either side of the connected pairs may be used to protect the lines. The other side of the pair is used to make the ground connection. The ground connections should be made directly to the ground plane for best results. The path length is kept as short as possible to reduce the effects of parasitic inductance in the board traces.

Circuit Board Layout Recommendations for Suppression of ESD.

Good circuit board layout is critical for the suppression of ESD induced transients. The following guidelines are recommended:

- Place the TVS near the input terminals or connectors to restrict transient coupling.
- Minimize the path length between the TVS and the protected line.
- Minimize all conductive loops including power and ground loops.
- The ESD transient return path to ground should be kept as short as possible.
- Never run critical signals near board edges.
- Use ground planes whenever possible.

LCDA Connection Diagram

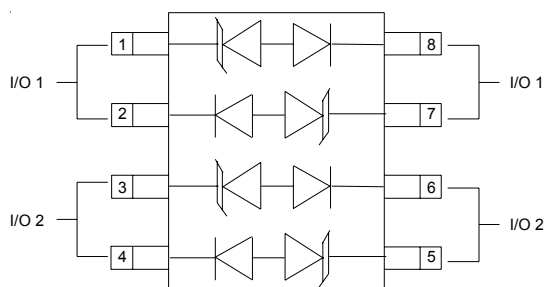

I/O Line Protection

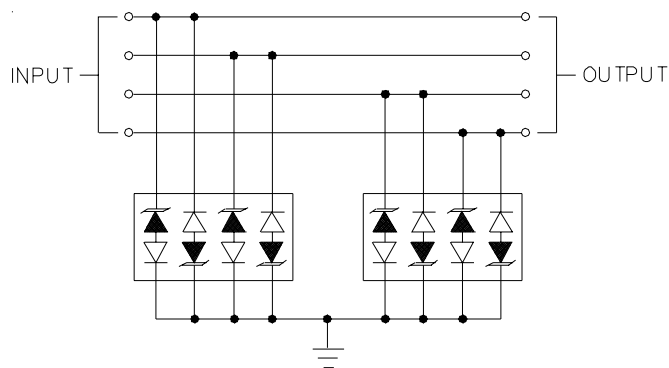

Connection Options

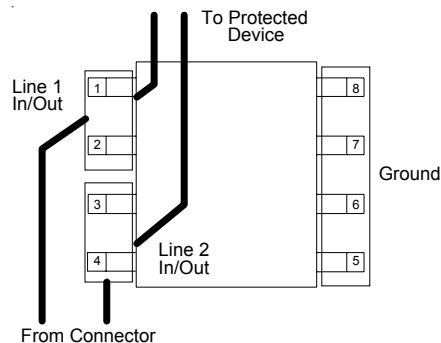
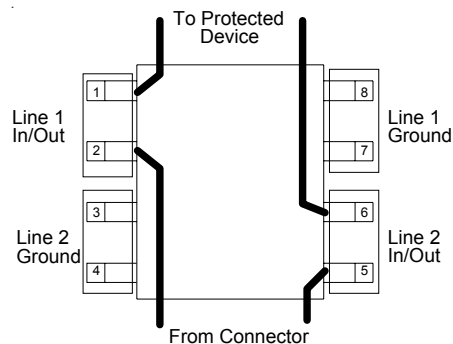

PROTECTION PRODUCTS**Applications Information (*continued*)****Matte Tin Lead Finish**

Matte tin has become the industry standard lead-free replacement for SnPb lead finishes. A matte tin finish is composed of 100% tin solder with large grains. Since the solder volume on the leads is small compared to the solder paste volume that is placed on the land pattern of the PCB, the reflow profile will be determined by the requirements of the solder paste. Therefore, these devices are compatible with both lead-free and SnPb assembly techniques. In addition, unlike other lead-free compositions, matte tin does not have any added alloys that can cause degradation of the solder joint.

PROTECTION PRODUCTS

Outline Drawing - S0-8

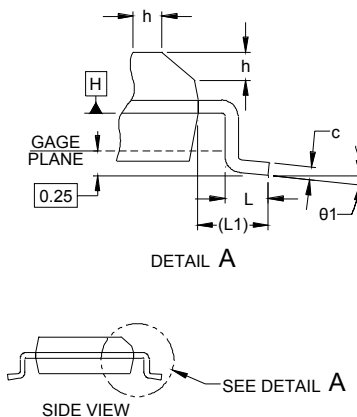
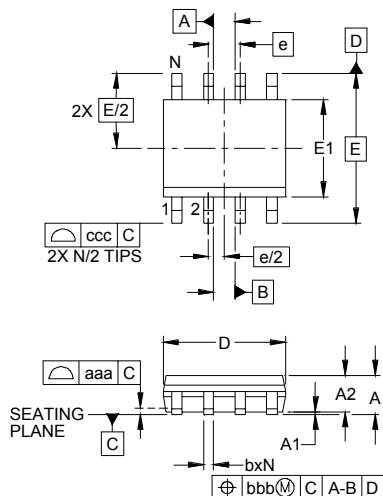

DIM	DIMENSIONS					
	INCHES			MILLIMETERS		
	MIN	NOM	MAX	MIN	NOM	MAX
A	.053	-	.069	1.35	-	1.75
A1	.004	-	.010	0.10	-	0.25
A2	.049	-	.065	1.25	-	1.65
b	.012	-	.020	0.31	-	0.51
c	.007	-	.010	0.17	-	0.25
D	.189	.193	.197	4.80	4.90	5.00
E1	.150	.154	.157	3.80	3.90	4.00
E	.236 BSC			6.00 BSC		
e	.050 BSC			1.27 BSC		
h	.010	-	.020	0.25	-	0.50
L	.016	.028	.041	0.40	0.72	1.04
L1	(0.041)			(1.04)		
N	8			8		
theta1	0°	-	8°	0°	-	8°
aaa	.004			0.10		
bbb	.010			0.25		
ccc	.008			0.20		

NOTES:

1. CONTROLLING DIMENSIONS ARE IN MILLIMETERS (ANGLES IN DEGREES).
2. DATUMS **-A-** AND **-B-** TO BE DETERMINED AT DATUM PLANE **-H-**
3. DIMENSIONS "E1" AND "D" DO NOT INCLUDE MOLD FLASH, PROTRUSIONS OR GATE BURRS.
4. REFERENCE JEDEC STD MS-012, VARIATION AA.

Land Pattern - S0-8

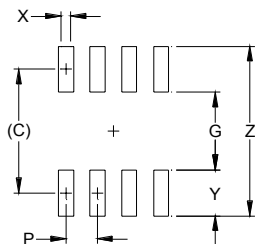

DIM	DIMENSIONS	
	INCHES	MILLIMETERS
C	(.205)	(5.20)
G	.118	3.00
P	.050	1.27
X	.024	0.60
Y	.087	2.20
Z	.291	7.40

NOTES:

1. THIS LAND PATTERN IS FOR REFERENCE PURPOSES ONLY. CONSULT YOUR MANUFACTURING GROUP TO ENSURE YOUR COMPANY'S MANUFACTURING GUIDELINES ARE MET.
2. REFERENCE IPC-SM-782A, RLP NO. 300A.

PROTECTION PRODUCTS

Ordering Information

Part Number	Lead Finish	Qty per Reel	Reel Size
LCDA05.TB	SnPb	500	7 Inch
LCDA12.TB	SnPb	500	7 Inch
LCDA15.TB	SnPb	500	7 Inch
LCDA24.TB	SnPb	500	7 Inch
LCDA05.TBT	Pb Free	500	7 inch
LCDA12.TBT	Pb Free	500	7 inch
LCDA15.TBT	Pb Free	500	7 inch
LCDA24.TBT	Pb Free	500	7 inch
LCDA05	SnPb	95/Tube	N/A
LCDA12	SnPb	95/Tube	N/A
LCDA15	SnPb	95/Tube	N/A
LCDA24	SnPb	95/Tube	N/A
LCDA05.T	Pb Free	95/Tube	N/A
LCDA12.T	Pb Free	95/Tube	N/A
LCDA15.T	Pb Free	95/Tube	N/A
LCDA24.T	Pb Free	95/Tube	N/A

Contact Information for Semtech International AG

Taiwan Branch	Tel: 886-2-2748-3380 Fax: 886-2-2748-3390	Semtech Switzerland GmbH Japan Branch	Tel: 81-3-6408-0950 Fax: 81-3-6408-0951
Korea Branch	Tel: 82-2-527-4377 Fax: 82-2-527-4376	Semtech Limited (U.K.)	Tel: 44-1794-527-600 Fax: 44-1794-527-601
Shanghai Office	Tel: 86-21-6391-0830 Fax: 86-21-6391-0831	Semtech France SARL	Tel: 33-(0)169-28-22-00 Fax: 33-(0)169-28-12-98
Semtech International AG is a wholly-owned subsidiary of Semtech Corporation, which has its headquarters in the U.S.A.		Semtech Germany GmbH	Tel: 49-(0)8161-140-123 Fax: 49-(0)8161-140-124