

PROTECTION PRODUCTS

Electrostatic Discharge (ESD) Protection for Ethernet Transceivers

This application note illustrates how to implement ESD protection for Ethernet transceivers. The protection technique shown may be used to aid in meeting the test requirements of IEC 61000-4-2. This type of protection may be used to prevent damage to transceivers which interface the Ethernet coaxial LAN to the DTE or PC.

IEC 61000-4-2 defines ESD immunity requirements for equipment which is shipped into the European Community. The standard defines test voltages as high as 15kV for air discharge (8 kV contact discharge) and induced current as high as 30A. The test procedure requires that equipment be able to withstand ten pulses in both positive and negative polarity.

An electrostatic discharge to the shield of the coaxial connector causes an electromagnetic wave to propagate across the transceiver board interface to the circuit board. The wave travel along the metal traces which connect the shield to the PC board ground plane. The effects of circuit board trace inductance can result in voltage potentials greater than 1.5kV at the CDS pin. Voltage overstress of this magnitude can cause dielectric breakdown of the transceiver chip. Also, the current impulse flowing in the conductors will result in

electromagnetic coupling of transients to surrounding components on the board.

A typical Ethernet transceiver circuit with transient protection is shown in Figure 1. TVS1 and TVS2 are transient voltage suppression (TVS) diodes designed to shunt the transient current away from the protected Ethernet transceiver. The voltage across the input pins is reduced to the clamping voltage of the TVS diode, protecting the IC from damage. The TVS devices are chosen such that the working voltage is greater than the normal circuit operating voltage of 9V. Semtech's SM12 is a 300W device rated to handle the transient energy associated with ESD impulses and low level lightning induced voltages. The SM12 provides bidirectional protection in a SOT23 package, minimizing board space requirements. The devices are placed as follows: 1) BNC shield to common ground plane; 2) CDS pin to $-V_{EE}$ bus.; 3) If the HBE function is used, an additional device should be placed from HBE pin to $-V_{EE}$. A 330Ω damping resistor is shown at the input of the RXI pin to limit inrush current which may be induced into the line. Finally, good circuit board layout techniques should be used to further reduce the effects of ESD induced transients.

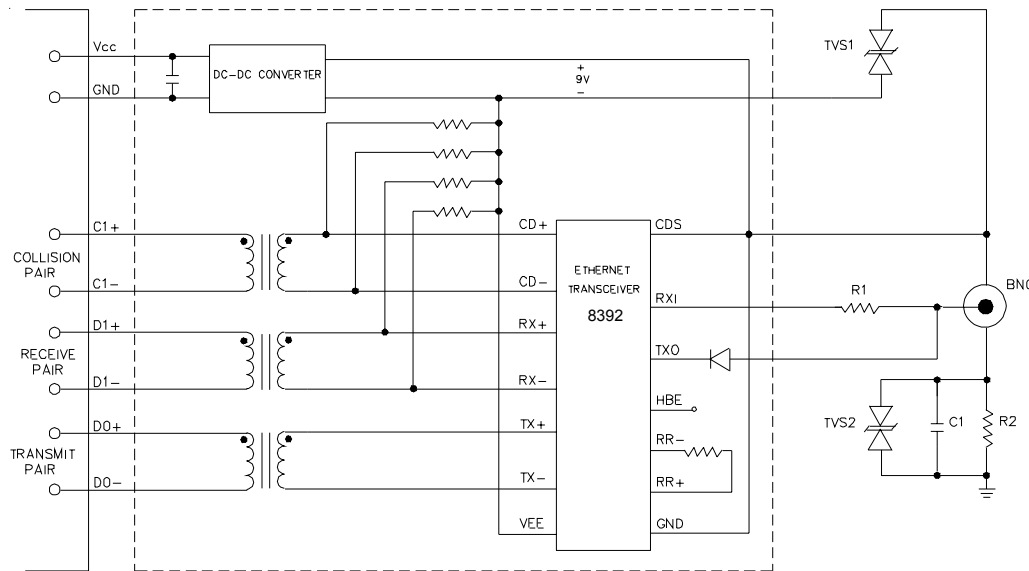

Component	Part	Description
TVS1 & TVS2	SM12	300W TVS Diode
R1	330Ω	1/2 Watt
R2	1MΩ	1/2 Watt
C1	.01μF	750V

Figure 1 - Ethernet Transceiver with ESD Protection