

### PROTECTION PRODUCTS - EMIClamp™

#### Description

The EClamp™2422N is a (C-L-C) low pass filter array with integrated TVS diodes. It is designed to suppress unwanted EMI/RFI signals and provide electrostatic discharge (ESD) protection in portable electronic equipment. This state-of-the-art device utilizes solid-state silicon-avalanche technology for superior clamping performance and DC electrical characteristics. It has been optimized for **protection of headset audio ports** in cellular phones and other portable electronics.

The device consists of two identical circuits comprised of TVS diodes for ESD protection, and a C-L-C pi-filter for EMI/RFI filtering. A typical inductor value of 2nH and a capacitor value of 100pF are used to achieve 20dB minimum attenuation from 800MHz to 2.7GHz. It has a very low series resistance of 2 Ohms, making it ideal for use on headset speaker interfaces. The TVS diodes provide effective suppression of ESD voltages in excess of  $\pm 15\text{kV}$  (air discharge) and  $\pm 8\text{kV}$  (contact discharge) per IEC 61000-4-2, level 4.

The EClamp2422N is in a 6-pin, RoHS/WEEE compliant, SLP1510N6 package. It measures 1.45 x 1.0 x 0.58mm. The leads are spaced at a pitch of 0.5mm and are finished with lead-free NiPdAu. The small package makes it ideal for use in portable electronics.

#### Circuit Diagram (Each Line)

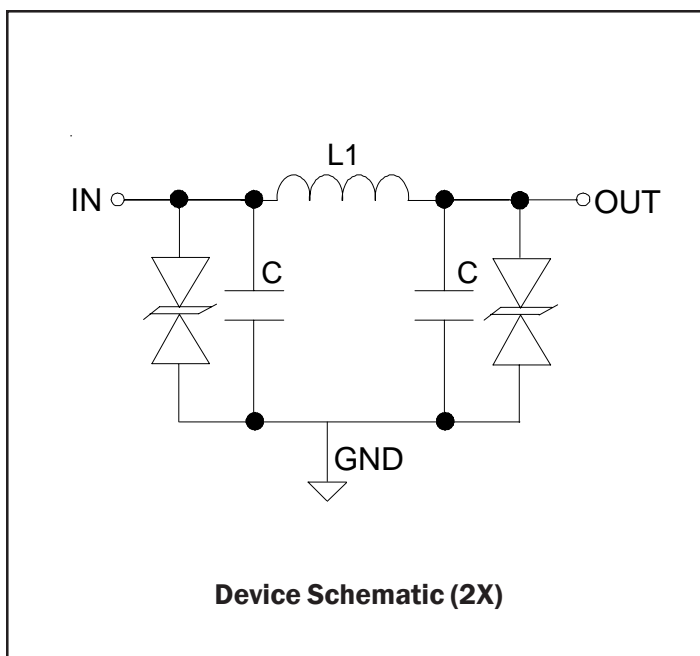

#### Features

- ◆ Bidirectional EMI/RFI filter with integrated TVS for ESD protection
- ◆ ESD protection to **IEC 61000-4-2 (ESD) Level 4,  $\pm 15\text{kV}$  (air),  $\pm 8\text{kV}$  (contact)**
- ◆ TVS working voltage: 5V
- ◆ Inductor: 2nH (Typical)
- ◆ Capacitors: 100pF (Typical at VR = 0V)
- ◆ Protection and filtering for two lines
- ◆ Solid-state technology

#### Mechanical Characteristics

- ◆ SLP1510N6 6-pin package
- ◆ RoHS/WEEE Compliant
- ◆ Nominal Dimensions: 1.45 x 1.0 x 0.58 mm
- ◆ Lead Pitch: 0.5mm
- ◆ Lead finish: NiPdAu
- ◆ Marking: Marking Code
- ◆ Packaging: Tape and Reel per EIA 481

#### Applications

- ◆ Cellular Handsets
- ◆ Speaker Ports in Portables
- ◆ Notebook Computers

#### Package Configuration

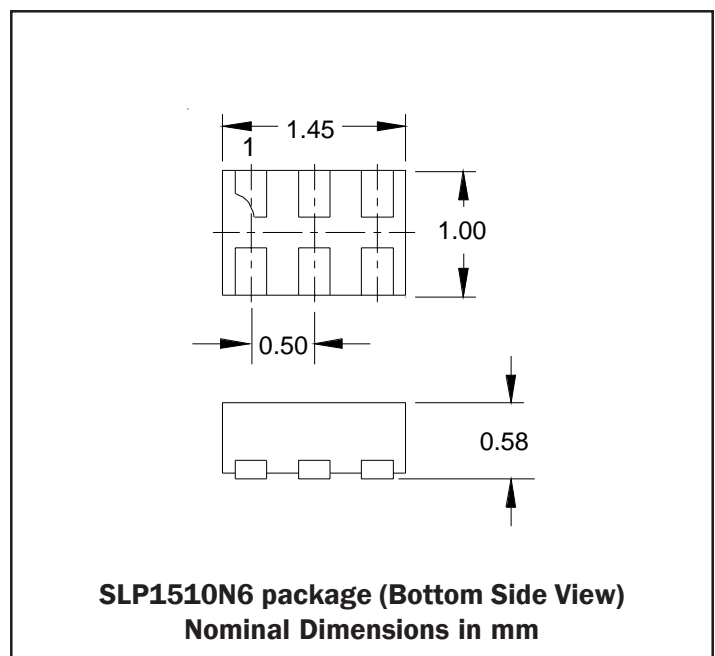

**PROTECTION PRODUCTS**
**Maximum Ratings**

Rating	Symbol	Value	Units
ESD per IEC 61000-4-2 (Air) ESD per IEC 61000-4-2 (Contact)	$V_{ESD}$	+/- 20 +/- 15	kV
Junction Temperature	$T_J$	125	°C
Operating Temperature	$T_{op}$	-40 to +85	°C
Storage Temperature	$T_{STG}$	-55 to +150	°C

**Electrical Characteristics (T=25°C)**

Parameter	Symbol	Conditions	Minimum	Typical	Maximum	Units
TVS Reverse Stand-Off Voltage	$V_{RWM}$				5	V
TVS Reverse Breakdown Voltage	$V_{BR}$	$I_t = 1mA$	6	8	10	V
TVS Reverse Leakage Current	$I_R$	$V_{RWM} = 3.3V$		0.001	0.1	μA
Equivalent Series Resistance	$R_{DC}$			1.4	2	Ohms
Inductance	L			2	3	nH
Capacitance	$C_1, C_2$	$V_R = 0V, f = 1MHz$	85	100	115	pF
Total Capacitance	$C_1 + C_2$	Input to Gnd, Each Line $V_R = 0V, f = 1MHz$		210	230	pF

## PROTECTION PRODUCTS

### Typical Characteristics

#### Typical Insertion Loss S21 (Each Line)

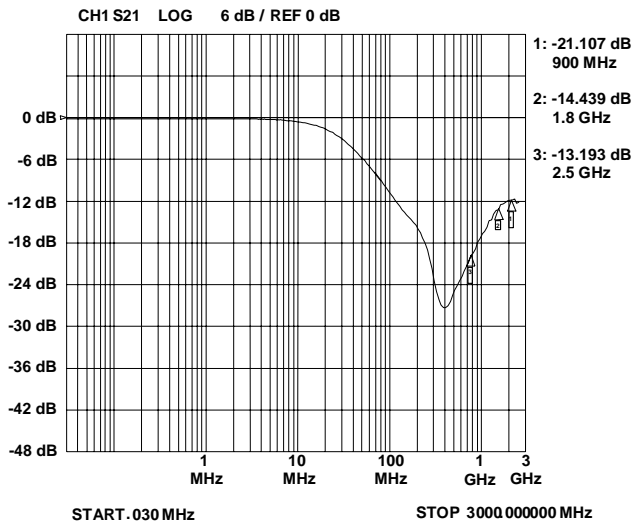

#### Analog Crosstalk (Each Line)

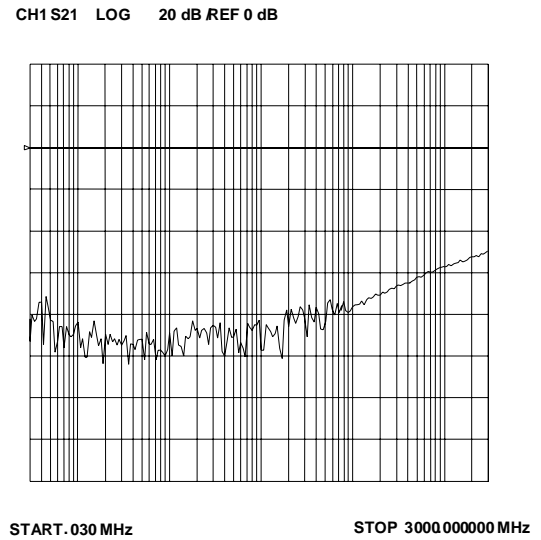

#### ESD Clamping (+8kV Contact)

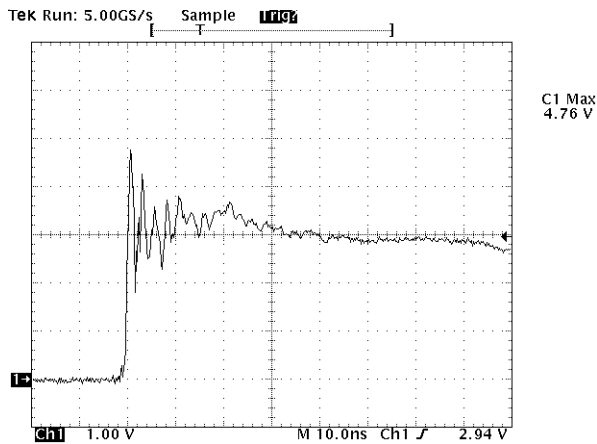

Note: Data is taken with a 10x attenuator

#### ESD Clamping (-8kV Contact)

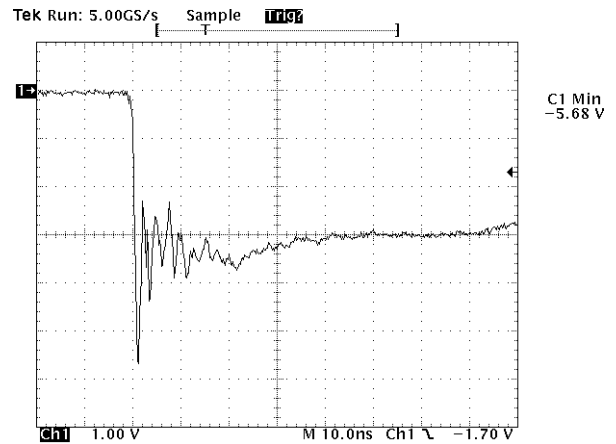

Note: Data is taken with a 10x attenuator

#### Normalized Capacitance vs. Reverse Voltage

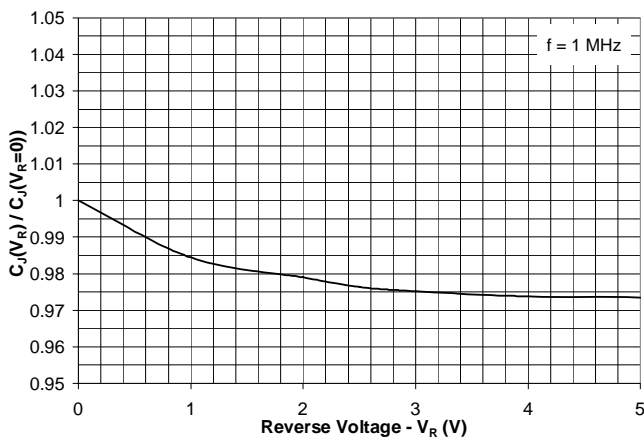

#### Clamping Voltage vs. Peak Pulse Current

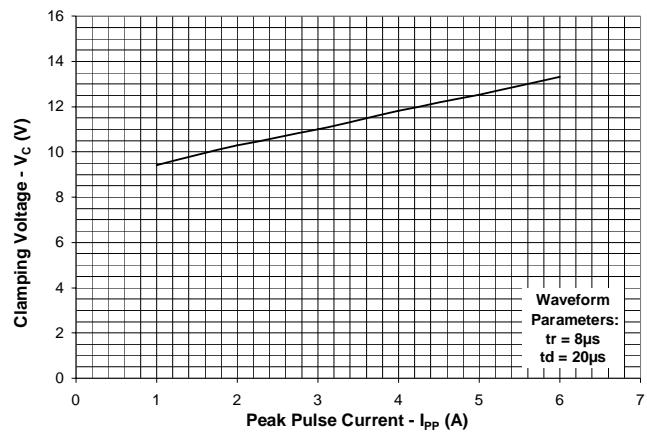

## PROTECTION PRODUCTS

### Applications Information

#### Device Connection

The EClamp2422N provides EMI filtering and ESD protection in a small SLP1510N6 package for speaker port applications. The equivalent circuit diagram is shown in Figure 1. The layout of the device is designed such that the data lines can be routed through the device. The first line pair enters at pin 1 and exits at pin 6. The second line pair enters at pin 2 and exits at pin 5. The device is symmetrical so the above connections may be reversed. Ground connection is made at pins 3 and 4.

#### Circuit Board Layout Recommendations for Suppression of ESD.

Good circuit board layout is critical for the suppression of ESD induced transients. The following guidelines are recommended:

- Place the TVS near the input terminals or connectors to restrict transient coupling.
- Minimize the path length between the TVS and the protected line.
- Minimize all conductive loops including power and ground loops.
- The ESD transient return path to ground should be kept as short as possible.
- Never run critical signals near board edges.
- Use ground planes whenever possible.

Figure 1 -Circuit Diagram (Each Line)

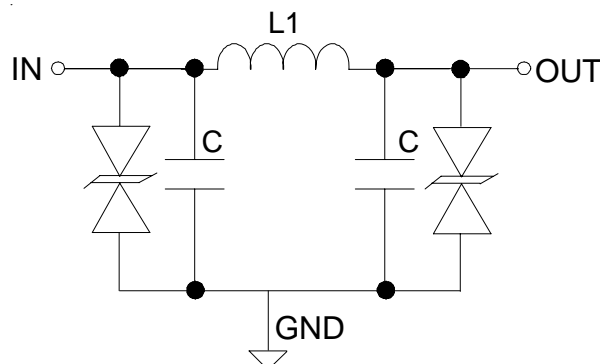
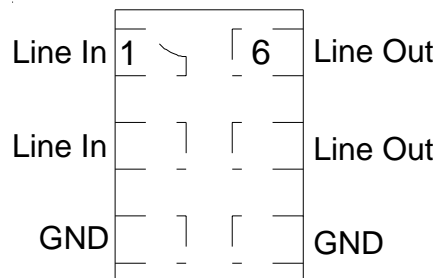
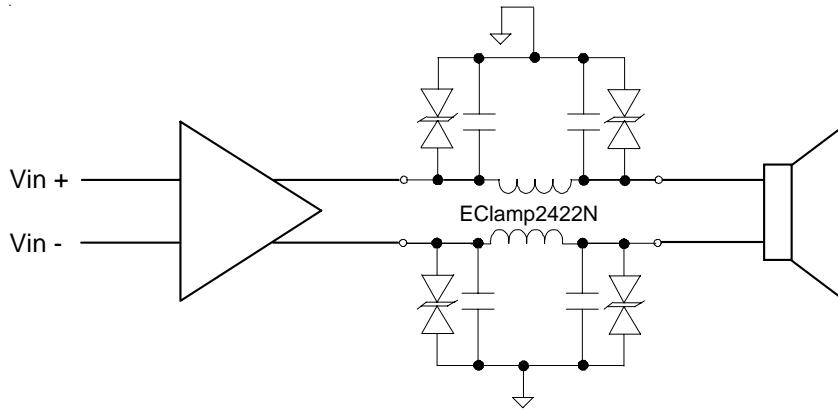

Figure 2 - Pin Identification and Configuration (Top Side View)



Pin	Identification
1, 2	Input Lines from Speaker
5, 6	Output Lines to Audio Ckt
3, 4	Ground



**Differential Mode Protection with Speaker Output**

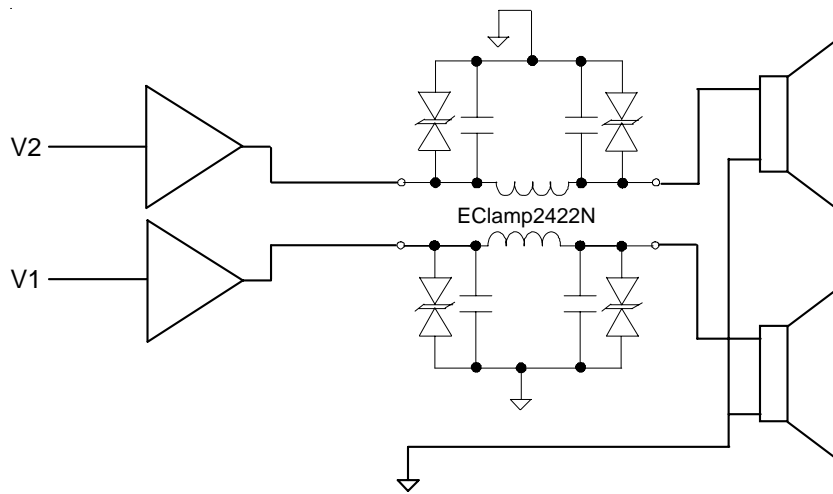

**Protection of Two Single-Ended Mode Speakers**

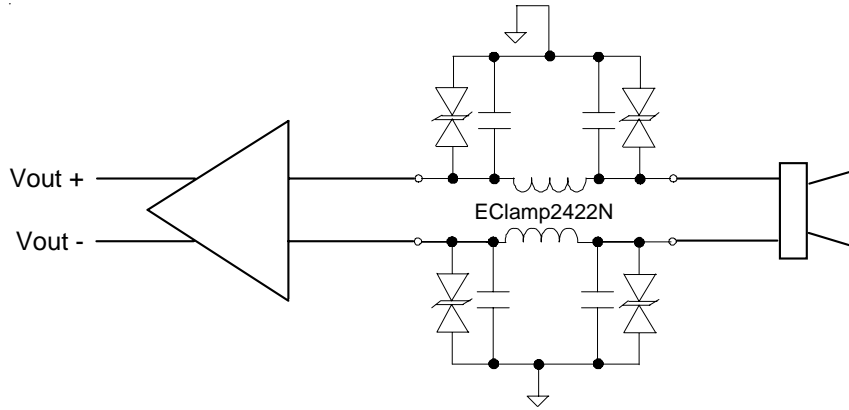

**Differential Mode Protection with Microphone Input**

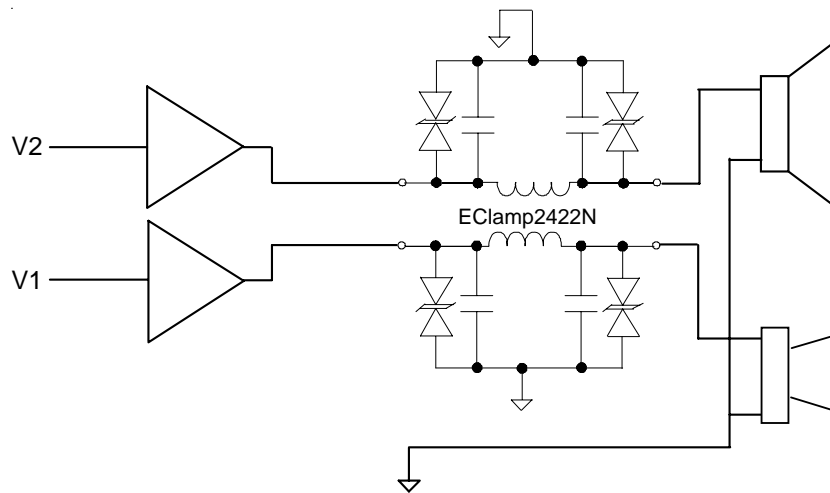

**Protection of Single-Ended Mode Microphone and Speaker Output**

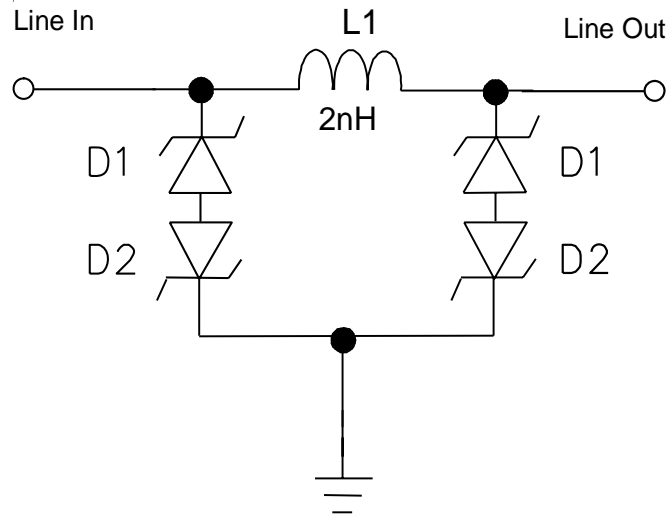
**EClamp2422N Spice Model**
**Table 1 - EClamp2422N Spice Parameters**

Parameter	Unit	D1 (TVS)	D2 (TVS)
IS	Amp	4.09E-15	4.09E-15
BV	Volt	7.7	7.7
VJ	Volt	0.7	0.7
RS	Ohm	0.416	0.416
IBV	Amp	1E-3	1E-3
CJO	Farad	210E-12	210E-12
TT	sec	2.541E-9	2.541E-9
M	--	0.01	0.01
N	--	1.1	1.1
EG	eV	1.11	1.11

## PROTECTION PRODUCTS

### Outline Drawing - SLP1510N6

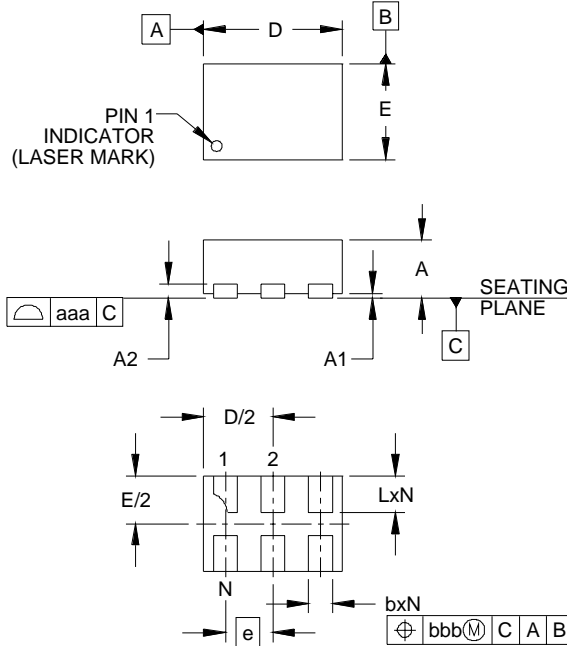

DIM	INCHES		MILLIMETERS			
	MIN	NOM	MAX	MIN	NOM	MAX
A	.020	.023	.026	0.50	0.58	0.65
A1	0.00	.001	.002	0.00	0.03	0.05
A2		(.005)			(0.13)	
b	.008	.010	.012	0.20	0.25	0.30
D	.053	.057	.061	1.35	1.45	1.55
E	.035	.039	.043	0.90	1.00	1.10
e		.020 BSC			0.50 BSC	
L	.012	.015	.017	0.30	0.38	0.425
N		6			6	
aaa		.003			0.08	
bbb		.004			0.10	

**NOTES:**

1. CONTROLLING DIMENSIONS ARE IN MILLIMETERS (ANGLES IN DEGREES)

### Land Pattern - SLP1510N6

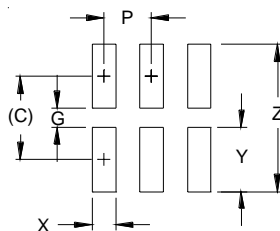

DIM	DIMENSIONS	
	INCHES	MILLIMETERS
C	(.034)	(0.875)
G	.008	0.20
P	.020	0.50
X	.010	0.25
Y	.027	0.675
Z	.061	1.55

**NOTES:**

1. THIS LAND PATTERN IS FOR REFERENCE PURPOSES ONLY. CONSULT YOUR MANUFACTURING GROUP TO ENSURE YOUR COMPANY'S MANUFACTURING GUIDELINES ARE MET.

## PROTECTION PRODUCTS

### Marking

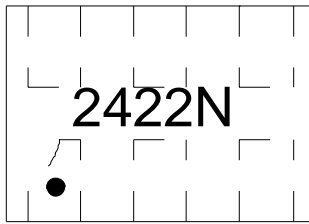

### Ordering Information

Part Number	Qty per Reel	Reel Size
EClamp2422N.TCT	3000	7 Inch

EMIClamp and EClamp are marks of Semtech Corporation

### Tape and Reel Specification

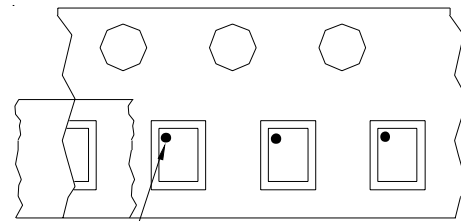
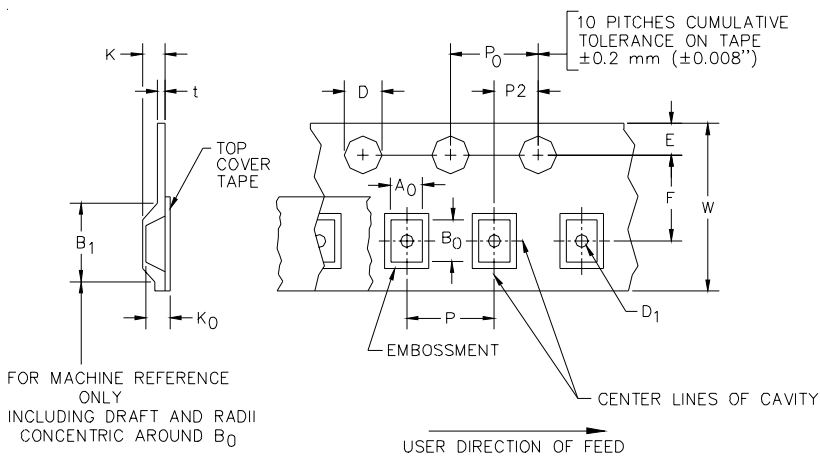

Pin 1 Location

User Direction of feed

### Device Orientation in Tape

A0	B0	K0
1.24±0.05mm	1.70±0.05mm	0.76±0.05mm

Tape Width	B, (Max)	D	D1	E	F	K (MAX)	P	P0	P2	T(MAX)	W
8 mm	4.2 mm (.165)	1.5 + 0.1 mm - 0.0 mm (0.59 +.005 - .000)	0.8 mm ±0.05 (.031)	1.750±.10 mm (.069±.004)	3.5±0.05 mm (.138±.002)	2.4 mm (.094)	4.0±0.1 mm (.157±.004)	4.0±0.1 mm (.157±.004)	2.0±0.05mm (.079±.002)	0.4 mm (.016)	8.0 mm + 0.3 mm - 0.1 mm (.312±.012)

### Contact Information for Semtech International AG

**Taiwan Branch**  
Tel: 886-2-2748-3380  
Fax: 886-2-2748-3390

**Korea Branch**  
Tel: 82-2-527-4377  
Fax: 82-2-527-4376

**Shanghai Office**  
Tel: 86-21-6391-0830  
Fax: 86-21-6391-0831

Semtech International AG is a wholly-owned subsidiary of Semtech Corporation, which has its headquarters in the U.S.A.

**Semtech Switzerland GmbH  
Japan Branch**  
Tel: 81-3-6408-0950  
Fax: 81-3-6408-0951

**Semtech Limited (U.K.)**  
Tel: 44-1794-527-600  
Fax: 44-1794-527-601

**Semtech France SARL**  
Tel: 33-(0)169-28-22-00  
Fax: 33-(0)169-28-12-98

**Semtech Germany GmbH**  
Tel: 49-(0)8161-140-123  
Fax: 49-(0)8161-140-124