

**PROTECTION PRODUCTS**

**DVI Protection**

The industry's demand for high-resolution flat panels requires more complex digital and analog solutions in a dense area. The small geometry's of the digital-visual interface (DVI) graphic chip makes it more susceptible to electrostatic discharges (ESD) and cable discharge events (CDE). The industry ESD standard is IEC61000-4-2. It requires the system to withstand 8kV contact and 15kV air ESD.

Transient protection of a DVI port can be challenging. Digital-visual interfaces can often transmit and receive at a rate equal to or above 1Gbps. The high-speed data transmission requires the protection device to have low capacitance to maintain signal integrity and low clamping voltage to reduce stress on the protected IC. The SRV05-4 TVS array is specifically designed for this application.

The SRV05-4 has a low capacitance of 3pF from any I/O pin (pin 1,3,4 or 6) to ground (pin 2) or 1.5pF from any I/O pin to I/O pin. The insertion loss characteristic of the SRV05-4 is shown in Figure 2. The graph shows that the device has a low insertion loss of 0.4dB at 1GHz (I/O to ground). The SRV05-4 is also designed to withstand the energy of a 15kV air and 8kV contact ESD event. Figure 3 shows that the SRV05-4 clamps an 8kV contact ESD surge to less than 20V. The SRV05-4 will also protect the DVI graphic chip against CDE.

Figure 4 shows how to design the SRV05-4 into the DVI circuit on the flat panel display and in a PC graphic card. The SRV05-4 is configured to provide common mode and differential mode protection. The internal TVS of the SRV05-4 acts as a 5 volt reference. The power pin of the DVI circuit does not come out through the connector and is not subjected to external ESD pulse; therefore, pin 5 should be left unconnected. Connecting pin 5 to Vcc of the DVI circuit may result in damage to the chip from ESD current.

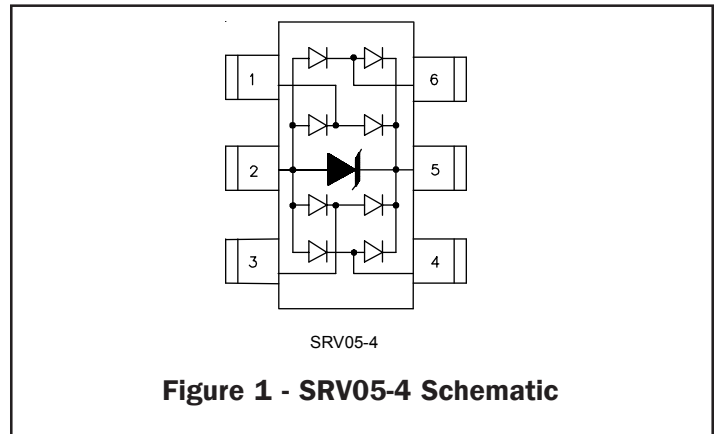

**Figure 1 - SRV05-4 Schematic**

