

# Product Brief



SEMTECH PROTECTION PRODUCTS

## ESD/CDE Protection

For High Definition Multimedia Interface (HDMI)



### Breakthrough protection device for HDMI 1.3 with ultra low capacitance of 0.3pF

High Definition Multimedia Interface (HDMI) is an uncompressed, all-digital audio/video interface that provides a high speed link between audio/video source and sink devices. Semtech products provide robust protection while preserving signal integrity in high-speed video and data interfaces such as Set Top Boxes (STB), DVD players, PCs, video cameras, gaming stations, and digital televisions.

#### Requirements:

- Pass Compliance Test Specification (CTS) on sink and source sides: 100 +/- 15% trace impedance
- Pass Eye Pattern Test using HDMI Eye Mask

#### Applications and Features:

- Ultra-low capacitance: 0.3pF typical (line-to-line)
- Industry's lowest clamping voltage
- Small package solution, including flow through leadless package (SLP) to maintain signal integrity
- Solid-state silicon-avalanche technology does not degrade after repeated strikes
- RoHS/WEEE Compliant
- Meets industry immunity standard: IEC 61000-4-2 (ESD) +/-15kV (air), +/-8kV (contact)

With the increase in data speed, maintaining signal integrity is crucial to meet the HDMI eye pattern and TDR requirement. This is not a trivial task, as the differential impedance can be affected by even a small amount of capacitance or inductance. Externally accessible HDMI ports are increasingly more susceptible to transient threats as well. Threats can come from a user's direct touch or from hot plugging a charged cable.

Internal on-chip ESD protection does not provide sufficient protection to keep the sensitive HDMI chip from becoming damaged; thus, most consumer electronics manufacturers require HDMI ports to meet the IEC 61000-4-2 ESD standard. To protect against the over-voltage stress induced by users and ESD testing, external protection is required. With this added concern, HDMI designers need to meet the ESD immunity requirement of IEC 61000-4-2 while maintaining signal integrity and impedance requirements per the HDMI CTS.

The chosen protection device must exhibit very low capacitance while keeping the ESD clamping voltage at a minimum to maintain the quality and reliability of the protected IC. This will ensure that the HDMI chip will not experience catastrophic or latent failure during a transient threat.

# Product Brief

## RClamp0524P – Breakthrough Protection Device for HDMI 1.3

Semtech's HDMI device, RClamp0524P, is a 5V, 10-pin device that offers a maximum differential capacitance value of 0.3pF. The device can be used directly on 2 pairs of 100 Ohm differential impedance signal lines regardless of the stack up or number of layers. Designers can incorporate the 100 Ohm differential impedance per their board parameters, and Semtech RClamp0524P's ultra-low capacitance will have very little affect to the already calculated and controlled impedance. To further facilitate the high speed design, the RClamp0524P is housed in a small leadless package with 0.5mm pitch, flow-through layout. The package design helps reduce discontinuities and increase common noise rejection through tight-pitch coupling.

Figure 1 shows an example of high speed differential trace routing with Semtech RClamp0524P.

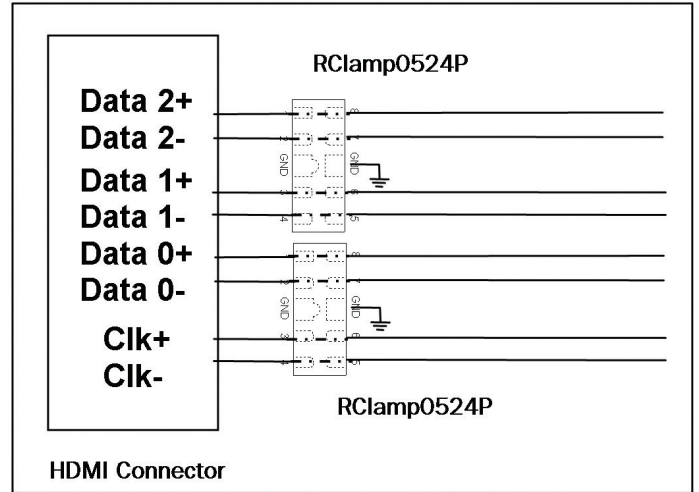

Figure 1

Figure 2 and Figure 3 respectively shows the passing eye pattern result using Semtech's RClamp0524P.

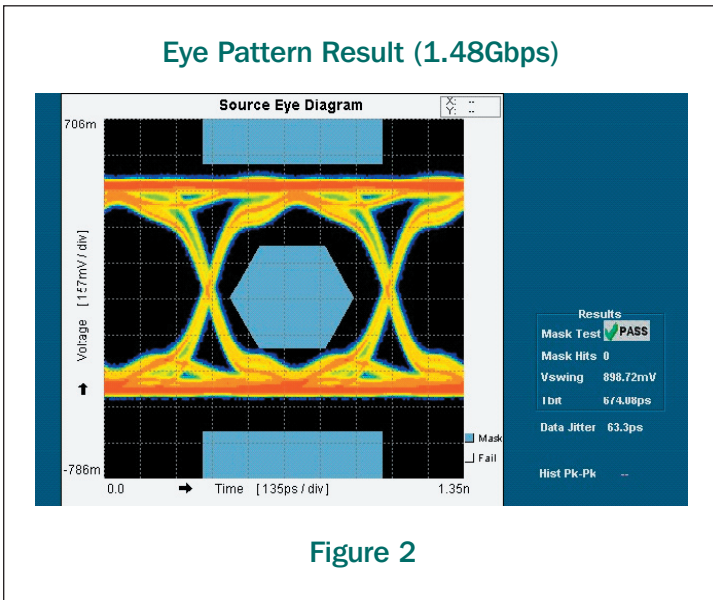

Figure 2

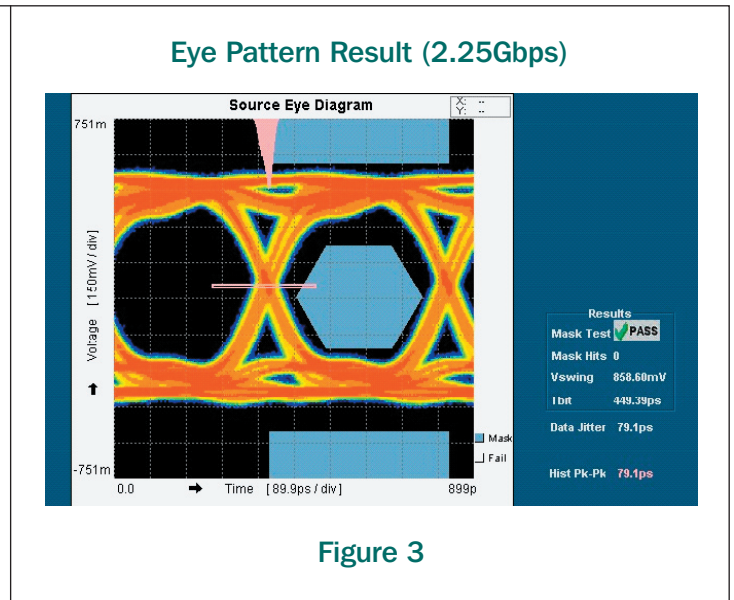

Figure 3

Visit our website to locate most current product specifications, datasheets and contact information for your local Semtech Field Applications Engineer.