AN8000.12

Application Note

Wireless Compass

Table of Contents

1	INTRODUCTION	3
2	GENERAL DESCRIPTION	3
2.1	BLOCK DESCRIPTION	3
2.2	FUNCTIONAL DESCRIPTION	4
2.3	COMPONENTS DESCRIPTION	4
2.3.1	<i>Compass Sensor.....</i>	<i>4</i>
2.3.2	<i>XE8805/05A microcontroller</i>	<i>4</i>
2.3.3	<i>XE1209 Transceiver (30 – 70 kHz) for short-range apps (1 to 3 meters).....</i>	<i>4</i>
2.3.4	<i>XE1201A Transceiver (300 - 500 MHz) for long range apps (200 to 300 meters).....</i>	<i>4</i>
3	SENSOR INTERFACE.....	5
3.1	MEASURE PRINCIPLE.....	5
3.1.1	<i>HMC1052 characteristics.....</i>	<i>5</i>
3.1.2	<i>XE8805/05A ZoomingADC™ characteristics.....</i>	<i>7</i>
3.1.3	<i>ZoomingADC™ configuration example.....</i>	<i>7</i>
3.1.4	<i>Hardware Interface.....</i>	<i>9</i>
3.1.5	<i>Measurement Flowchart</i>	<i>9</i>
4	RF TRANSCEIVER INTERFACE	13
4.1	PROTOCOL DESCRIPTION	13
4.2	HARDWARE INTERFACE	14
4.2.1	<i>XE1209 - XE8805/05A interface.....</i>	<i>14</i>
4.2.2	<i>XE1201A - XE8805/05A interface.....</i>	<i>15</i>
4.3	RF LINK FLOWCHART.....	17
5	SYSTEM PERFORMANCES	20
6	MOBILE SYSTEM SCHEMATICS.....	21
7	BOARD DESCRIPTION.....	22

1 Introduction

The aim of this application note is to explain the different steps to build a wireless compass based on XE8805/05A capabilities. This application note demonstrates XE8805/05A performances as both sensing machine and RF communication driver. To implement the compass function, we use a HMC1052 magnetic sensor. XE1209 (LW) or XE1201A (UHF) radio transceivers are used to handle RF communication.

2 General Description

2.1 Block Description

Figure 1 shows a wireless compass sensing machine. This system is composed of two different parts:

- The first part, including compass sensor, which is mobile
- The second part, which is connected to a base station (PC)

The mobile system includes a HMC1052 compass sensor, a transceiver (XE1201A or XE1209) and a XE8805/05A microcontroller.

The base system includes a transceiver (XE1201A or XE1209), a XE8805/05A microcontroller and a PC.

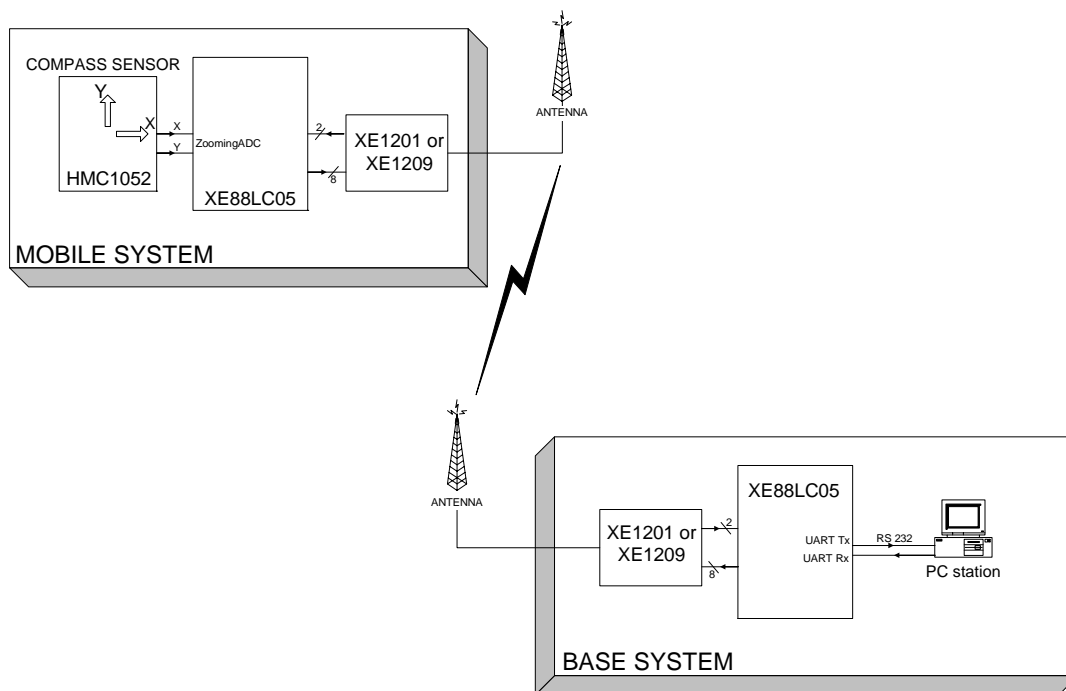

Figure 1 : Global Description

2.2 Functional Description

The mobile system is in reception mode and waits for a command message from the base system. This command can be “measure” or “calibrate”. If it is “measure”, the mobile system performs an acquisition, calculates heading and finally sends the measure to the base station. If it is “calibrate”, it performs a calibration of the compass sensor in order to eliminate its offset.

On the other hand, the base system is waiting for an UART message. This message can be “measure request” or “calibration request”. If it is “measure request”, the base system sends the command “measure” to the mobile system and waits for the measure. When it receives the measure, it is sent to the PC using UART connection. Then the position appears on the Com Port interface.

2.3 Components description

2.3.1 Compass Sensor

HMC1052 is a high performance two-axis magnetoresistive sensor on a single chip. Advantages of this design include perfectly orthogonal two-axis sensing, ultra small size and low power.

HMC1052 sensitivity is $1mV/V_{supply}/Oersted$ (1Oersted=1Gauss=1 μ Tesla). As Earth’s magnetic field is about 0.5 Gauss, the HMC1052 sensor is very efficient in compassing applications. Sensor principle is the following. There are two resistive Wheatstone bridges formed by a magnetoresistive metal film. When a power supply is connected to the bridge, the sensor converts any ambient or applied magnetic field in the sensitive direction to a voltage output.

For more information about this product, consult <http://www.magneticsensors.com> web site.

2.3.2 XE8805/05A microcontroller

The XE8805/05A is an ultra low-power microcontroller unit associated with a versatile analog-to-digital converter including programmable offset and gain pre-amplifier. This acquisition chain named ZoomingADC™ also includes an analog multiplexer (AMUX) allowing selection of four differential input channels.

As the XE8805/05A has several sources of interrupts and events, it can directly read the XE1201A or XE1209 data output and synchronized clock.

2.3.3 XE1209 Transceiver (30 – 70 kHz) for short-range apps (1 to 3 meters)

The XE1209 is a CMOS Ultra Low-Power single chip transceiver for short-range low frequency RF data communications system. It uses 2-level Continuous Phase FSK modulation. The receiver section includes the preamplifier, the down-converter, the channel filters, the demodulator and the bit synchronizer, which delivers synchronized data at the output. The transmitter section is composed of a Direct Digital Synthesizer, and the power amplifier generating a square-wave output current. The XE1209 has a peak detector to detect the presence of a signal at the carrier frequency. The local clock is based on a 32 kHz crystal oscillator and a PLL to generate the required output frequency. The XE1209 has a simple interface with an external microcontroller.

2.3.4 XE1201A Transceiver (300 - 500 MHz) for long range apps (200 to 300 meters)

The XE1201A is a half-duplex FSK transceiver for operation in the 433 MHz ISM band (optimized) and in the 300-500 MHz band. The modulation used is the Continuous Phase, 2 level Frequency Shift Keying (CPFSK). The direct conversion (zero-IF) receiver architecture enables on-chip channel filtering.

The XE1201A includes a bit synchronizer so that glitch free data with synchronized clock can directly be read by a low cost / low complexity microcontroller. The transmitted power level can also be controlled via the bus.

For more information on XE8000 microcontroller series and XE1200 RF transceiver series, please consult the Semtech website <http://www.semtech.com>.

3 Sensor Interface

3.1 Measure Principle

3.1.1 HMC1052 characteristics

HMC1052 is a two-axis linear magnetic field sensor. Each sensor is a resistive Wheatstone bridge formed by a magnetoresistive metal film. This device contains two magnetic field sensors with sensitive directions perpendicular to each other. Sensor A and Sensor B coexist on a single silicon chip with nearly perfect orthogonality and matching characteristics.

Figure below shows internal circuit diagram of the HMC1052 sensor, with its two Wheatstone bridges.

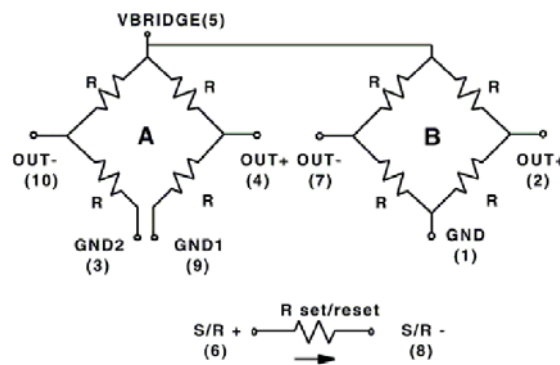

Figure 2 : HMC1052 internal circuit

As the sensor has two axis, measuring differential output voltage on each one gives Earth magnetic field X and Y components. Using mathematical expression **Arctan (Y / X)** allows to calculate the heading angle of the compass. Depending on the sign of X and Y components, heading position can be calculated as below:

IF (|Y| > |X|)

For (Y < 0) **Heading** = - (arcTan $\frac{X}{Y}$ - 90°)

For (Y > 0) **Heading** = 180° - (arcTan $\frac{X}{Y}$ - 90°)

IF (|X| > |Y|)

For (X > 0, Y < 0) **Heading** = 360° + arcTan $\frac{Y}{X}$

For (X > 0, Y > 0) **Heading** = arcTan $\frac{Y}{X}$

For (X < 0) **Heading** = 180° + arcTan $\frac{Y}{X}$

IF (|X| = |Y|)

For (X > 0, Y > 0) **Heading** = 45°

For (X > 0, Y < 0) **Heading** = 315°

For (X < 0, Y > 0) **Heading** = 135°

For (X < 0, Y < 0) **Heading** = 225°

Sensor sensitivity is approximately 1mV / V /Gauss, so the sensor transfer function is the following for Vbridge = 3 Volts.

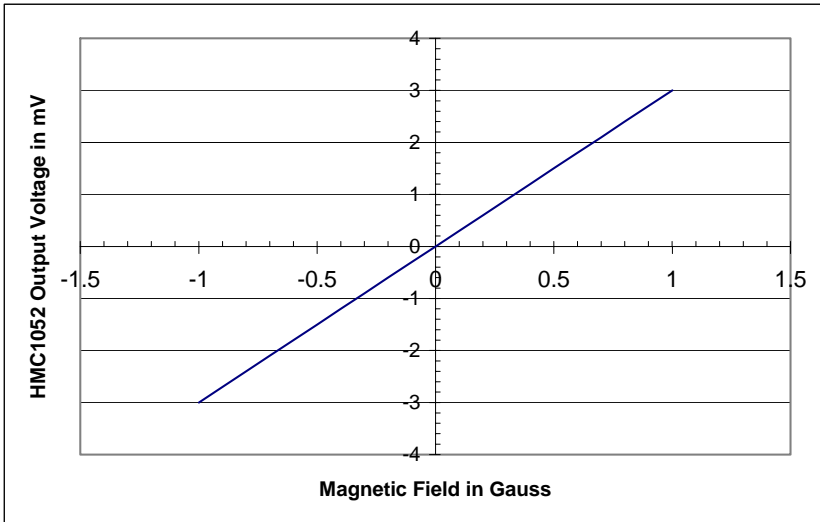

Figure 3 : HMC1052 Transfer Function

This transfer function does not include bridge offset that could be from -2.5 mV / V to 2.5 mV / V . Because the Earth's magnetic Field maximal value is 0.5 Gauss, it is possible to zoom on this chart.

Figure 4 below shows sensor output characteristic without offset, and both positive and negative maximum offset.

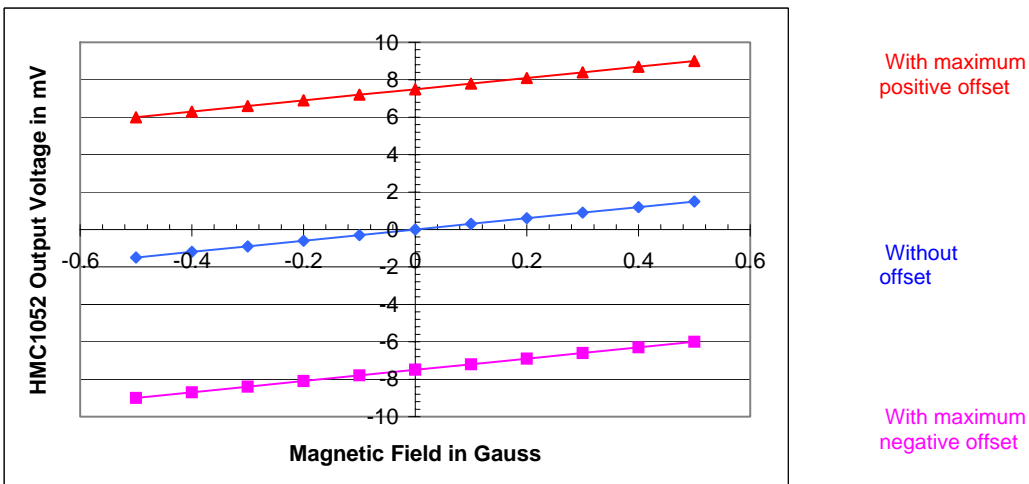

Figure 4 : Zoom on HMC1052 Transfer Function with bridge offset

For more details on Honeywell HMC1052 magnetic sensor, consult:

<http://www.magneticsensors.com/datasheets/hmc1051-1052.pdf> .

3.1.2 XE8805/05A ZoomingADC™ characteristics

XE8805/05A ZoomingADC™ is appropriate for that kind of measure thanks to its programmable gain amplifier with offset compensation (PGAs). It also allows the measure of the two axis with its efficient analog multiplexer.

See below Figure 5 that shows XE8805/05A ZoomingADC™ block diagram.

ZoomingADC

The fully differential acquisition chain is formed of a programmable gain (0.5 - 1000) and offset amplifier and a programmable speed and resolution ADC (example: 12 bits at 4 kHz, 16 bits at 1 kHz). It can handle inputs with very low full scale signal and large offsets.

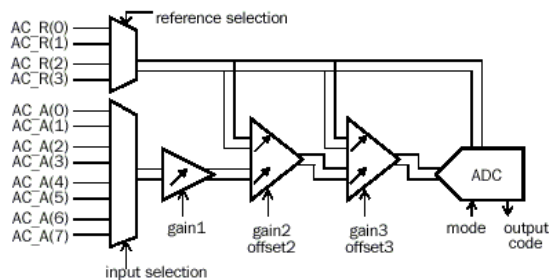

Acquisition channel block diagram

Input selection is made from 1 of 4 differential pair or 1 of seven single signal versus AC_A(0). Reference is chosen from the 2 differential references.

The gain of each amplifier is programmed individually. Each amplifier is powered on and off on command to minimize the total current requirement. All blocks can be set to low frequency operation and lower their

Figure 5 : ZoomingADC™ block diagram

In our case, the two axis of the sensor are respectively connected to the first (AC_A0–AC_A1) and second (AC_A2–AC_A3) input channel of ZoomingADC™ and all PGAs are enabled. The AD converter is used to convert the differential input signal into a 16 bit 2's complement output format.

For more details on ZoomingADC™ performances, consult AN8000.05 on the Semtech website.

3.1.3 ZoomingADC™ configuration example

$V_{supply} = \text{ZoomingADC}^{\text{TM}} \text{ reference } (V_{ref}) = 3 \text{ V}$

How does one calculate the necessary gain to cover ADC full scale?

First, one has to measure the maximum (in absolute value) output voltage of the sensor he is using because each sensor has its own offset.

$$\text{Gain} = \frac{V_{ref}/2}{|V_{out}(\text{max})|}$$

How does one calculate the necessary offset compensation for each axis?

A software routine calculates this offset compensation. It is called **calibration ()**.

During this routine execution, one has to rotate the sensor in all direction to be sure that the acquisition chain measures X & Y components extreme value (Xmax, Xmin, Ymax, and Ymin).

At the end of the calibration routine, the program calculates offset compensation the way below:

$$X_{\text{offset}} = \frac{X_{\text{max}}}{2} + \frac{X_{\text{min}}}{2}$$

$$Y_{\text{offset}} = \frac{Y_{\text{max}}}{2} + \frac{Y_{\text{min}}}{2}$$

These offsets are subtracted from each measure:

$$X = X_{\text{measure}} - X_{\text{offset}}$$

$$Y = Y_{\text{measure}} - Y_{\text{offset}}$$

When all these parameters are defined, ZoomingADC™ output characteristic is the one on Figure 6 below:

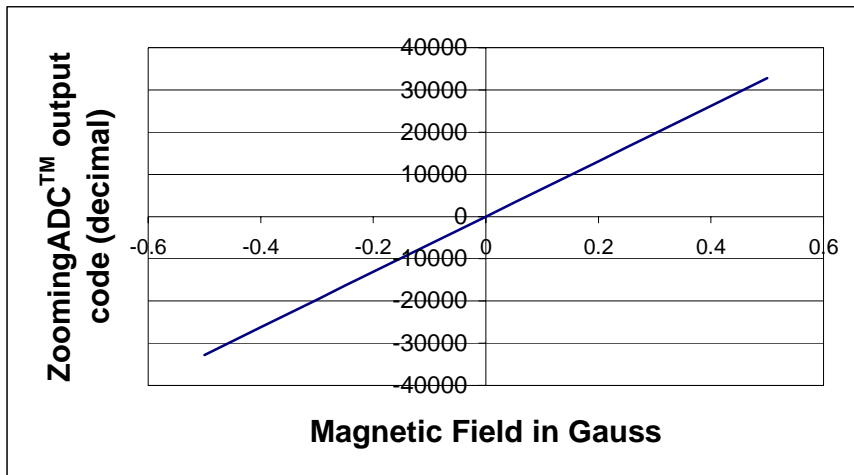

Figure 6 : ZoomingADC™ block diagram

3.1.4 Hardware Interface

Interfacing HMC1052 and XE8805/05A is quite simple. Each differential output voltage of the sensor is connected to one ZoomingADC™ input channel.

For lower power consumption, sensor voltage supply is connected to XE8805/05A pin PB [2] and PB [3] as ZoomingADC™ voltage reference is.

To perform a 0.5 A set pulse on the sensor, a RC circuit with a push button are used.

Figure 7 shows HMC1052-XE8805/05A hardware interface.

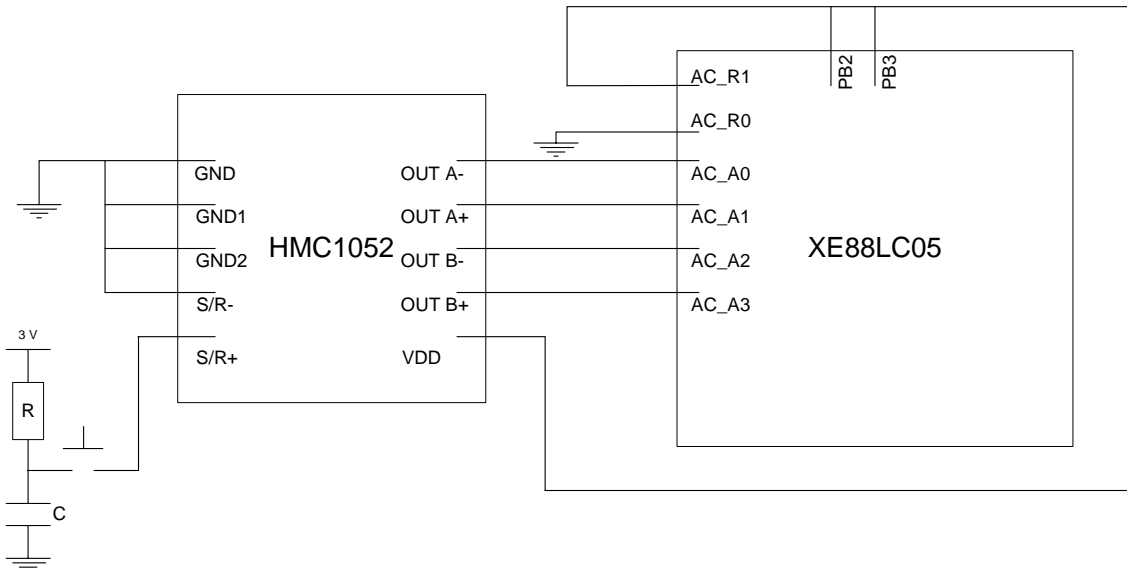

Figure 7 : HMC1052-XE8805/05A interface

3.1.5 Measurement Flowchart

First, you need to initialize ZoomingADC™ configuration registers with the appropriate value. You can see below the configuration register map on Figure 8.

Address	Reg name	D7 D6 D5 D4 D3 D2 D1 D0					
0x060	RegAcOut0	OUT(7:0)					
0x061	RegAcOut1	OUT(15:8)					
0x062	RegAcCfg0	START	NELCONV(1:0)	OSR(2:0)		CONT	TEST=0
	Default values:	0	01	010		0	0
0x063	RegAcCfg1	IB_AMP_ADC(1:0)		IB_AMP_PGA(1:0)		ENABLE(3:0)	
	Default values:	11		11		0001	
0x064	RegAcCfg2	FIN(1:0)		PGA2_GAIN(1:0)		PGA2_OFFSET(3:0)	
	Default values:	00		00		0000	
0x065	RegAcCfg3	PGA1_GA	PGA3_GAIN(6:0)				
	Default values:	0	0001100				
0x066	RegAcCfg4	PGA3_OFFSET(6:0)					
	Default values:	0000000					
0x067	RegAcCfg5	BUSY	DEF	AMUX(4:0)			VMUX
	Default values:	0	0	00000			0

Figure 8 : ZoomingADC™ register map

X and Y components cannot be measured simultaneously. You need to use AMUX (4:0) to select the appropriate input channel. In our case, AMUX = 0 (select Vin1 = AC_A0 – AC_A1) to measure X component and AMUX = 1 (select Vin2 = AC_A2 – AC_A3) to measure Y component.

The last step is the heading calculation.

You can see in the table below (Figure 9) the aim of each function used in measurement application.

<i>Function name</i>	<i>Function purpose</i>	<i>Source file</i>
Init_ZoomingADC ()	initialize acquisition chain configuration registers	measure.c
Meas_X ()	AMUX configure on Channel1 (Vin1) and measure X	measure.c
Meas_Y ()	AMUX configure on Channel2 (Vin2) and measure Y	measure.c
Calibration ()	Measure X & Y 300 times to find each axis offset	measure.c
Heading ()	Calculate heading position of the compass	measure.c
meas_calc_heading ()	Measure X & Y component and calculate heading	measure.c

Figure 9 : Measure Functions.

Figure 10 shows measurement flowchart that explains different steps of heading calculation.

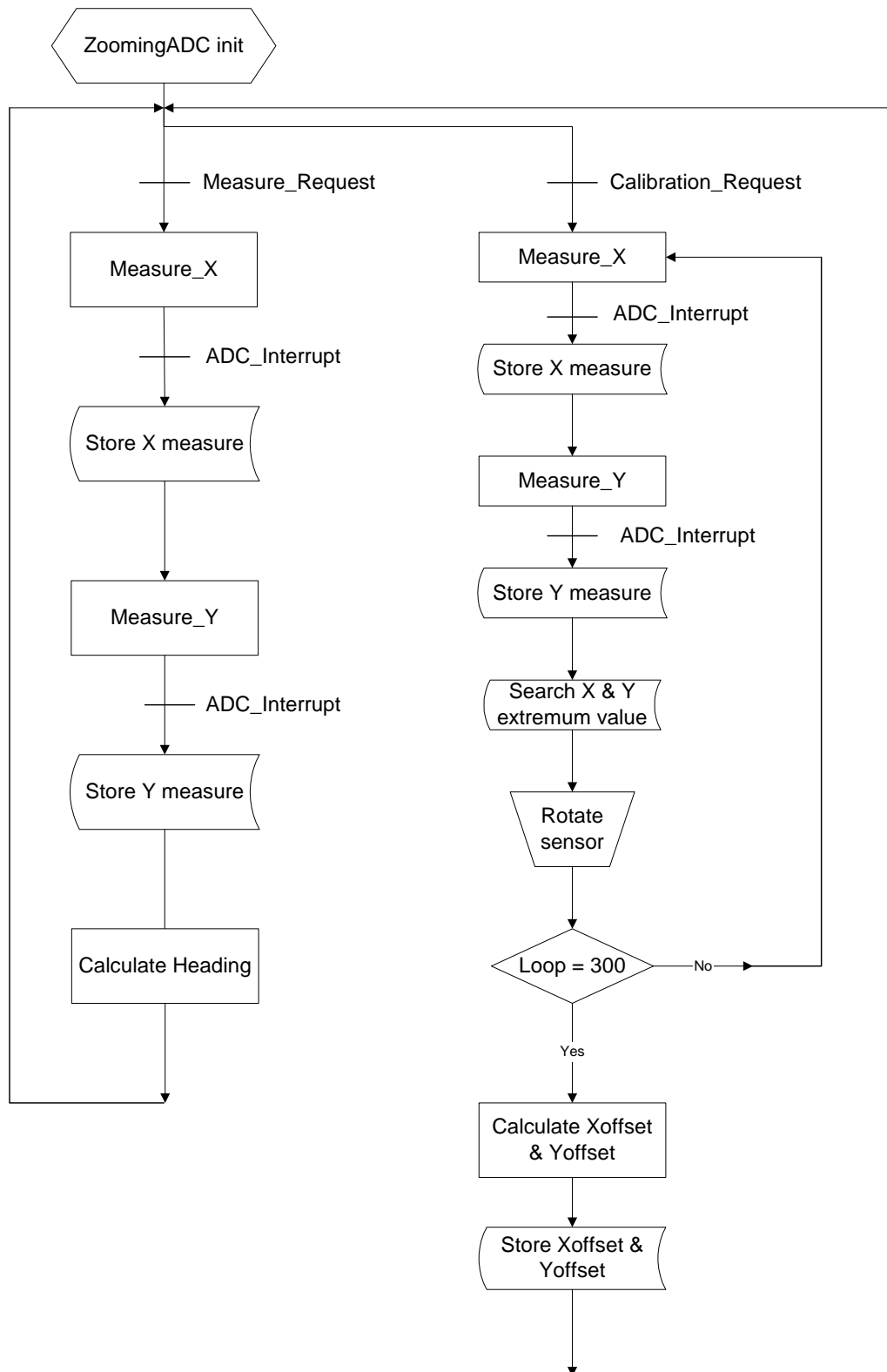

Figure 10 : Measurement Flowchart

4 RF Transceiver Interface

To achieve an RF link, use of Semtech's RF transceivers is quite easy. Their programming via a 3-wire bus facilitates interface with microcontrollers. In our case, XE1209 (30–70 kHz band) and XE1201A (300–500 MHz band) are used to handle the RF link, depending on the frequency and on the range one wants to use for RF communication.

4.1 Protocol Description

This description handles both XE1209 and XE1201A RF transceivers. Only the programming changes between these transceivers because XE1209 has only one programming register whereas XE1201A has three.

Figure 11 below describes RF frame contents.

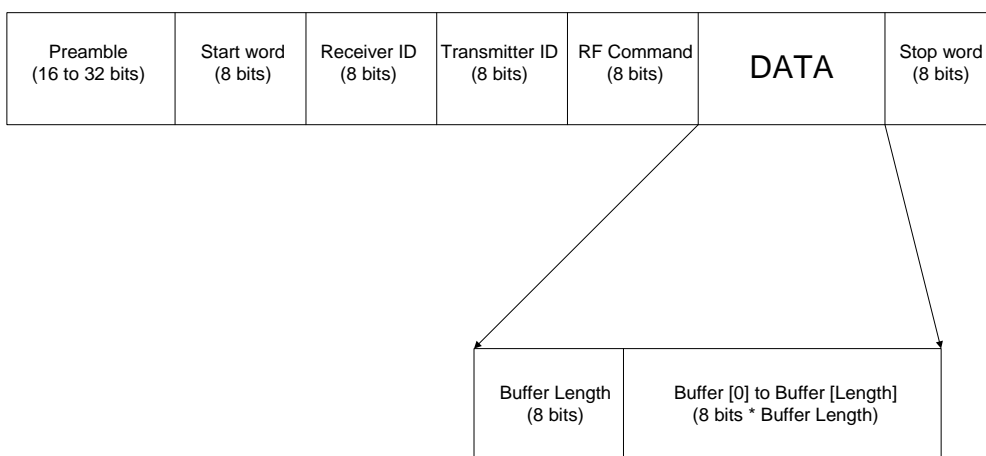

Figure 11 : RF Frame contents

Preamble is a sequence of "0" and "1" used to synchronize data and clock at transceiver output.

Start word defines the beginning of RF transmission.

Receiver ID and **Transmitter ID** define recipient and owner identity. In our case, they are not very useful because there are only two transceivers in the application. However, if you want to handle a multipoint application, you just have to define one identity for each mobile system, and this way you can avoid possible collision problems.

RF Command defines the process recipient has to handle. For example, it can be measure or calibration for the mobile system.

Buffer Length defines size of the transmitted **buffer []**.

Stop word defines the end of RF transmission.

For each transmission, the recipient does not handle the RF Command until frame parameters received have been tested.

RF Command can have different values explained in the table below (Figure 12).

RF Command name	role
identification	Send to the base system after each power on or reset
ACK	Send to the transmitter after each good reception of a message
measure_head	Send to the mobile system after each UART measure request
calibrate	Send to the mobile system after each UART calibration request
measure_send	Send to the base system in the same frame as heading

Figure 12 : RF Command Table

A transmission is complete when the owner of the message has received an ACK Command from the recipient so that there is no data losses.

4.2 Hardware Interface

4.2.1 XE1209 - XE8805/05A interface

Figure 13 below shows XE1209 pins characteristics.

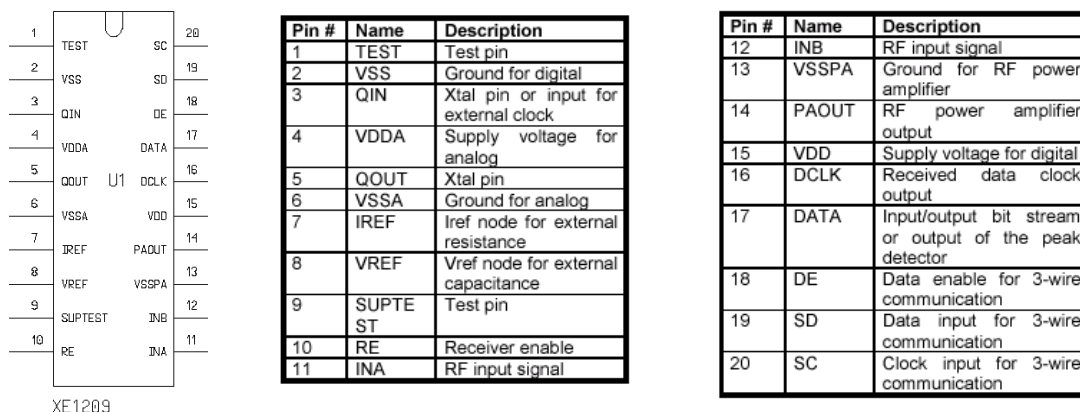

Figure 13 : XE1209 pinout and pin description

XE8805/05A with its large source of interrupt and event permits the interface with a XE1209 RF transceiver in a very simple way.

First, XE1209 needs 3-wire bus for its programming (pins SC, SD and DE). This can be done by using 3 output pin of Port C (PC [0..2]).

To change mode from transmission to reception you just have to put VDD on pin RE of the XE1209. So, a simple connection with the output pin PC[3] is necessary.

Data are transmitted and received on the same pin named DATA. So, you have to use the I / O pin PC[4]. In reception mode, data must be read on rising edge of DCLK. To achieve this, using pin PA[1] seems appropriate since it is one of XE8805/05A event sources. On each PA[1] event (rising edge) it is quite easy to read DATA on pin PC[4].

Of course, XE1209 needs a power supply. You just have to connect XE1209 VDDA and VDD pins to XE8805/05A VDD pin, and VSSPA VSSA and VSS to XE8805/05A VSS pin.

Figure 14 below shows all these connections.

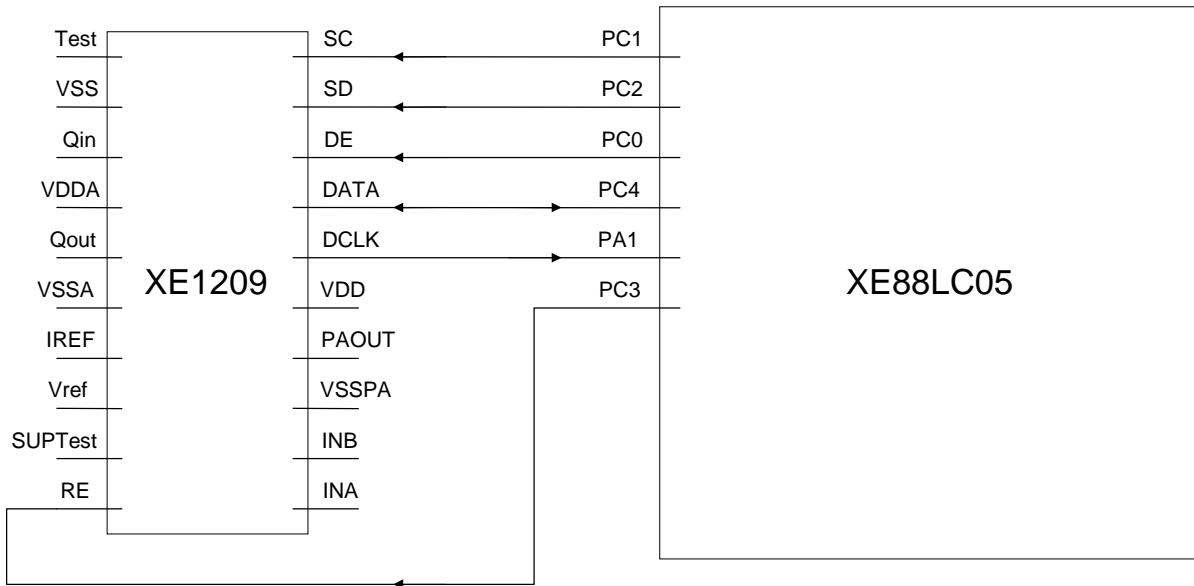

For ease of reading, power supply is not shown on this

Figure 14 :: XE1209 – XE8805/05A interface

4.2.2 XE1201A - XE8805/05A interface

Figure 15 below shows XE1201A pins characteristics.

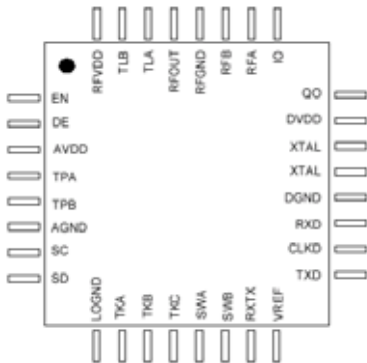

PIN	NAME	DESCRIPTION
1	EN	Chip enable
2	DE	Bus data enable
3	AVDD	Supply voltage for analog
4	TPA	Power amplifier tank circuit
5	TPB	Power amplifier tank circuit
6	AGND	Ground for analog
7	SC	Bus clock
8	SD	Bus data input
9	LOGND	Ground for local oscillator
10	TKA	Oscillator tank circuit
11	TKB	Oscillator tank circuit
12	TKC	Oscillator tank circuit
13	SWA	SAW resonator
14	SWB	SAW resonator
15	RXTX	Receiver / transmitter enable
16	VREF	Voltage stabilizer decoupling
17	TXD	Data input stream
18	CLKD	Received data clock
19	RXD	Received data output
20	DGND	Ground for digital
21	XTAL	Reference oscillator
22	XTAL	Reference oscillator
23	DVDD	Supply voltage for digital
24	QO	Test pin
25	IO	Test pin
26	RFA	RF input
27	RFB	RF input
28	RFGND	Ground for RF
29	RFOUT	Transmitter output
30	TLA	Low noise amplifier tank circuit
31	TLB	Low noise amplifier tank circuit
32	RFVDD	Supply voltage for RF

Figure 15 : XE1201A pinout and description

Contrary to XE1209, XE1201A has separated pins for received data (RXD) and transmitted data (TXD). It also has a chip enable pin (EN).

Except these pins, all others are connected to the XE8805/05A microcontroller, the same way as XE1209. Only some changes appear on port C:

SD is connected to PC[0]
SC is connected to PC[1]
DE is connected to PC[2]
EN is connected to PC[5]
RXTX is connected to PC[6]
TXD is connected to PC[7]

RXD is connected to PA[0] to wake up the microcontroller when there is data received (event generation).
CLKD is connected to PA[1] for event generation on each rising edge of received clock.

Figure 16 below shows XE1201A – XE8805/05A interface.

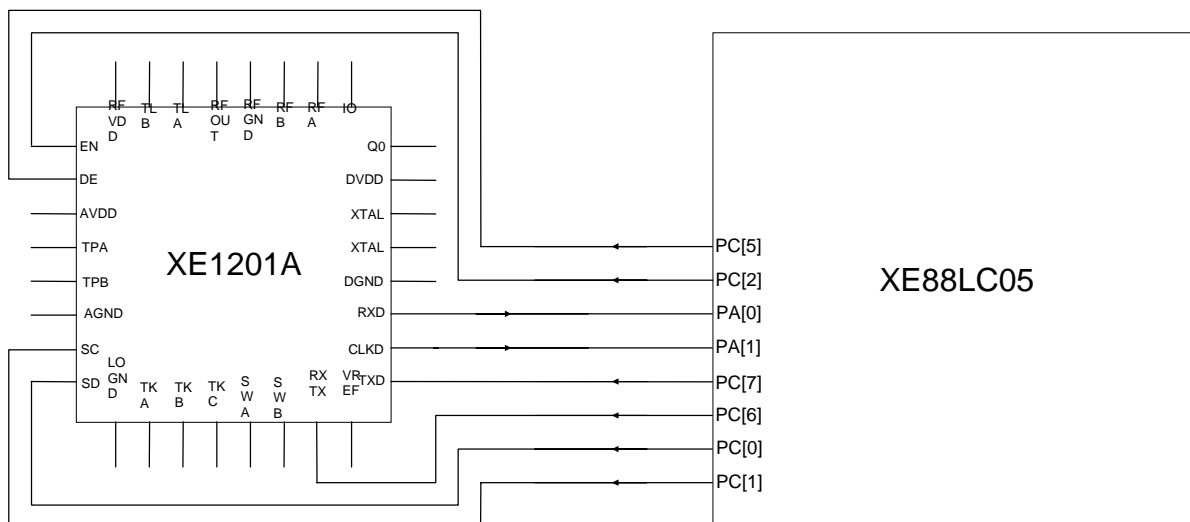

For ease of reading, power supply is not shown on this

Figure 16 : XE1201A – XE8805/05A interface

Note:

RF transceivers need specific design rules. That's why in this application, we used RF modules XM1209 and XM1201 that are existing products. These modules respect RF design rules in order to ensure RF transceiver expected behavior.

4.3 *RF link Flowchart*

According to protocol definition, RF link follows some rules. In our case, the mobile system is defined as SLAVE, and the base system is the MASTER. They have different behavior, so two flowcharts are necessary to describe RF link properties.

The first step of RF link establishment is mobile system identification. At power on or reset, the mobile system sends a frame with RF command = identification. On the other hand, the base system is waiting for identification from the mobile system. If it detects the correct slave_ID with this identification Command, it sends ACK Command to the mobile system.

Once this identification is done, the mobile system turns on reception mode and the base system waits for UART Request.

For system behavior full comprehension, refers to C functions in files "*XE1209Driver.c*" and "*XE1201Driver.c*".

Figures 17 and 18 show respectively SLAVE and MASTER flowchart.

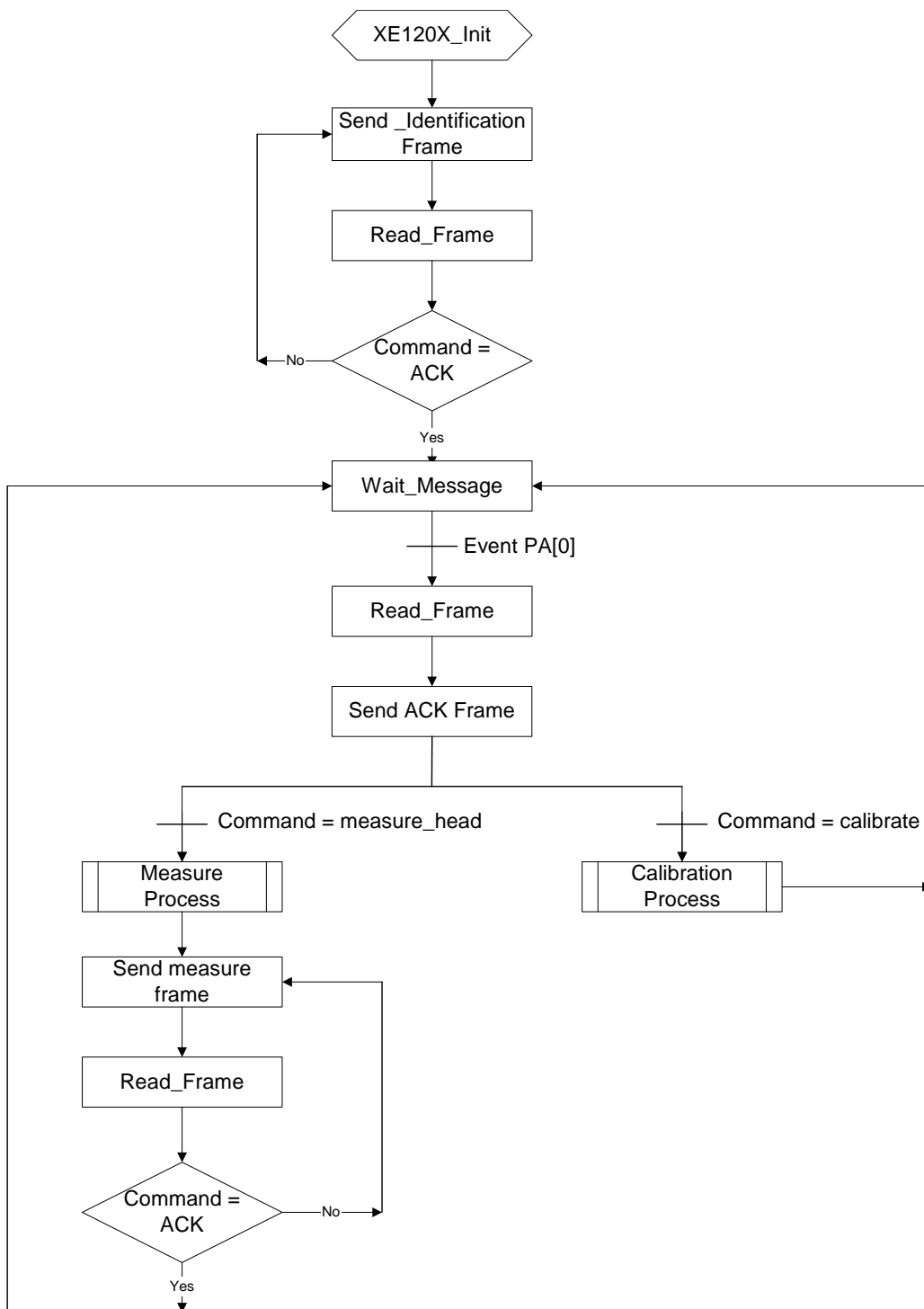
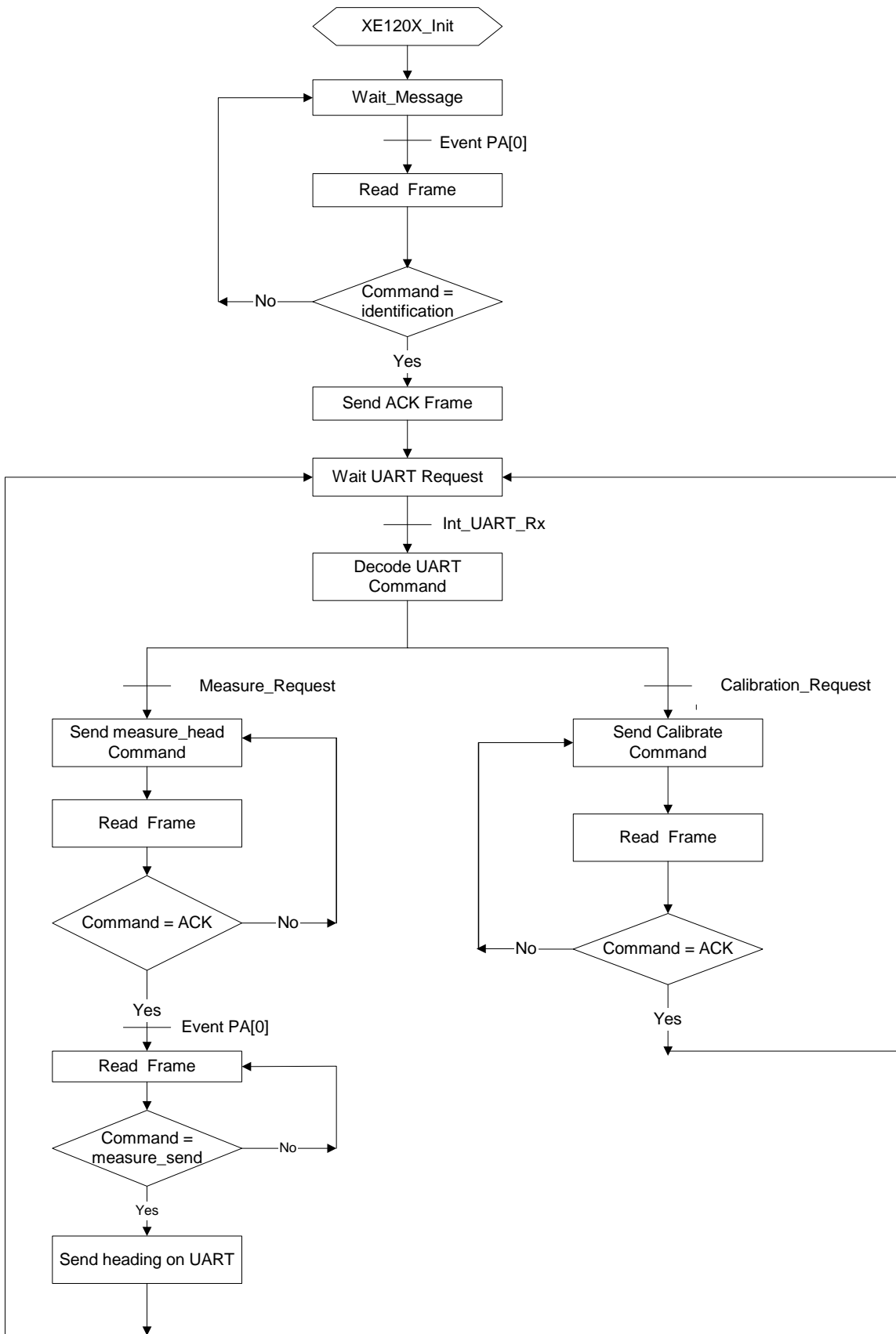

Figure 17 : Slave Flowchart



Master Flowchart

5 System performances

With this system it is possible to obtain one-degree resolution on heading position. Repeatability is about 2 degrees between two calibration phases.

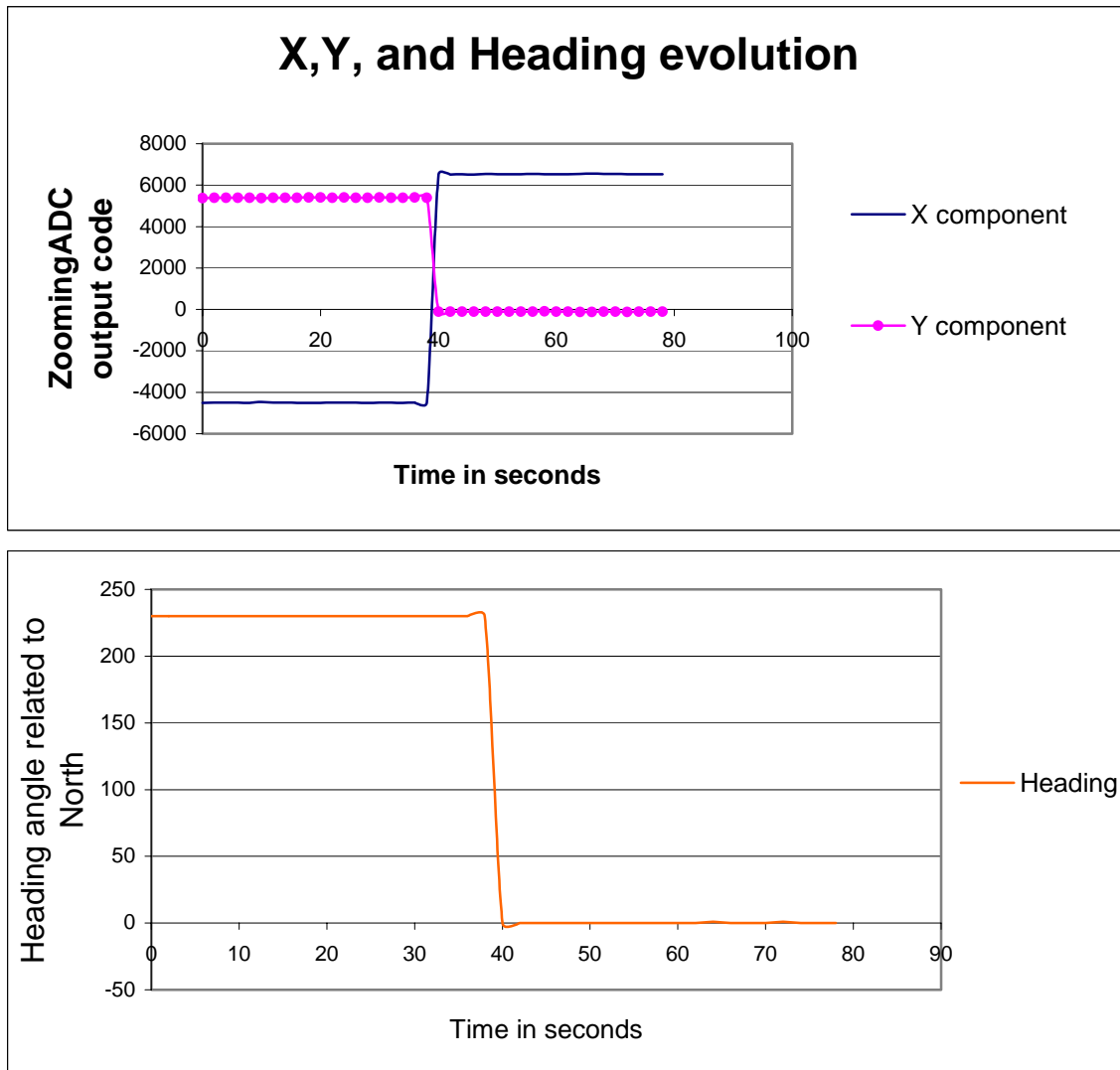

Figure 18 : X & Y measurement evolution

6 Mobile System Schematics

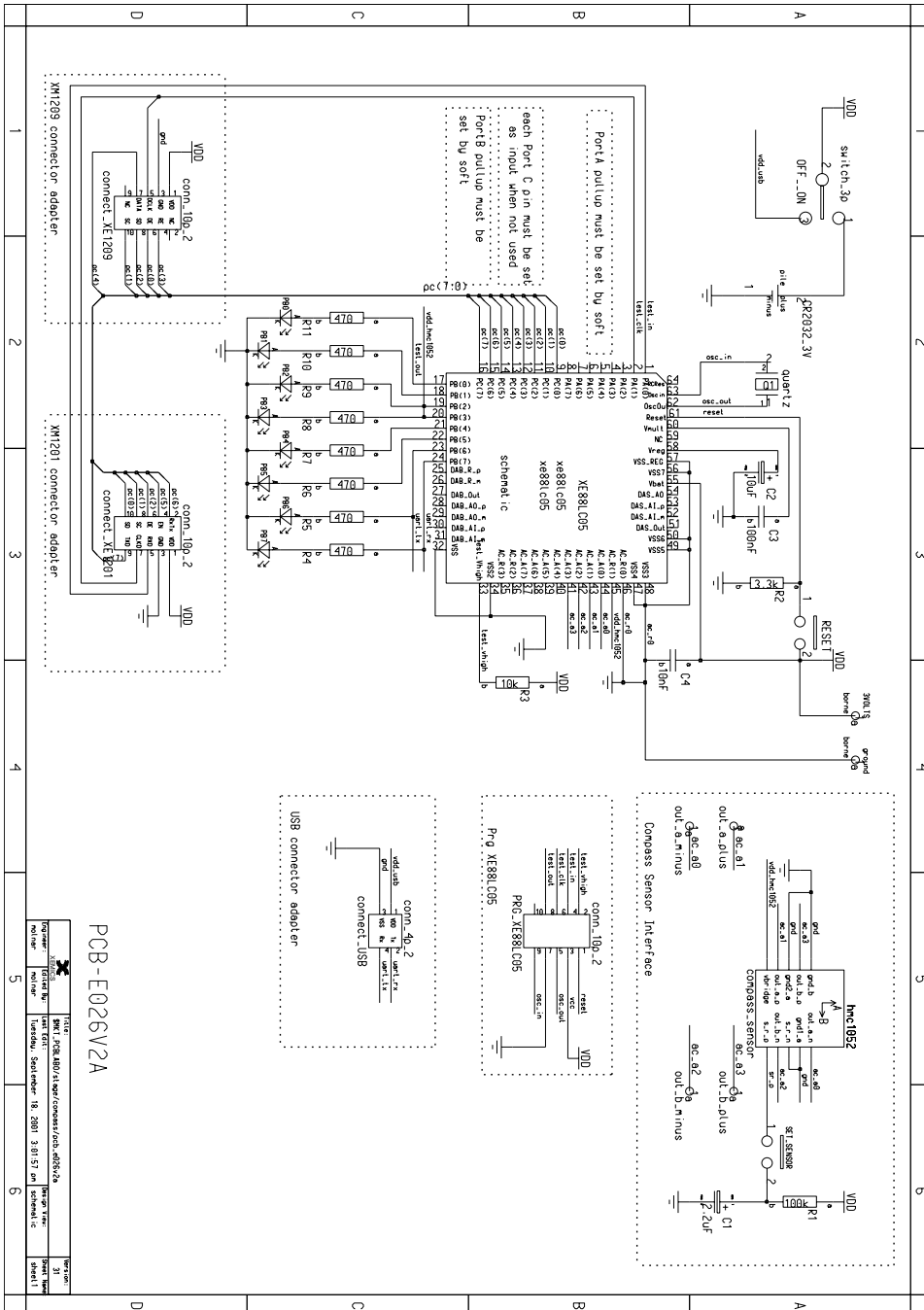

Figure 19 : Wireless Compass schematics

7 Board Description

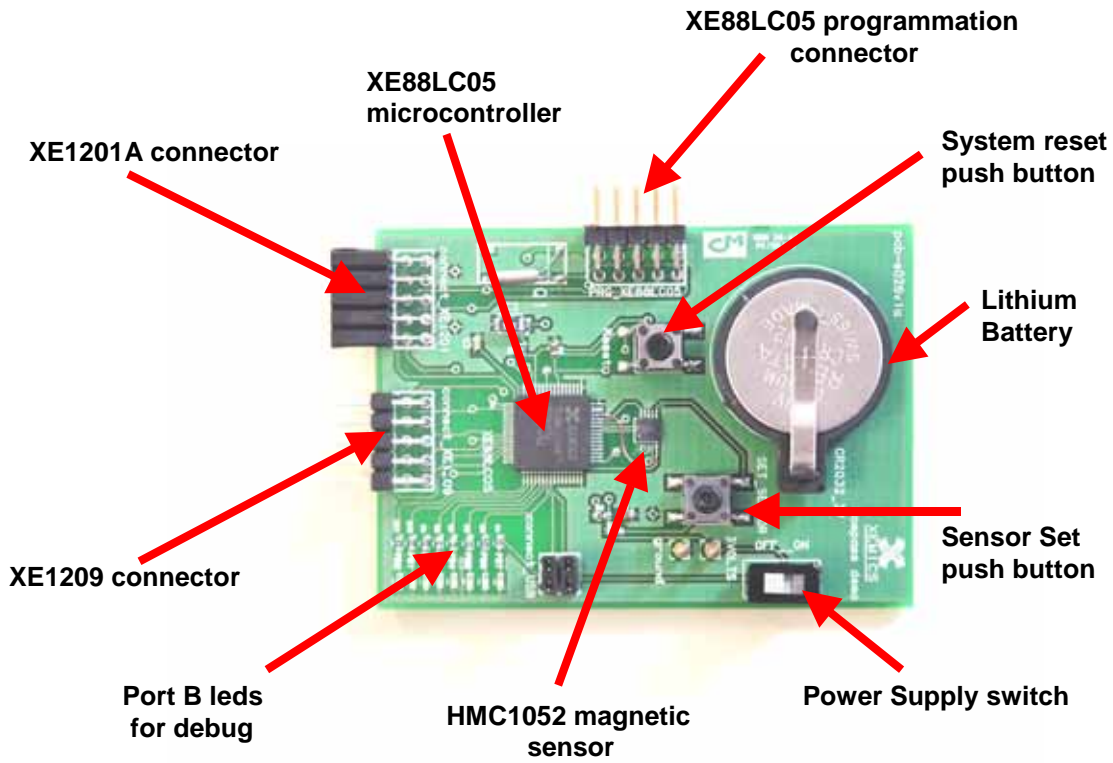

Figure 20 : Wireless Compass Description

Table of Figures

FIGURE 1 : GLOBAL DESCRIPTION.....	3
FIGURE 2 : HMC1052 INTERNAL CIRCUIT	5
FIGURE 3 : HMC1052 TRANSFER FUNCTION.....	6
FIGURE 4 : ZOOM ON HMC1052 TRANSFER FUNCTION WITH BRIDGE OFFSET	6
FIGURE 5 : ZOOMINGADC™ BLOCK DIAGRAM.....	7
FIGURE 6 : ZOOMINGADC™ BLOCK DIAGRAM.....	8
FIGURE 7 : HMC1052-XE8805/05A INTERFACE	9
FIGURE 8 : ZOOMINGADC™ REGISTER MAP	9
FIGURE 9 : MEASURE FUNCTIONS.....	10
FIGURE 10 : MEASUREMENT FLOWCHART	11
FIGURE 11 : RF FRAME CONTENTS	13
FIGURE 12 : RF COMMAND TABLE	14
FIGURE 13 : XE1209 PINOUT AND PIN DESCRIPTION	14
FIGURE 14 : : XE1209 – XE8805/05A INTERFACE	15
FIGURE 15 : XE1201A PINOUT AND DESCRIPTION	16
FIGURE 16 : XE1201A – XE8805/05A INTERFACE.....	16
FIGURE 17 : SLAVE FLOWCHART.....	18
FIGURE 18 : MASTER FLOWCHART.....	19
FIGURE 19 : X & Y MEASUREMENT EVOLUTION	20
FIGURE 20 : WIRELESS COMPASS SCHEMATICS	21
FIGURE 21 : WIRELESS COMPASS DESCRIPTION	22

© Semtech 2006

All rights reserved. Reproduction in whole or in part is prohibited without the prior written consent of the copyright owner. The information presented in this document does not form part of any quotation or contract, is believed to be accurate and reliable and may be changed without notice. No liability will be accepted by the publisher for any consequence of its use. Publication thereof does not convey nor imply any license under patent or other industrial or intellectual property rights. Semtech. assumes no responsibility or liability whatsoever for any failure or unexpected operation resulting from misuse, neglect improper installation, repair or improper handling or unusual physical or electrical stress including, but not limited to, exposure to parameters beyond the specified maximum ratings or operation outside the specified range.

SEMTECH PRODUCTS ARE NOT DESIGNED, INTENDED, AUTHORIZED OR WARRANTED TO BE SUITABLE FOR USE IN LIFE-SUPPORT APPLICATIONS, DEVICES OR SYSTEMS OR OTHER CRITICAL APPLICATIONS. INCLUSION OF SEMTECH PRODUCTS IN SUCH APPLICATIONS IS UNDERSTOOD TO BE UNDERTAKEN SOLELY AT THE CUSTOMER'S OWN RISK. Should a customer purchase or use Semtech products for any such unauthorized application, the customer shall indemnify and hold Semtech and its officers, employees, subsidiaries, affiliates, and distributors harmless against all claims, costs damages and attorney fees which could arise.

Contact Information

Taiwan	Tel: 886-2-2748-3380 Fax: 886-2-2748-3390	Switzerland	Tel: 41-32-729-4000 Fax: 41-32-729-4001
Korea	Tel: 82-2-527-4377 Fax: 82-2-527-4376	United Kingdom	Tel: 44-1794-527-600 Fax: 44-1794-527-601
Shanghai	Tel: 86-21-6391-0830 Fax: 86-21-6391-0831	France	Tel: 33-(0)169-28-22-00 Fax: 33-(0)169-28-12-98
Japan	Tel: 81-3-6408-0950 Fax: 81-3-6408-0951	Germany	Tel: 49-(0)8161-140-123 Fax: 49-(0)8161-140-124

Semtech International AG is a wholly-owned subsidiary of Semtech Corporation, which has its headquarters in the U.S.A