AN8000.11 Application Note

Wireless Gas Sensor

Abstract

This application note describes a wireless gas sensor module. The application is based on an 8 bit micro controller with a 16+10 bit ZoomingADC™ on chip and a 433MHz transceiver. The sensor is a semi-conducting metal oxide layer gas sensor.

The system consists of two modules; one mobile station with the sensor and one base station for the communication with a PC. As the mobile station is battery powered ultra low power consumption is required. Therefore, the low power micro controller and the low power transceiver used in this application are perfectly suitable.

Table of contents

1	INTRODUCTION	5
2	GENERAL DESCRIPTION	5
2.1	BLOCK DESCRIPTION	5
2.2	FUNCTIONAL DESCRIPTION	6
2.3	COMPONENTS DESCRIPTION	6
2.3.1	<i>Gas Sensor</i>	<i>6</i>
2.3.2	<i>XE8805/05A micro-controller</i>	<i>6</i>
2.3.3	<i>XE1201A Transceiver (300 - 500 MHz)</i>	<i>6</i>
3	SENSOR INTERFACE	7
3.1	MSG3000 CHARACTERISTICS	7
3.1.1	<i>Sensor Supply Voltages</i>	<i>8</i>
3.2	XE8805/05A DAC CHARACTERISTICS	9
3.2.1	<i>Implementation of the DAC_bias function</i>	<i>9</i>
3.3	XE8805/05A ZOOMINGADC™ CHARACTERISTICS	10
3.3.1	<i>Configuration of the ZoomingADC™ for Gas Sensor Application</i>	<i>10</i>
3.4	HARDWARE INTERFACE	12
3.5	SOFTWARE DESCRIPTION	13
3.5.1	<i>Mobile sensor system</i>	<i>13</i>
3.5.2	<i>Base System Flowchart</i>	<i>14</i>
3.6	RF TRANSCEIVER INTERFACE	15
3.7	PROTOCOL DESCRIPTION	15
3.8	HARDWARE INTERFACE	16
3.8.1	<i>XE1201A - XE8805/05A interface</i>	<i>16</i>

Table of Figures

FIGURE 1: GLOBAL DESCRIPTION..... 5

FIGURE 2: MSGS3000 SCHEMATIC 7

FIGURE 3 BELOW SHOWS THE SENSOR TRANSFER FUNCTION FOR ALCOHOL. 7

FIGURE 3: MSGS3000 TRANSFER FUNCTION FOR ALCOHOL 7

FIGURE 4: VH AND VS VOLTAGE PATTERN 8

FIGURE 5: GENERAL BLOCK DIAGRAM..... 9

FIGURE 7: ZOOMINGADC™ BLOCK DIAGRAM..... 10

FIGURE 8: ZOOMINGADC™ DECIMAL OUTPUT VERSUS VOLTAGE INPUT 11

FIGURE 9: HARDWARE INTERFACE BETWEEN XE88LC05 AND MSGS3000 GAS SENSOR 12

FIGURE 10: FLOWCHARTS OF MOBILE SENSOR APPLICATION..... 13

FIGURE 11: FLOWCHART FOR BASE SYSTEM APPLICATION 14

FIGURE 12: RF FRAME CONTENTS 15

FIGURE 13: XE1201A PIN OUT AND DESCRIPTION 16

FIGURE 14: XE1201A – XE88LC05 INTERFACE 17

1 Introduction

The purpose of this application note is to explain the different steps needed, to build a wireless gas sensor based on XE8805/05A capabilities. This application note demonstrates XE8805/05A performances as both sensing machine and RF communication driver. To implement the gas sensor function, we used a semi-conductor gas sensor. For the RF communication the XE1201A (UHF) radio transceiver is used.

The system can be built with two XE8805/05A ProStart modules and two XE1201A RF modules from Semtech and the MSG3000 gas sensor from Microsens.

2 General Description

2.1 Block Description

Figure 1 shows a wireless gas sensing machine. This system is composed of two different parts:

- The mobile station which includes the gas sensor
- The base station which is connected to a PC

The mobile system includes the MSGS3000 gas sensor, a XE1201A transceiver and a XE8805/05A micro-controller.

The base system includes a transceiver XE1201A, a XE88LC05 micro-controller and a PC.

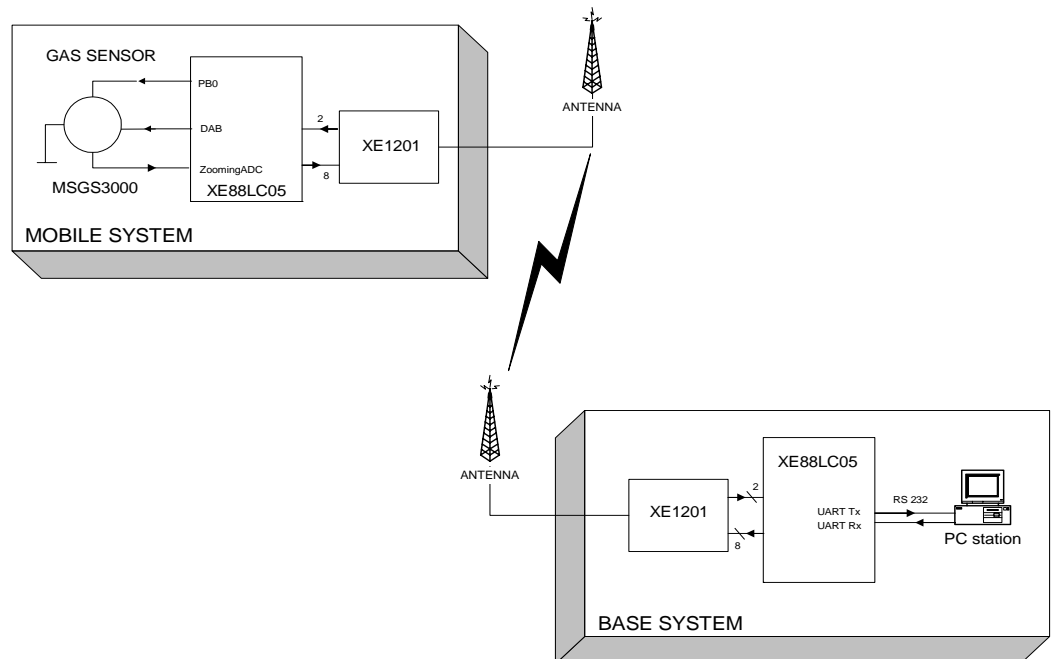

Figure 1: Global Description

2.2 Functional Description

The mobile system micro-controller activates the gas sensor every five seconds. After the gas sensor has been stimulated, it measures the relevant gas quantities. As soon as the measurement is finished, the value is captured by the micro-controller's ZoomingADC™. Finally, the data is sent to the base system via the XE1201A transceiver.

The RF unit at the base system is waiting for a matching data frame. The arriving data will then be sent to the PC com port via a UART connection. The PC application calculates and displays the data using the following equation:

$$\text{Signal} = \text{Offset} + \text{Gain} * \text{Code} + \text{Gain2} * (\text{Code})^2$$

Code is the digital value coming from the ZoomingADC. The user can customise the **Offset**, **Gain** and **Gain2** parameters on the PC.

2.3 Components description

2.3.1 Gas Sensor

A semi-conducting metal oxide layer characterises the low power MSG3000 sensor. The measurements of specific oxidising or reducing gases are based on reversible conductivity change of the sensing element at an appropriate working temperature.

For more information about this product, consult <http://www.microsens.ch>, the microsens web site.

2.3.2 XE8805/05A micro-controller

The XE8805/05A is an ultra low-power micro-controller unit, associated with a versatile analog-to-digital converter including programmable offset and gain pre-amplifier. This acquisition chain, the ZoomingADC™ also includes an analog multiplexer (AMUX) allowing selection of four differential inputs channels or seven common referenced signal paths.

As the XE88LC05 has several sources of interrupts and events, it can directly read the XE1201A data output and synchronised clock.

2.3.3 XE1201A Transceiver (300 - 500 MHz)

The XE1201A is a half-duplex FSK transceiver for operation in the 433 MHz ISM band (optimised) and in the 300-500 MHz band. The range of the XE1201A is between 200 and 300 meters. The modulation used is the Continuous Phase, 2 level Frequency Shift Keying (CPFSK). The direct conversion (zero-IF) receiver architecture enables on-chip channel filtering.

The XE1201A includes a bit synchroniser so that glitch free data with synchronised clock can directly be read by a low cost / low complexity micro-controller. The transmitted power level can also be controlled via the bus.

For more information on XE8000 micro-controller series and XE1200 RF transceiver series, please consult the Semtech website.

3 Sensor Interface

3.1 MSGS3000 characteristics

The MSGS3000 contains two main parts. One part is the sensitive element, which consists of a semi-conducting metal oxide layer. The other part is an integrated heater where the thin sensitive metal oxide layer is deposited. The gas selectivity of the sensor is determined by superficial or bulk doping of the semi-conducting metal oxide with metal catalysts. Different types of gases can be detected by adjusting the working temperature of the sensor.

Figure 2 below shows the schematic of the gas sensor, with the heating and sensing parts.

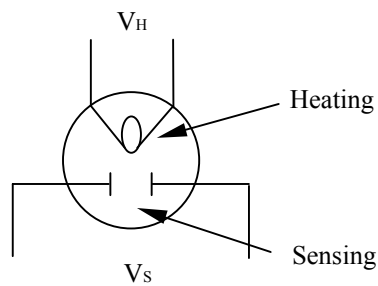

Figure 2: MSGS3000 schematic

Figure 3 below shows the Sensor transfer function for Alcohol.

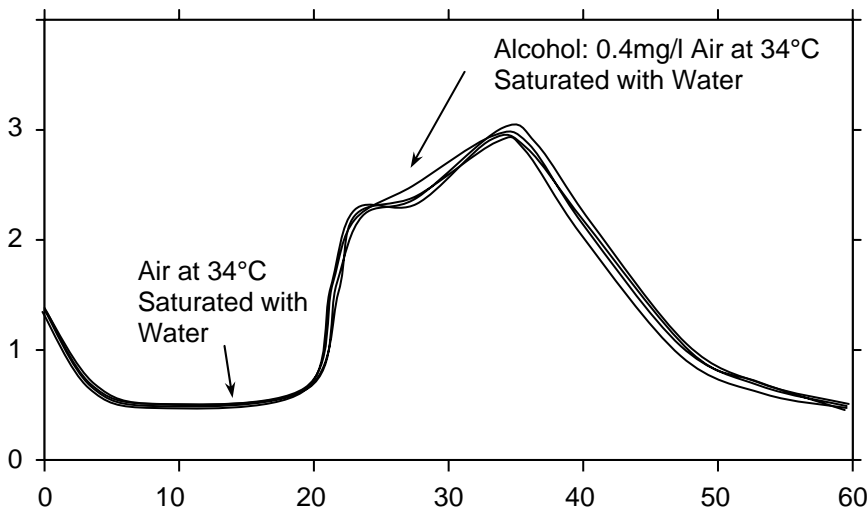

Figure 3: MSGS3000 Transfer Function for Alcohol

3.1.1 Sensor Supply Voltages

An appropriate working temperature has to be achieved in order to measure specific oxidising or reducing gases. This particular working temperature is achieved with the voltage V_H connected to the heater of the sensor. Figure 4 below, shows the pattern of a specific heating voltage V_H to measure the alcohol concentration in air.

To create this voltage pattern the DAC function of the XE8805/05A is used. The power supply voltage V_S for the sensor is generated by the digital output pin PB0. See figure 4 below.

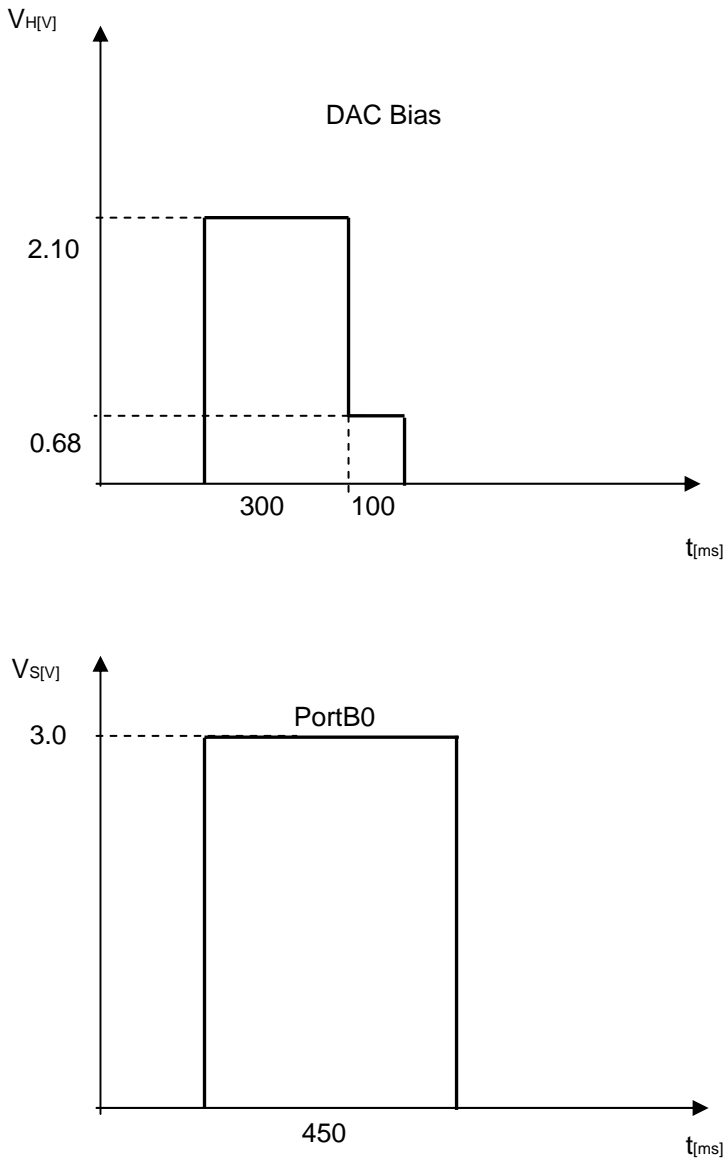

Figure 4: V_H and V_S voltage pattern

3.2 XE8805/05A DAC characteristics

The XE8805/05A has two digital to analog converters (DAC)s: a signal DAC able to pass a 4KHz signal with 10bits precision, and a bias DAC, able to output 10mA to bias a resistive bridge sensor. Both are DACs formed from a generic DAC and an amplifier. This makes current and voltage drive possible and gives the user freedom to choose the preferred filtering scheme. For more details on the DAC performances, consult the TN8000.03 on the Semtech website.

3.2.1 Implementation of the DAC_bias function

The DAC peripheral is used together with the onboard amplifier in order to deliver the current required by the integrated heater of the MSG3000.

The figure below shows the block diagram of the peripheral. It consists of a control block that manages all communication with the CPU, sets the configuration of the peripheral and implements the different test modes. The DAC converts the digital data in an analog output signal with an amplifier that can output up to 10mA.

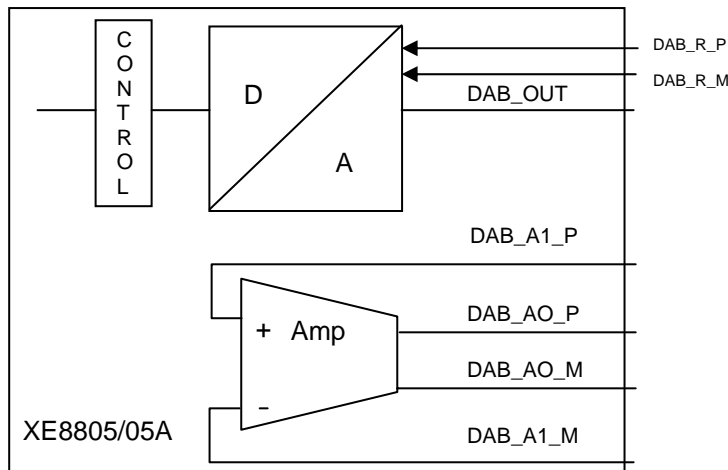

Figure 5: General block diagram

3.3 XE8805/05A ZoomingADC™ characteristics

XE8805/05A ZoomingADC™ is appropriate for this type of measurement, thanks to its offset compensation capabilities.

See below Figure 5 that shows XE88LC05 ZoomingADC™ block diagram.

ZoomingADC

The fully differential acquisition chain is formed of a programmable gain (0.5 - 1000) and offset amplifier and a programmable speed and resolution ADC (example: 12 bits at 4 kHz, 16 bits at 1 kHz). It can handle inputs with very low full scale signal and large offsets.

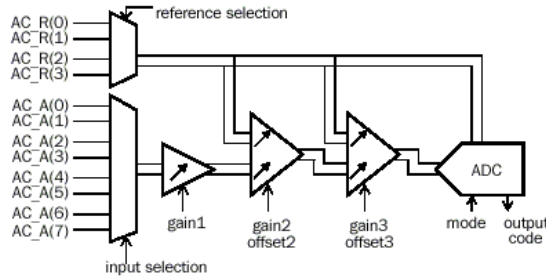

Acquisition channel block diagram

Input selection is made from 1 of 4 differential pair or 1 of seven single signal versus AC_A(0). Reference is chosen from the 2 differential references.

The gain of each amplifier is programmed individually. Each amplifier is powered on and off on command to minimize the total current requirement. All blocks can be set to low frequency operation and lower their

Figure 7: ZoomingADC™ block diagram

In our case, the output of the sensor is connected to the first (AC_A0–AC_A1) input channel of ZoomingADC™ and all PGAs are enabled. The AD converter is used to convert the differential input signal into a 16 bits 2's complement output format. For more details on ZoomingADC™ performances, see AN8000.05 on the Semtech website.

3.3.1 Configuration of the ZoomingADC™ for Gas Sensor Application

The following parameters have to be known in order to be able to calculate the configuration of the acquisition chain.

- **Power supply of sensor**
Vsupply = 3 V
- **Reference voltage of ZoomingADC**
Vref = 3V
- **Full scale span of sensor output**
Vout = 0.7V

Calculation of the necessary gain to cover ADC full scale:

$$\text{Gain} = \frac{V_{\text{ref}}/2}{|V_{\text{out}}(\text{max})|} = \frac{1.5V}{0.35V} \cong 4.29$$

Calculation of the offset compensation

The output of the sensor is 0V if the air is not saturated with alcohol and 0.7V when the air is saturated with alcohol. In order to obtain the full scale output range of the ZoomingADC™ an offset has to be applied so that an input voltage of 0V equals to an output code of -32768 and an input voltage of 0.7V equals to an output of 32767.

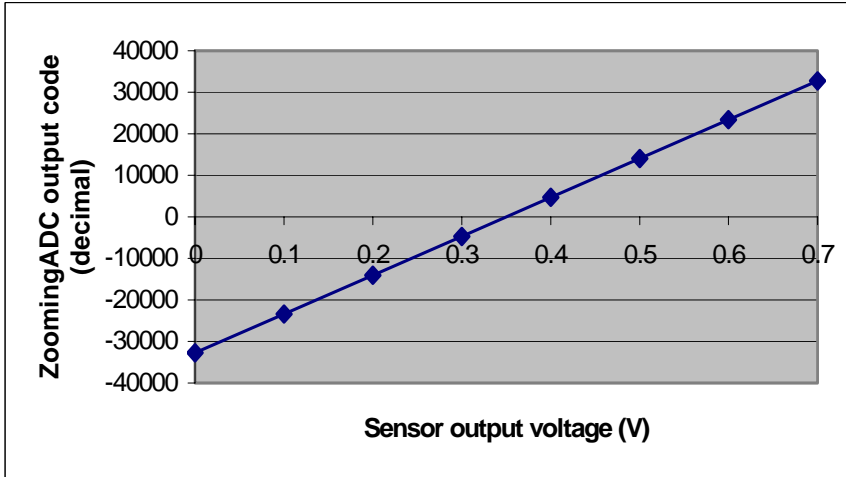

Figure 8: ZoomingADC™ decimal output versus voltage input

The graphic above is shifted to $V_{out}/2 = 0.35V$. Therefore, an offset has to be calculated to remove this shift.

$$V_{inADC} = GD1 * GD2 * GD3 * V_{in} - (Goff3 + Goff2 * GD3) * V_{ref}$$

This formula gives the voltage at the input of the ADC. The offset is given at the input of the acquisition chain. The gain has to be multiplied by the input voltage. Therefore $V_{inADC} = 0V$ because the offset has to be corrected when V_{in} equals 0.35V

$$V_{in} * Gain = (Goff3 + Goff2 * GD3) * V_{ref}$$

This formula equals

$$V_{in} * Gain = Goff3 * V_{ref}$$

with $Goff2 = 0$ since the offset of the PGA2 is not enabled.

$$Goff3 = \frac{V_{in} * Gain}{V_{ref}} \cong \frac{0.35V * 4.29}{3V} \cong 0.5$$

$$Goff3 = 0.5 \Rightarrow Goff3 = \frac{PGA3_off(5:0)}{12}$$

$$\Rightarrow PGA3_off = 6 = 0x06H$$

0x06H is the value which has to be written into the "RegACCfg4" register

3.4 Hardware Interface

Figure 4 below shows the hardware interface between the MSGS3000 gas sensor and the XE8805/05A microcontroller.

The sensor voltage V_s is generated by the digital output PB0. To fulfil the current requirements of the sensors heating element, the DAC output DAC DAB_OUT has to be connected to the amplifier input DAB_A1_P. The amplified DAC output DAB_A0_M is connected directly to the sensors heating element. The gas sensor output voltage V_o is captured by the ZoomingADC™ input AC_A1.

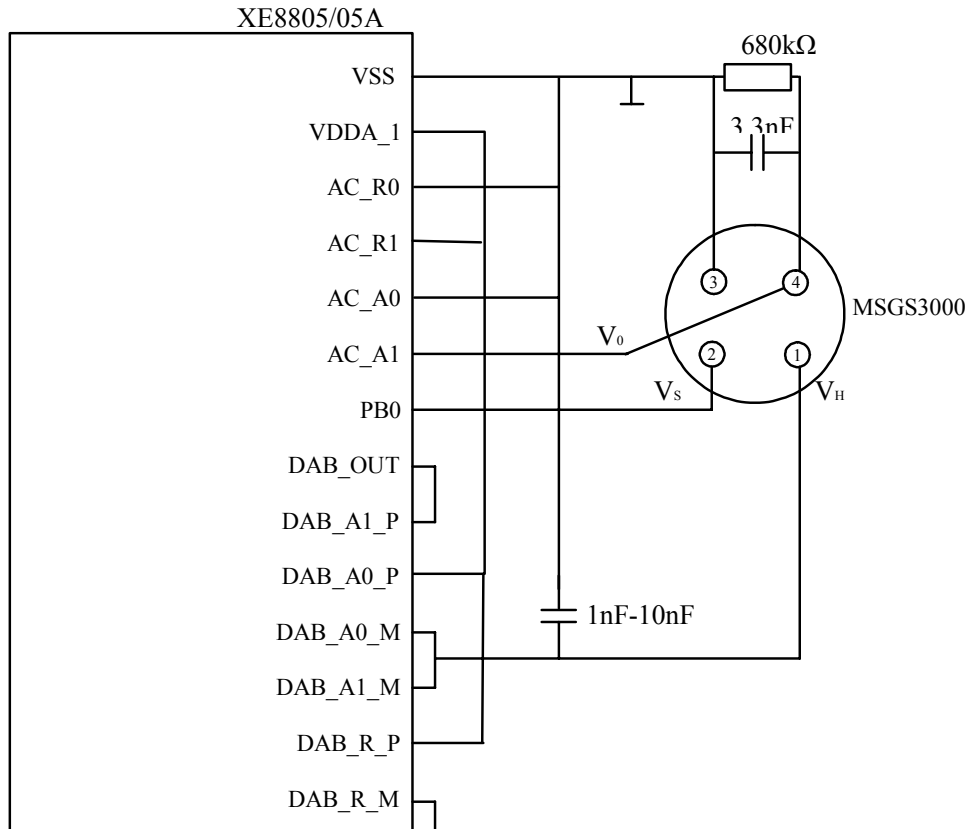

Figure 9: Hardware Interface between XE8805/05A and MSGS3000 Gas Sensor

3.5 Software description

3.5.1 Mobile sensor system

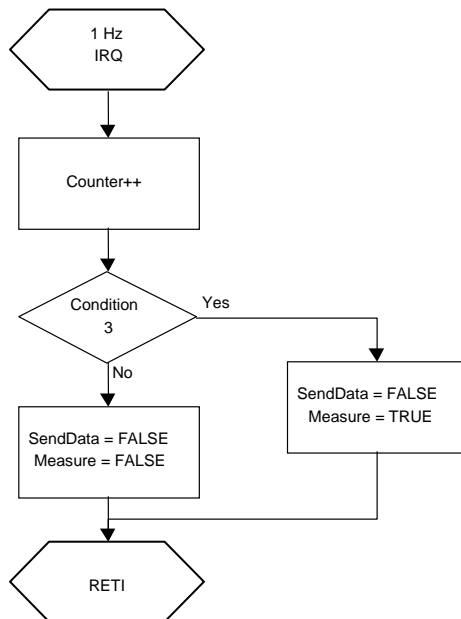
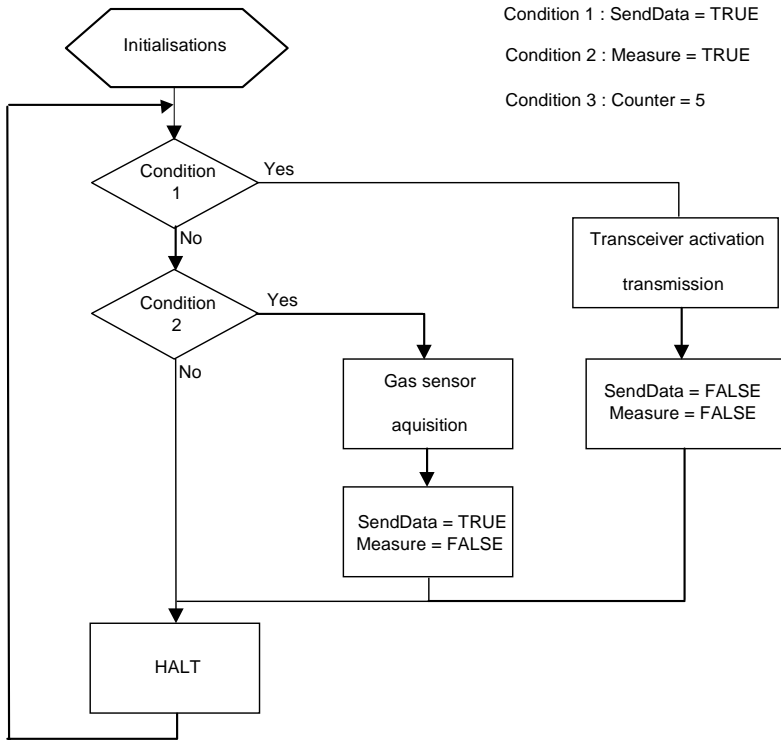

Figure 10: Flowcharts of mobile sensor application

3.5.2 Base System Flowchart

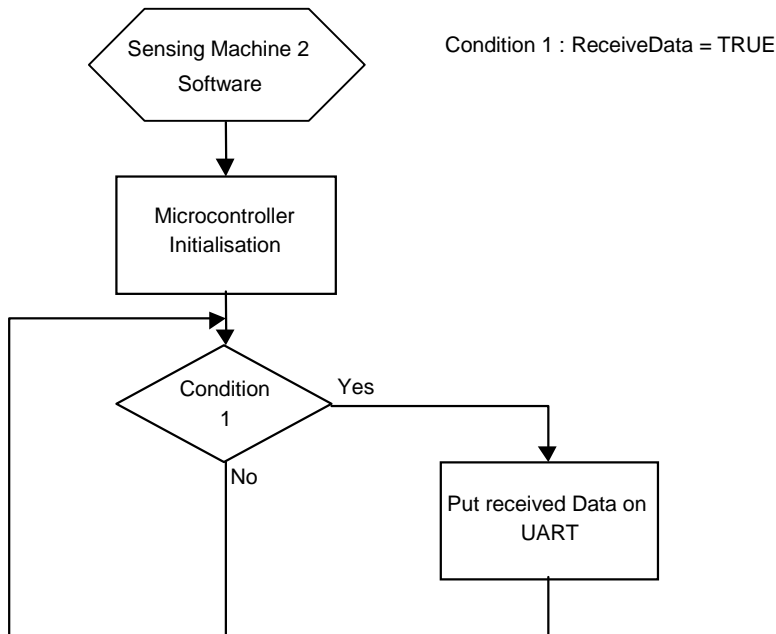

Figure 11: Flowchart for base system application

3.6 RF Transceiver Interface

The RF link is achieved with the Semtech RF transceiver XE1201A. The programming interface between the micro controller and the XE1201A is established via a 3-wire bus. In our case, XE1201A (300–500 MHz band) is used to handle RF link depending on the frequency and on the range one wants to use for RF communication.

3.7 Protocol Description

Figure 12 below describes RF frame contents.

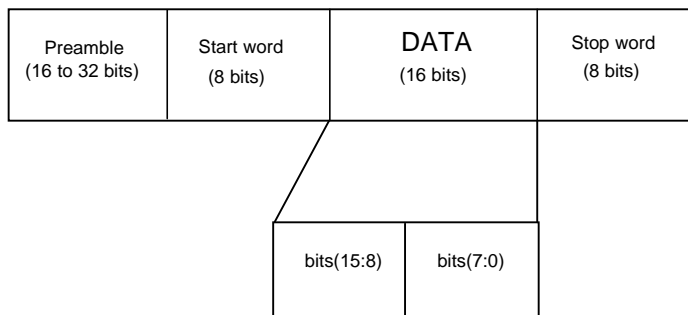

Figure 12: RF Frame contents

Preamble is a sequence of “0” and “1” use to synchronise data and clock at transceiver output.

Start word defines the beginning of RF transmission.

Data 16 bit value from the ZoomingADC™

Stop word defines the end of RF transmission.

3.8 Hardware Interface

3.8.1 XE1201A - XE8805/05A interface

Figure 13 below shows XE1201A pins characteristics.

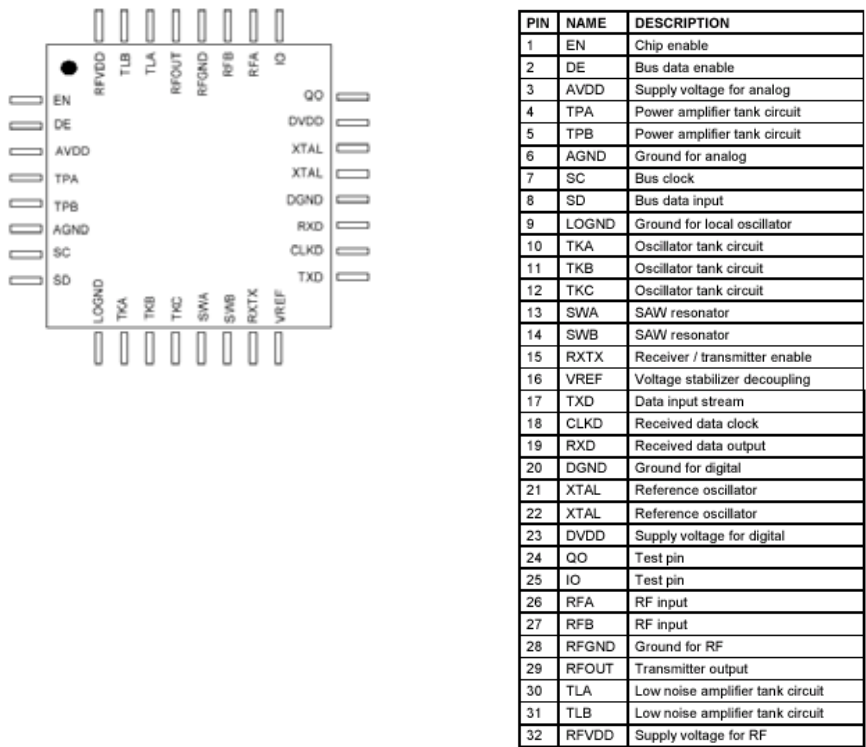
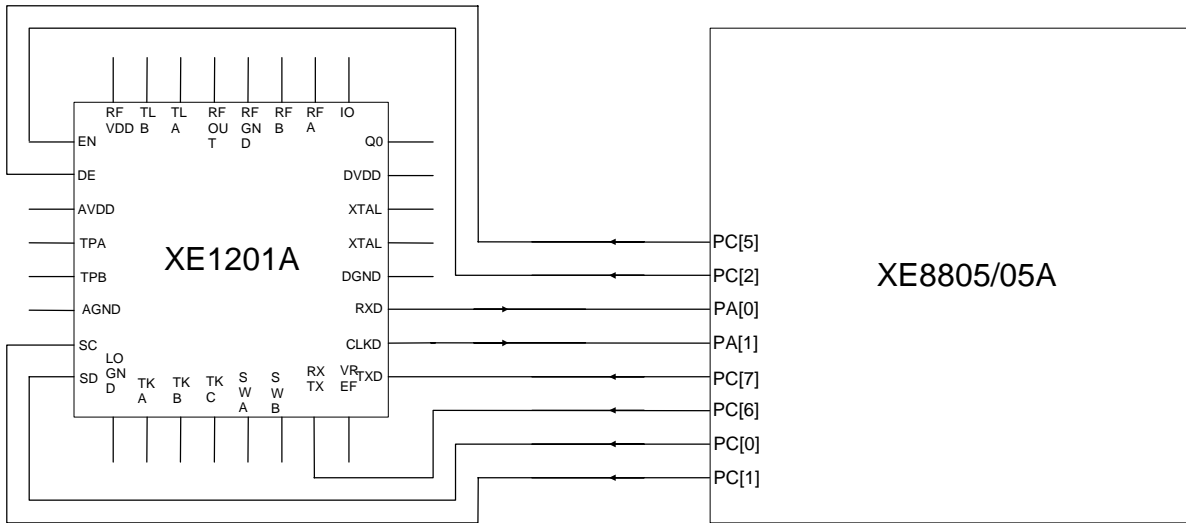

Figure 13: XE1201A pin out and description

The XE1201A has separated pins for received data (RXD) and transmitted data (TXD) and a chip enable pin (EN). RXD is connected to PA[0] to wake up the micro-controller when data is received (event generation). CLKD is connected to PA[1] for event generation on each rising edge, of the received clock.

Figure 14 below shows XE1201A – XE8805/05A interface.



For more visibility, the power supply is not illustrated

Figure 14: XE1201A – XE8805/05A interface

Note:

RF transceivers need specific design rules. That's why in this application, we used the RF module XE1201 which is an existing product. These modules respect some RF design rules in order to ensure RF transceiver expected behaviour.

You can find a XE1201A reference design on the Semtech web site:
<http://www.semtech.com>

© Semtech 2006

All rights reserved. Reproduction in whole or in part is prohibited without the prior written consent of the copyright owner. The information presented in this document does not form part of any quotation or contract, is believed to be accurate and reliable and may be changed without notice. No liability will be accepted by the publisher for any consequence of its use. Publication thereof does not convey nor imply any license under patent or other industrial or intellectual property rights. Semtech. assumes no responsibility or liability whatsoever for any failure or unexpected operation resulting from misuse, neglect improper installation, repair or improper handling or unusual physical or electrical stress including, but not limited to, exposure to parameters beyond the specified maximum ratings or operation outside the specified range.

SEMTECH PRODUCTS ARE NOT DESIGNED, INTENDED, AUTHORIZED OR WARRANTED TO BE SUITABLE FOR USE IN LIFE-SUPPORT APPLICATIONS, DEVICES OR SYSTEMS OR OTHER CRITICAL APPLICATIONS. INCLUSION OF SEMTECH PRODUCTS IN SUCH APPLICATIONS IS UNDERSTOOD TO BE UNDERTAKEN SOLELY AT THE CUSTOMER'S OWN RISK. Should a customer purchase or use Semtech products for any such unauthorized application, the customer shall indemnify and hold Semtech and its officers, employees, subsidiaries, affiliates, and distributors harmless against all claims, costs damages and attorney fees which could arise.

Contact Information

Taiwan	Tel: 886-2-2748-3380 Fax: 886-2-2748-3390	Switzerland	Tel: 41-32-729-4000 Fax: 41-32-729-4001
Korea	Tel: 82-2-527-4377 Fax: 82-2-527-4376	United Kingdom	Tel: 44-1794-527-600 Fax: 44-1794-527-601
Shanghai	Tel: 86-21-6391-0830 Fax: 86-21-6391-0831	France	Tel: 33-(0)169-28-22-00 Fax: 33-(0)169-28-12-98
Japan	Tel: 81-3-6408-0950 Fax: 81-3-6408-0951	Germany	Tel: 49-(0)8161-140-123 Fax: 49-(0)8161-140-124

Semtech International AG is a wholly-owned subsidiary of Semtech Corporation, which has its headquarters in the U.S.A