

---

# AN8000.08

## Application Note

---

*Guidelines on how to build a barometer around the XE8805/05A and a piezoresistive pressure sensor*

## Introduction

The aim of this application note is to describe a barometer built around a XE8805/05A microcontroller. To implement this application, the following elements are needed:

- Pro-Start (Programmer and Starter-Kit for the XE8000 series)
- CoolRIDE (Software development environment for XE8000 series, included in the Pro-Start)
- XE8805/05AM (MTP version of the XE8805/05A, included in the Pro-Start)
- Pressure sensor (AM 5801 AV Intersema)
- LCD display (2 lines X 16 rows)

## Application bloc diagram

This bloc diagram represents the connection between the XE8805/05A, the LCD display and pressure sensor.

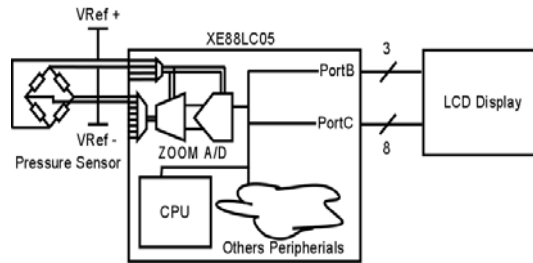

Figure 1

## Microcontroller interface

To build this barometer, you must interface the XE8805/05A with the pressure sensor and the LCD display.

## Pressure sensor overview

The pressure sensor is based on micro-machined silicon with piezoresistive elements. The device produces differential output voltages proportional to the applied pressure.

Most piezoresistive pressure sensors intended for OEM users are compatible for this application. Since the system is fully programmable, any other sensor can replace the model taken here. The table below presents the main parameters need to set the interface. Values have been taken from the Intersema sensor.

Table 1

Parameter	Units	Typical	Min	Max
Pressure Range	m Bar	-	0	100
	kPa	-	0	100
Supply current	Is	10.00	0	20
Supply Voltage	V	1.5	0	3-0
Full-scale output at 10V bias	mV	50.0	49.5	50.05
Sensitivity at 10V bias	mV	0.5	-	-
Output impedance	kΩ	2.5	2	3.8

The utilized sensor is compensated and calibrated in temperature. Some sensors are smaller, yet neither of these are compensated or calibrated. Software within the XE8805/05A can be used to correct the sensor's linearity.

Pressure is applied to the top of the die and a single pressure port is provided. The optimum pressure media is non-conductive and optimally clean dry air.

For a barometer application, the output of the sensor must have a linear response over the expected pressure range of 850-1050 mBar (85-105 kPa). The sensor is designed to measure pressure with respect to a sealed vacuum in the sensor cavity.

The model used has a constant voltage compensated resistor network. The advantage here is that the device does not need to interface with a variable gain instrumentation amplifier

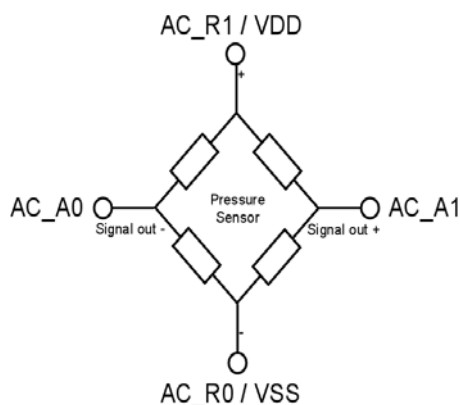

**Figure 2. The Piezorative Pressure Sensor Interface**

The following below presents the necessary guidelines to interface the sensor with the XE8000 product.

Any differential resistive sensor is well suited to the XE8805/05A given that no external specific additional device is required thanks to the integrated programmable gain and offset signal-conditioning circuitry. Gain and offset compensation is executed within the XE8805/05A by programming the parameters of the analog chain.

In most common systems, the output of the sensor must be converted to a ground referenced analog voltage. With the XE8805/05A the signal is treated fully differentially on the analog input chain.

In order to minimize variations that could affect the accuracy of the output signal, the reference voltage of the A/D converter and the amplifiers is ratio-metric to the power supply. The voltage of the demo board operated at 2.4V provides the sensor supply voltage.

The sensor's output is ratio-metric to the supply voltage. With a sensitivity of 0.05mV/mBar (0.5 mV/kPa) at 10 V, it will result in 0.012 mV/mBar at 2.4V.

**Zooming ADC**

In general, concepts using the maximum resolution of the A/D have the power supply as full-scale. It is advisable for a barometer to have a pressure range of 850-1050 mBar.

In addition, the sensor is driven by a constant voltage supply that is usually easier to generate than constant current sources. This is the useful range that is converted to the maximum resolution of the ADC using the zoom included in the acquisition chain.

**Figure 3. ADC Conversion**

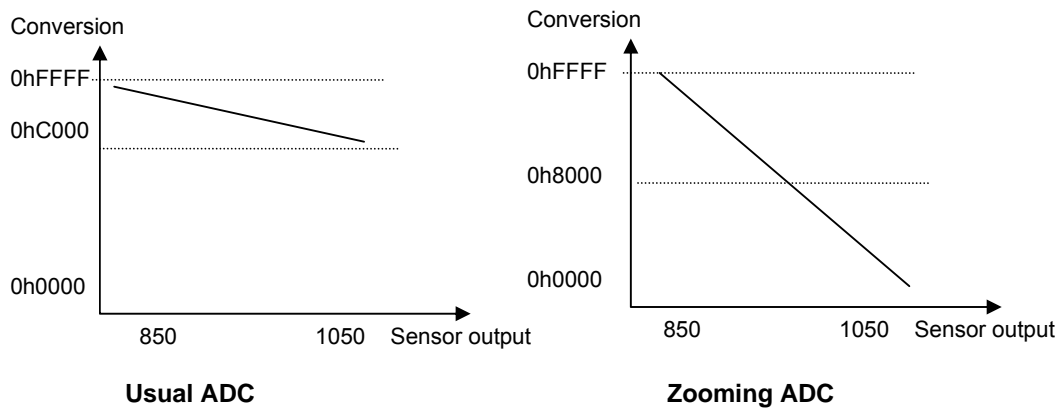

The gain made in the amplification stage of the zooming ADC increases the signal so that the value of the LSB of the ADC referring to the input of the circuit is smaller. This enables it to detect a very small signal variation. The XE8805/05A pre-amplifier maximum gain (-1000) is such that the ADC can measure the input signal down to the noise of the pre-amplifier.

In order to adapt the sensor output as well as possible to the span of the A/D, the output signal of the sensor is amplified and offset at the different stages of the zoom.

The diagram below shows the signal at the input of the XE8805/05A, and at the output of the 1st, 2<sup>nd</sup> and 3<sup>rd</sup> amplifier.

**Figure 4. Intermediate Analog Chain Stage**

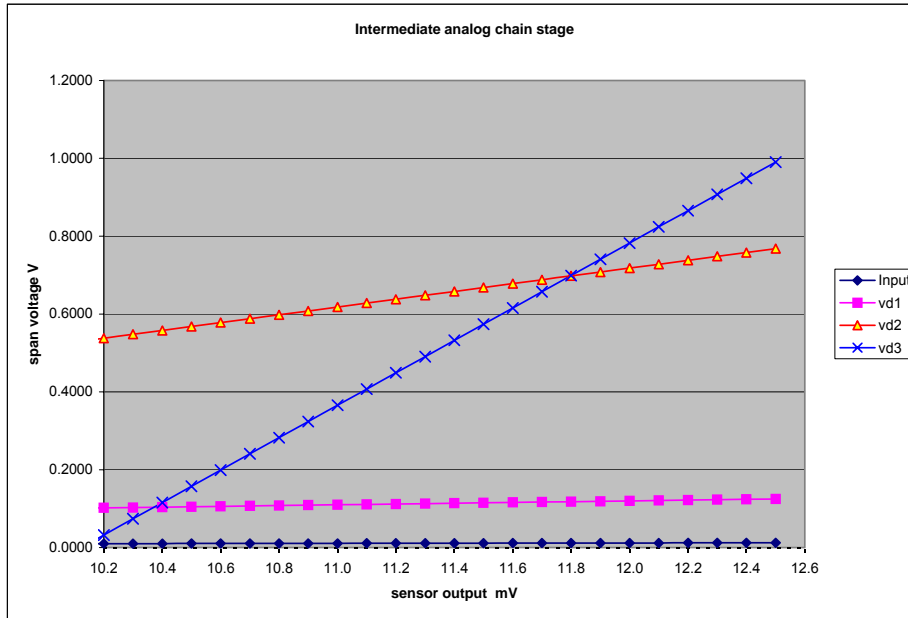

The signal is amplified to have a span voltage of 1.0 V at the input of the A/D converter, whereas the sensor signal is within 10 to 12.5 mV.

The tables below show the calculated parameters that represent the response above.

Values are in decimals.

Parameter	Value
Vref	2.41
Gain 1	10
Offset2	1
Gain2	10
Offset3	11
Gain3	50

**Table 2**

Pressure mBar	V <sub>in</sub> V	V <sub>d1</sub> V	V <sub>d2</sub> V	V <sub>d3</sub> V	ADC code
1050	0.0126	0.126	0.778	1.032	28065
1000	0.0120	0.120	0.718	0.782	21269
950	0.0114	0.114	0.658	0.532	14474
900	0.0108	0.108	0.598	0.282	7678
850	0.0102	0.102	0.538	0.032	883

Table 3

The values of the registers give the correct range of the span voltage. To convert the ADC code to an exact pressure value, the RISC core capabilities provide the developer with optimal flexibility

The formula below gives the equation to compute the correct value of the pressure:

$$P_{out} = \frac{P_{high} - P_{low}}{code_{high} - code_{low}} \cdot ADC\_code + code_{null} = \frac{1050 - 850}{28065 - 883} \cdot ADC\_code + 844$$

Code<sub>null</sub> is the equivalent pressure value corresponding to a null ADC code

### LCD display interface

The LCD display module uses a standard protocol. We have a choice between a 4 lines serial protocol and 8 lines parallel protocol. For this application we chose the 8 lines parallel protocol.

To interface the LCD display we used the two parallel ports of XE8805/05A. In this case, we used the PortC to transfer the 8 bits of data, and the PortB to transfer the 3 bits of control.

Figure 5. Connections between LCD Display and the XE8805/05A Pro-Start

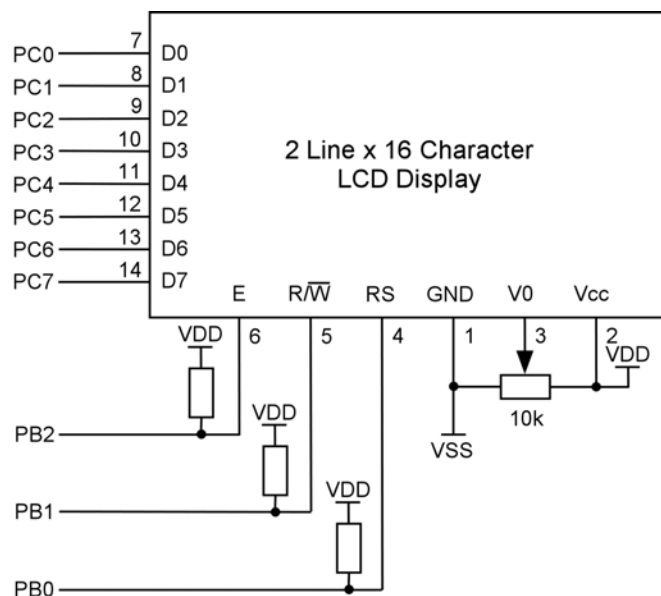

## Application program

### Flow chart

The following flow chart describes all program implementation.

### Main Routine

Figure 6

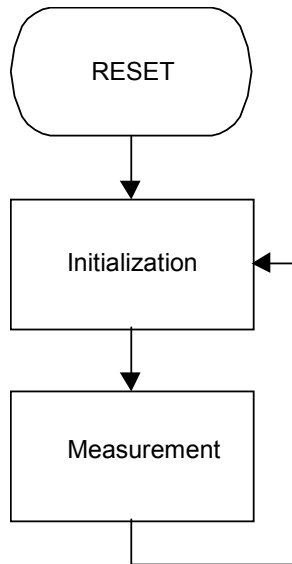

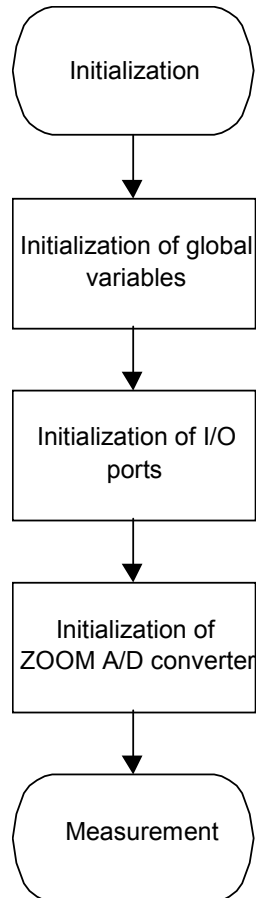
**Initialization routine****Figure 7**

Measurement routine  
Figure 8

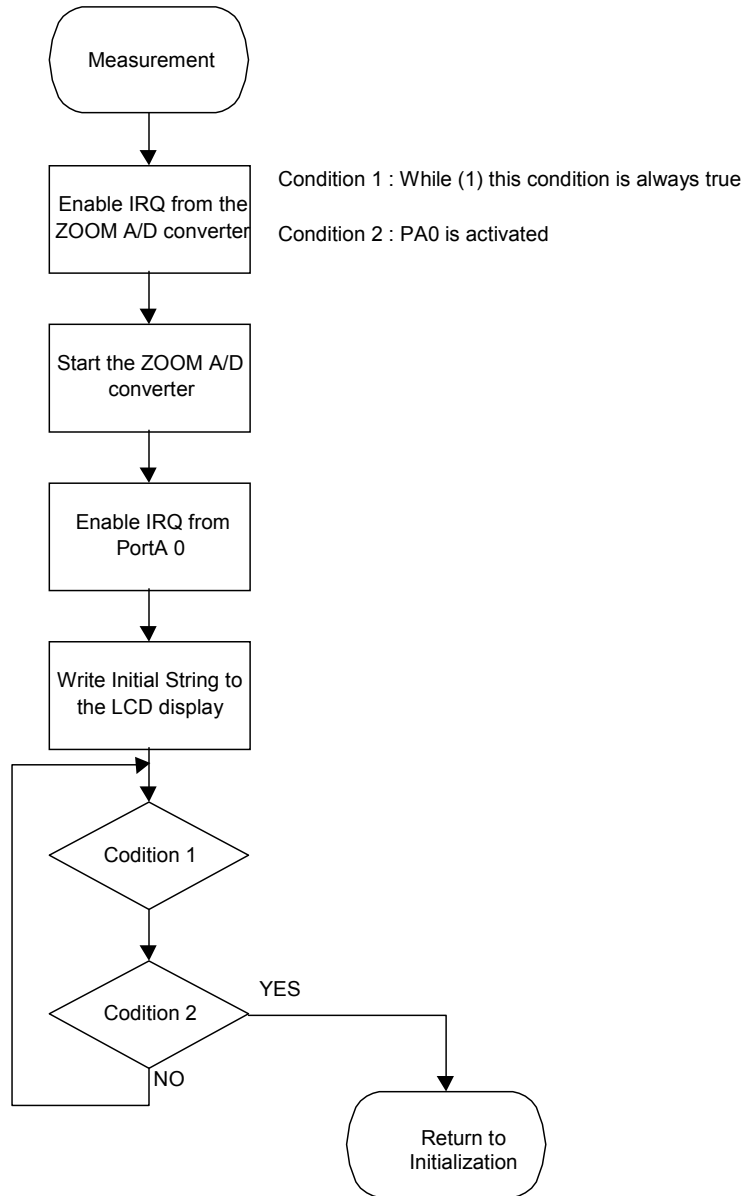

Zoom ADC Irq handler routine  
Figure 9

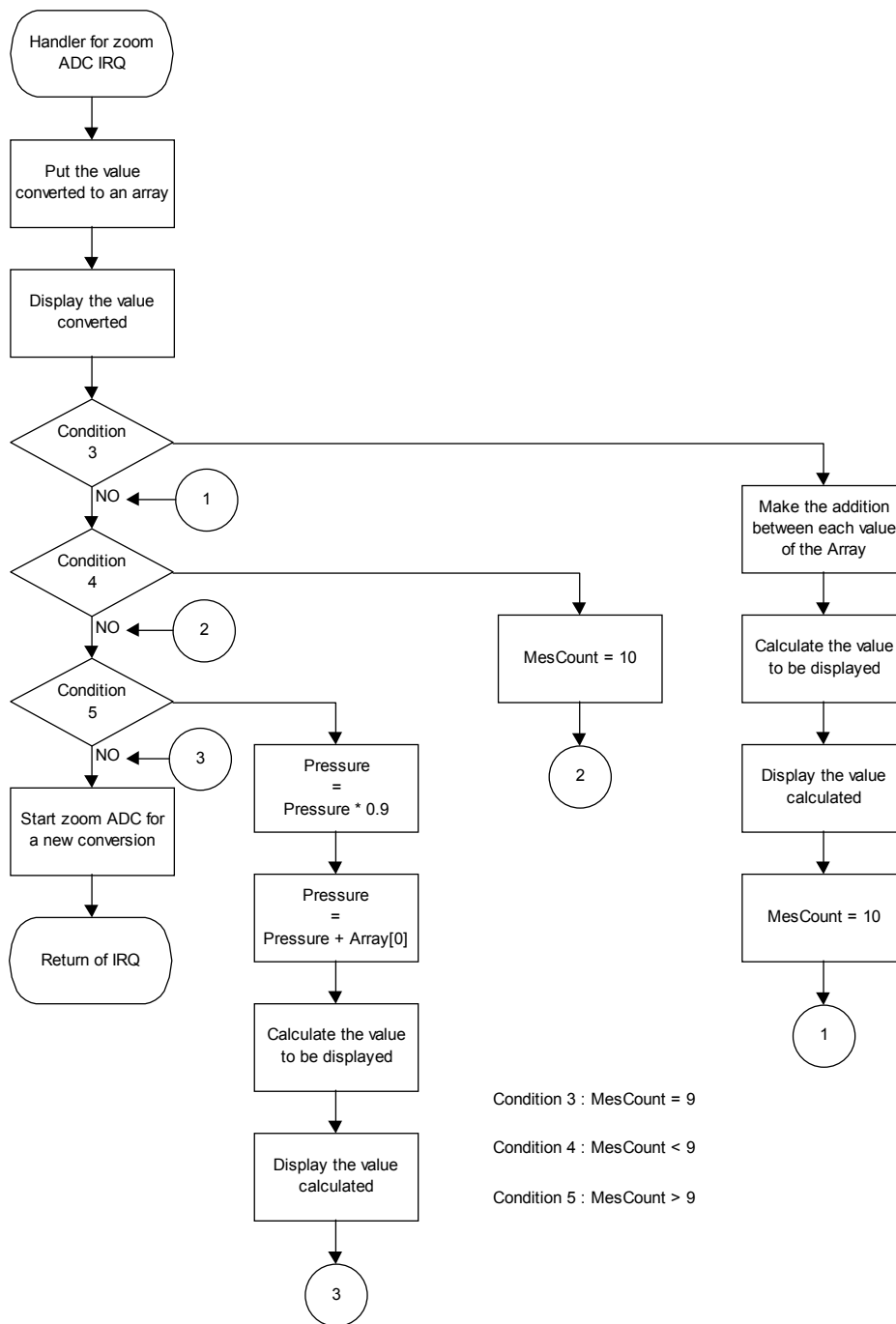

© Semtech 2006

All rights reserved. Reproduction in whole or in part is prohibited without the prior written consent of the copyright owner. The information presented in this document does not form part of any quotation or contract, is believed to be accurate and reliable and may be changed without notice. No liability will be accepted by the publisher for any consequence of its use. Publication thereof does not convey nor imply any license under patent or other industrial or intellectual property rights. Semtech. assumes no responsibility or liability whatsoever for any failure or unexpected operation resulting from misuse, neglect improper installation, repair or improper handling or unusual physical or electrical stress including, but not limited to, exposure to parameters beyond the specified maximum ratings or operation outside the specified range.

SEMTECH PRODUCTS ARE NOT DESIGNED, INTENDED, AUTHORIZED OR WARRANTED TO BE SUITABLE FOR USE IN LIFE-SUPPORT APPLICATIONS, DEVICES OR SYSTEMS OR OTHER CRITICAL APPLICATIONS. INCLUSION OF SEMTECH PRODUCTS IN SUCH APPLICATIONS IS UNDERSTOOD TO BE UNDERTAKEN SOLELY AT THE CUSTOMER'S OWN RISK. Should a customer purchase or use Semtech products for any such unauthorized application, the customer shall indemnify and hold Semtech and its officers, employees, subsidiaries, affiliates, and distributors harmless against all claims, costs damages and attorney fees which could arise.

#### Contact Information

Semtech Corporation  
Wireless and Sensing Products Division  
200 Flynn Road, Camarillo, CA 93012  
Phone (805) 498-2111 Fax : (805) 498-3804