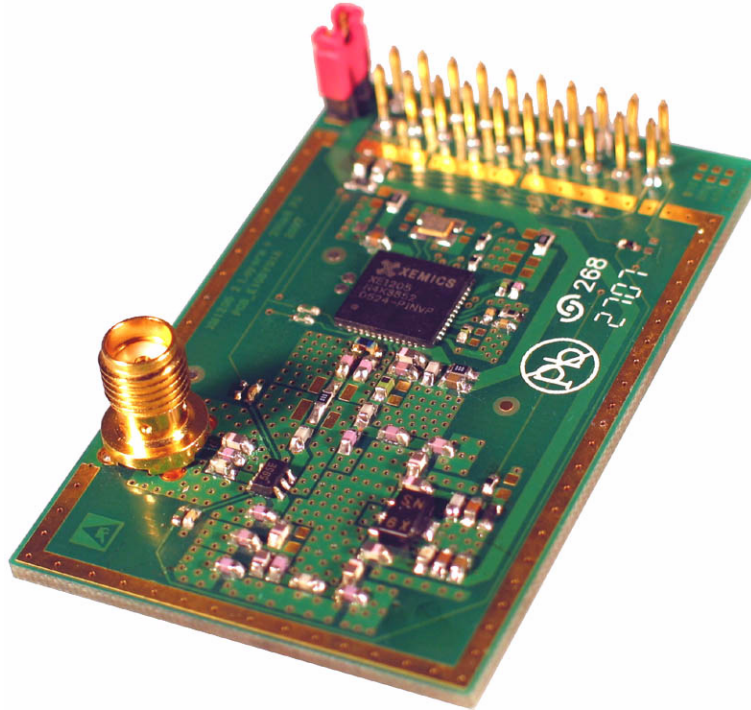

AN1205.04**250mW Power Amplifier Platform with the XE1205****GENERAL DESCRIPTION**

The XE1205 is an integrated transceiver operating in the 433, 868 and 915 MHz license-free ISM (Industrial, Scientific and Medical) frequency bands. This application note describes how to take advantage of a low-cost external Power Amplifier to reach an output power of up to 250 mW (+24dBm) at 915 MHz. A full bill of materials and details of regulatory compliance with §CFR 47 Part15.247 is also provided.

KEY PRODUCT FEATURES

- ◆ Programmable RF output power: from 12 to 24 dBm
- ◆ High Rx sensitivity: down to -121 dBm at 1.2 kbit/s, -116 dBm at 4.8 kbits
- ◆ Low power receive mode: 14 mA
- ◆ Good transmitter efficiency: 250 mA typ. @ +24 dBm
- ◆ 902 to 928 MHz frequency range
- ◆ Lowest-Cost Bill Of Materials: L-C based output filter

APPLICATIONS

- ◆ Long Distance Automatic Meter Reading
- ◆ Alarm system
- ◆ Asset tracking
- ◆ Long Range Telemetry

SUPPORT MATERIAL

- ◆ Schematic Drawing
- ◆ Bill Of Materials
- ◆ Gerber Files upon request

Please contact your Semtech representative.

Table of Contents

Section	Page
1. Board Description	3
1.1. Board Overview	3
1.2. Board Schematics	4
1.3. PCB Layout.....	5
1.4. Bill Of Materials.....	5
2. Board Performance.....	7
2.1. Output Power over the ISM Band	7
2.2. Pout vs. Vcc.....	7
2.3. Pout vs. Temperature	8
2.4. Spurious Emissions	9
3. Conclusion.....	10

Table of Figures

Figure 1. Board Overview	3
Figure 2. Schematic Diagram	4
Figure 3. PCB Top Layer	5
Figure 4. PCB Bottom Layer.....	5
Figure 5. Pout over Frequency	7
Figure 6. Output Power vs. Vcc.....	8
Figure 7. Power Consumption vs. Vcc	8
Figure 8. Spectral Purity DC-960 MHz	9
Figure 9. Spectral Purity 960 MHz - 10 GHz	10

1. Board Description

This 250 mW high power transceiver design is based on Semtech's XE1205 ISM band transceiver and an NEC NESG250134 SiGe RF transistor. Information about the NEC transistor can be found at the following websites:

www.ncsd.necel.com

www.cel.com

This high power Short Range Device design is implemented on a simple low-cost, two-layer FR4 substrate board. The design is as small as 37 x 57 mm, and is intended to meet the regulatory requirements of the North American FCC Part 15.247 FHSS (Frequency Hopping Spread Spectrum) systems.

1.1. Board Overview

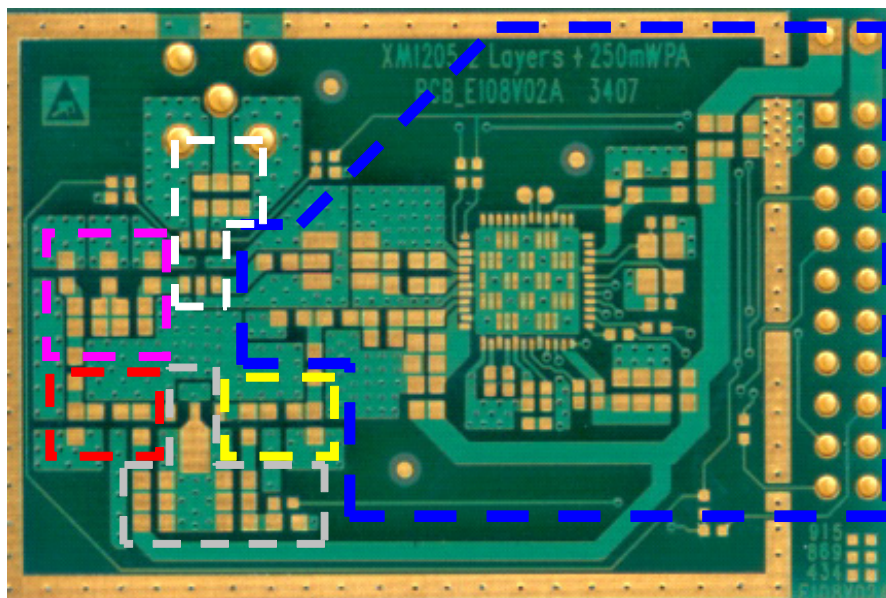

Figure 1. Board Overview

Figure 1 shows the reference design sub-divided into six different areas:

- ◆ XE1205 2-layer reference design (blue) - the output matching network of this stage has been modified to optimize power transfer to the following (PA) stage.
- ◆ Interstage Matching (yellow) - performs the impedance transformation between the XE1205 and the PA and is necessary to ensure stability.
- ◆ Power Amplifier (grey) - includes the PA (an NESG-250134) and its associated power supply biasing and decoupling.
- ◆ PA Output match (red) - necessary to ensure that the optimal gain, linearity and efficiency are achieved.
- ◆ Output Filter (purple) - required for harmonic rejection, to ensure regulatory compliance with §CFR 47 Part 15.247 of the FCC regulations. The filter is based upon discrete components for minimum cost.
- ◆ Antenna tank circuit and switch (white) - these components are taken from the original XE1205 reference design (downloadable from the Semtech website). However, a higher power switch (Hittite HMC595) has been used to accommodate the higher 250 mW output power.

1.3. PCB Layout

For low-cost and practicality, the reference design has been implemented on a 2-layer, 1.6mm-thick, FR4 substrate printed circuit board. The design can be implemented on other thicknesses and other substrate materials keeping in mind the following:

- ◆ Any change in board thickness or material will affect the impedance of the board, as will changes in track length or thickness. The RF signal path will be especially susceptible to such changes. We recommend, where possible, the design be kept as close as possible to the reference design.
- ◆ The application note **RF Design Guidelines: PCB Layout and Circuit Optimization** can be downloaded from the Semtech website www.semtech.com if the users want to implement the reference design for their own application.

Figure 3 and Figure 4 below show the two PCB layers, top and bottom sides.

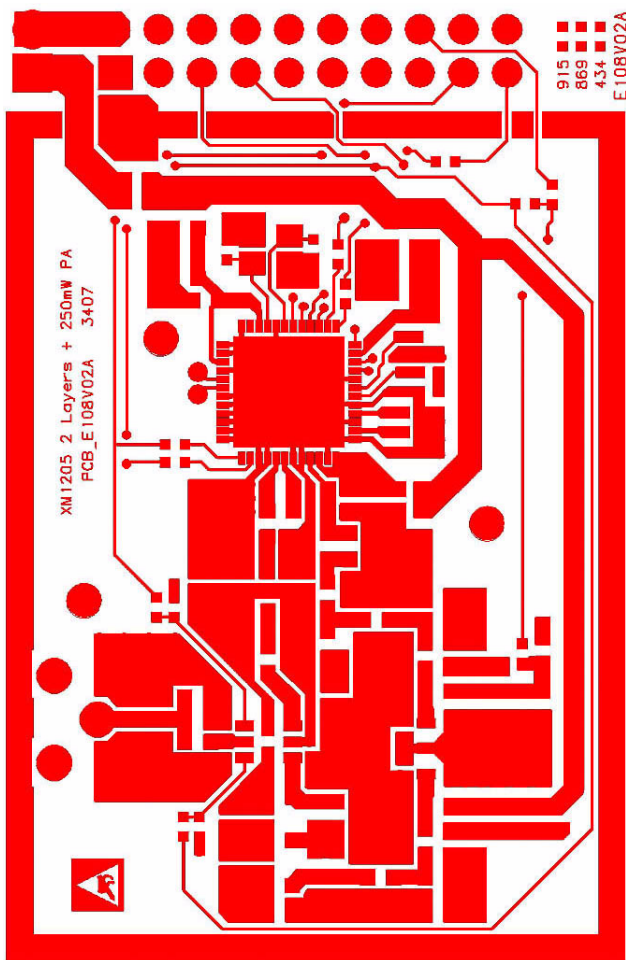

Figure 3. PCB Top Layer

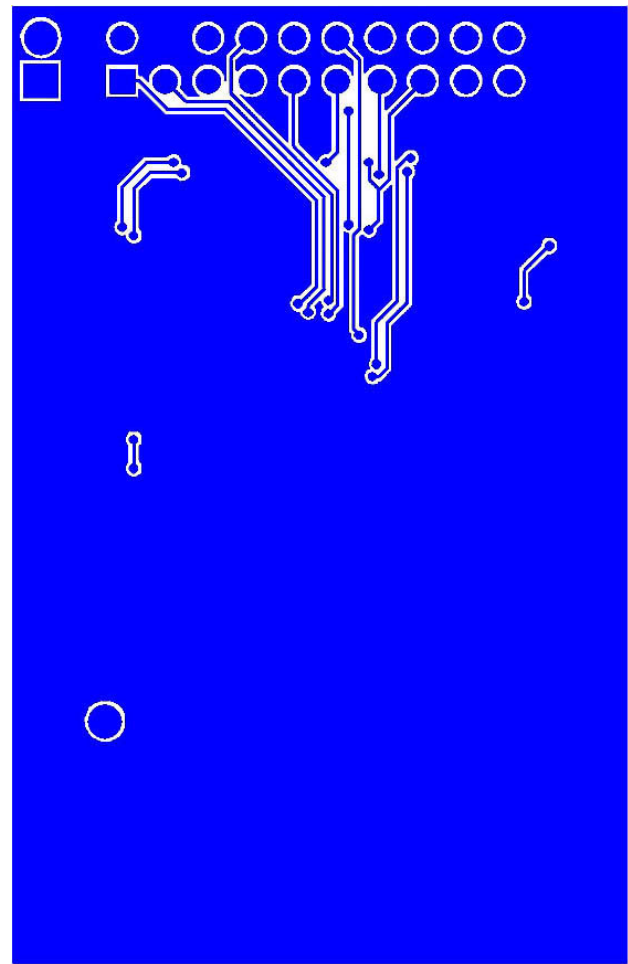

Figure 4. PCB Bottom Layer

1.4. Bill Of Materials

The table below gives the values and characteristics of the components detailed in the schematic on section 1.2. It is important to note that deviation from the specified components may result in a degradation of the circuit performances.

Table 1 Bill Of Materials at 915MHz

RefDes	MPN	Geom	Value	Qty	Description	Manufacturer
U1	XE1205I074TRLF	VQFN48	XE1205	1	RF transceiver IC	Semtech
U2	TMX S110	SMT 3.8x3.8	915MHz	1	SAW Bandpass Filter 915MHz	Temex
U3	HMC595E	SC-70 6L	HMC595	1	GaAs MMIC 3W T/R Switch	Hittite
Q1	NX3225DA 39MHz EXS00A-0255	SMD 3.2x2.5	39.0MHz	1	Crystal 39MHz CL=8pF	NDK
Q2	NESG250134	Power Minimold	NESG250134	1	NPN SiGe RF Transistor	NEC
D1		0603	1N4148	1	General purpose 1N4148 diode	
R1		0402	1k	1	Resistor (+/-5%)	
R2		0402	1k	1	Resistor (+/-5%)	
R3		0402	1k	1	Resistor (+/-5%)	
R4		0402	680	1	Resistor (+/-1%)	
R5		0402	1k	1	Resistor (+/-5%)	
R6		0402	1k	1	Resistor (+/-5%)	
R7			NC	0		
R8		0402	0R	1	Resistor	
R9		0402	0R	1	Resistor	
R10		0402	330	1	Resistor (+/-5%)	
R11		0402	0R	1	Resistor	
R434			NC	0		
R869			NC	0		
R915		0402	0R	1	Resistor	
C1		0603	33pF	1	Capacitor NPO (+/-5%)	
C2		0603	1uF	1	Capacitor Y5V (+80/-20%)	
C3		0603	1.8pF	1	Capacitor NPO (+/-0.25pF)	
C4		0603	1.2pF	1	Capacitor NPO (+/-0.25pF)	
C5		0603	1.2pF	1	Capacitor NPO (+/-0.25pF)	
C6			NC	0		
C7		0603	2.2pF	1	Capacitor NPO (+/-0.25pF)	
C8		0603	33pF	1	Capacitor NPO (+/-5%)	
C9			NC	0		
C10		0402	1.5pF	1	Capacitor NPO (+/-0.25pF)	
C11		0402	10nF	1	Capacitor X7R (+/-10%)	
C12		0402	1nF	1	Capacitor X7R (+/-10%)	
C13		0603	1.2pF	1	Capacitor NPO (+/-0.25pF)	
C14		0603	33pF	1	Capacitor NPO (+/-5%)	
C15		0402	1nF	1	Capacitor X7R (+/-10%)	
C16		0402	1nF	1	Capacitor X7R (+/-10%)	
C17			NC	0		
C18			NC	0		
C19			NC	0		
C20		0603	1.2pF	1	Capacitor NPO (+/-0.25pF)	
C21		0603	33pF	1	Capacitor NPO (+/-5%)	
C22		0603	1uF	1	Capacitor Y5V (+80/-20%)	
C23		0603	33pF	1	Capacitor NPO (+/-5%)	
C24		0603	68pF	1	Capacitor NPO (+/-5%)	
C25		0603	10nF	1	Capacitor X7R (+/-10%)	
C26			NC	0		
C27			NC	0		
C28		0603	3.3nF	1	Capacitor X7R (+/-10%)	
C29		0603	33pF	1	Capacitor NPO (+/-5%)	
C30		0603	10nF	1	Capacitor X7R (+/-10%)	
C32		0603	1uF	1	Capacitor Y5V (+80/-20%)	
C33		0603	1.8pF	1	Capacitor NPO (+/-0.25pF)	
C34		0603	3.9pF	1	Capacitor NPO (+/-0.25pF)	
C35		0603	33pF	1	Capacitor NPO (+/-5%)	
C36		0603	0.47pF	1	Capacitor NPO (+/-0.25pF)	
C37		0603	2.2pF	1	Capacitor NPO (+/-0.25pF)	
C38			NC	0		
C39		0603	2.2pF	1	Capacitor NPO (+/-0.25pF)	
C40		0603	2.2pF	1	Capacitor NPO (+/-0.25pF)	
C41		0402	Note 1	1	Capacitor NPO (+/-0.25pF)	
C42		0402	Note 1	1	Capacitor NPO (+/-0.25pF)	
L1		0603	10nH	1	Multilayer inductor	
L2		0603	47nH	1	Multilayer inductor	
L3	LQW18AN27NG00D	0603	27nH	1	Wirewound	MURATA
L4		0402	5.6nH	1	Multilayer inductor	
L5		0402	18nH	1	Multilayer inductor	
L6		0603	18nH	1	Multilayer inductor	
L7		0603	3.3nH	1	Multilayer inductor	
L8		0603	0R	1	Resistor	
L9		0603	47nH	1	Multilayer inductor	
L10		0603	0R	1	Resistor	
L11		0603	0R	1	Resistor	
L12		0603	0R	1	Resistor	
L13		0603	47nH	1	Multilayer inductor	
L15		0603	3.3nH	1	Multilayer inductor	
L16		0603	6.8nH	1	Multilayer inductor	
L17		0603	2.7nH	1	Multilayer inductor	
RF_IO		SMA	50 Ohms	1	SMA Straight Jack Receptacle for PCB mount	

Note 1: C41 and C42 are adjusted to tune LO at nominal frequency of 915.000MHz

2. Board Performance

This application was designed to meet the conducted output power requirement of 250 mW (i.e. +24 dBm) over the 902-928 MHz North American ISM band. This circuit will deliver the specified power over the following ranges:

- ◆ Pout=+24 dBm
- ◆ Vcc range from 2.4 to 3.6 V
- ◆ Temperature range from -40 to +85°C
- ◆ Output Power derating along all operating conditions: +/-2 dB

2.1. Output Power over the ISM Band

Figure 5 shows the variation in output power of the XE1205 power amplifier circuit over the 902 to 928 MHz ISM band. The measured performance guarantees a constant link budget over the whole band of operation.

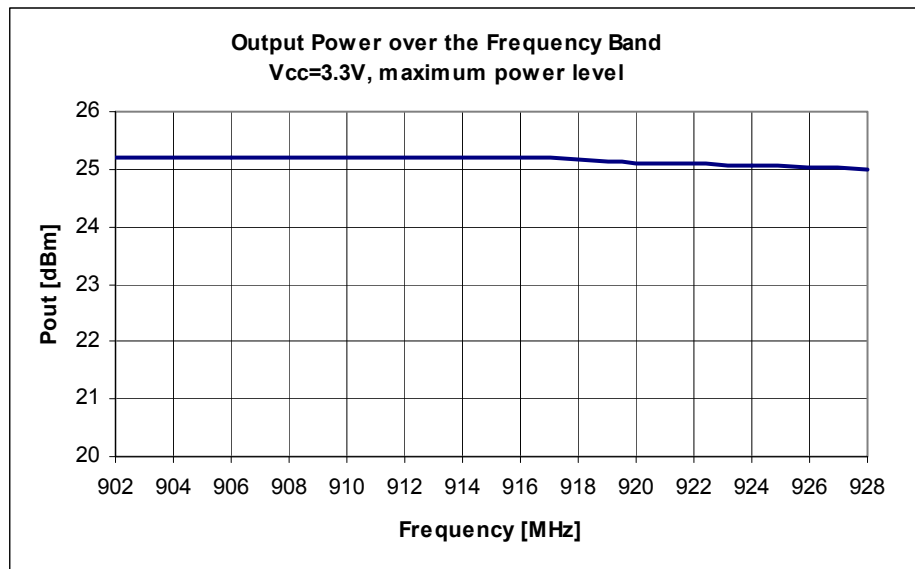

Figure 5. Pout over Frequency

2.2. Pout vs. Vcc

Figure 6 below illustrates the reference design performance versus the supply voltage range for each of the output power settings of XE1205. Figure 7 then shows the total dissipation of the amplifier plus XE1205 over the same range of test conditions.

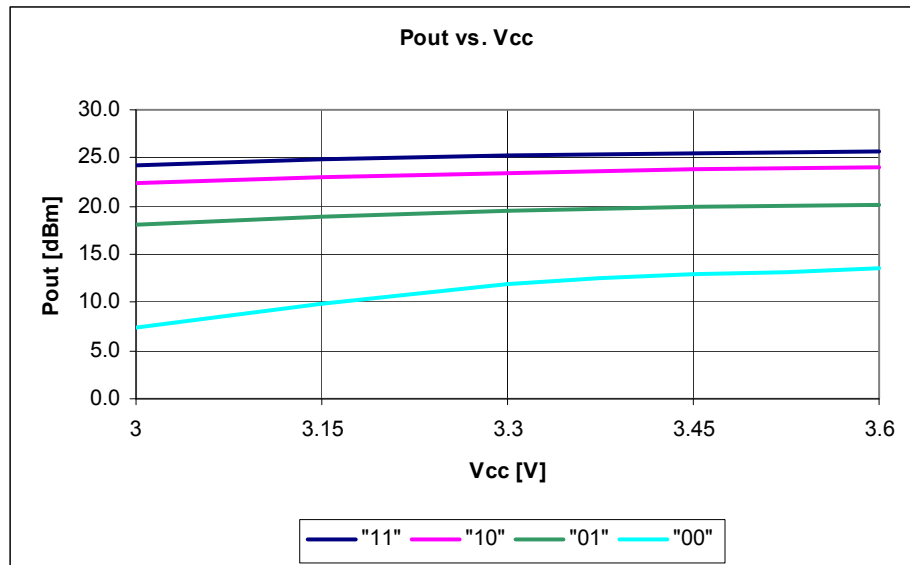

Figure 6. Output Power vs. Vcc

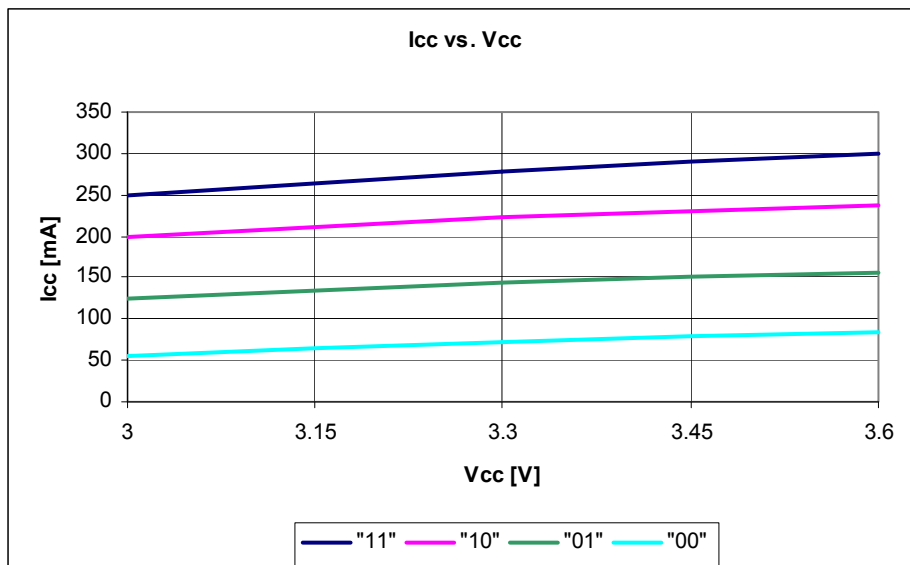

Figure 7. Power Consumption vs. Vcc

2.3. Pout vs. Temperature

With the combination of D1 and R10, the design exhibits a very good stability of the output power over the temperature range, i.e. from -40 to +85°C:

- ◆ at 25°C, 3.3V: +25.2 dBm
- ◆ at -40°C, 3.3V: +25.8 dBm
- ◆ at +85°C, 3.3V: +23.7 dBm

2.4. Spurious Emissions

The North American regulatory constraints applicable to this circuit are given in the FCC Part 15.247 section.

- ◆ If the spurious emissions fall inside the restricted bands (listed under section 15.205a), their level should be below 200 microvolts per meter measured at a 3 meter distance, if their frequency is below 960 MHz.
- ◆ Spurious emissions that fall inside restricted bands over 960 MHz should respect a field strength limit of 500 microvolts per meter at a 3 meter distance.
- ◆ For any other spuri, their level should be 20 dB below that of the carrier (i.e. -20dBc).

The measured radiated response will, of course, depend upon the type of antenna employed and the screening employed. Here, an equivalent conducted measurement is performed to assess compliance with the FCC limits. We define these limits as:

- ◆ 200 uV/m @ 3m correspond to -49.2 dBm EIRP limit below 960 MHz
- ◆ 500 uV/m @ 3m correspond to -41.2 dBm EIRP limit above 960 MHz

These limits are shown in red on Figure 8 and Figure 9, assuming the use of a 0 dBi gain antenna.

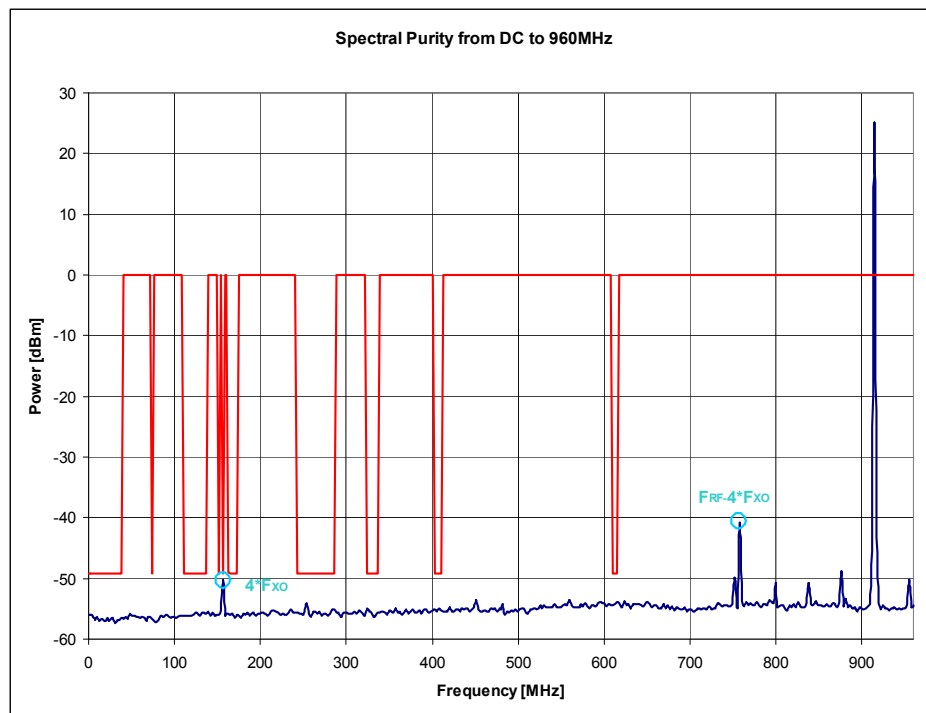

Figure 8. Spectral Purity DC-960 MHz

A spurious emission at 4 times the crystal oscillator frequency (i.e. 156 MHz +/- 100ppm typ.) is highlighted on Figure 8. Referring to the FCC Part 15.205(a), which lists the restricted bands of operation, the 200uV/m @ 3 meters limit will apply from 156.52475 to 156.52525 MHz. This is very narrow and, since the crystal drift is not expected to be over +/-100ppm, this spur will not fall inside the restricted band.

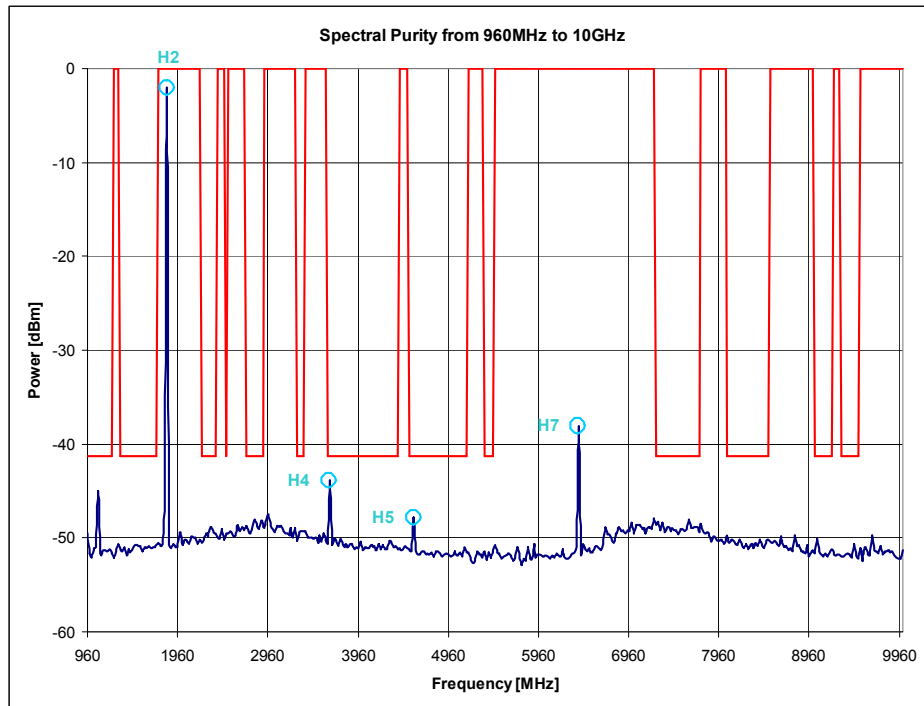

Figure 9. Spectral Purity 960 MHz - 10 GHz

The harmonic frequencies of the transmitter are highlighted on Figure 9. Their level is below the specified limit.

Notes:

- ◆ Semtech suggests the user also read the accompanying application note: **FCC Regulations for ISM Band Devices: 902-928 MHz**. This describes in detail the North American FCC restriction on ISM band Short Range Devices. It can be downloaded from www.semtech.com
- ◆ The rejection of harmonic frequencies on this design, has been achieved through lumped elements, to enable the lowest-cost BOM. For size constrained applications, the filter (outlined in purple on Figure 1) can be replaced by a multilayer LTCC (Low Temperature Co-Fired Ceramic) low-pass filter. This type of filter exhibits a very good harmonic response within a single 0603 footprint. An example is the *0915LP15B026* from Johanson Technology. It offers a minimum attenuation of 30 dB on the 2nd and 3rd harmonics (actually more than 40dB). Additional information can be found at www.johansontechnology.com.

3. Conclusion

A reference design for a single-stage 250 mW power amplifier in conjunction with XE1205 has been presented. This reference design uses a low-cost lumped element filter and is intended for operation in the 902-928 MHz ISM band. Applications of this circuit include, for instance, long range Automatic Meter Reading or two-way car alarm systems.

© Semtech 2008

All rights reserved. Reproduction in whole or in part is prohibited without the prior written consent of the copyright owner. The information presented in this document does not form part of any quotation or contract, is believed to be accurate and reliable and may be changed without notice. No liability will be accepted by the publisher for any consequence of its use. Publication thereof does not convey nor imply any license under patent or other industrial or intellectual property rights. Semtech assumes no responsibility or liability whatsoever for any failure or unexpected operation resulting from misuse, neglect improper installation, repair or improper handling or unusual physical or electrical stress including, but not limited to, exposure to parameters beyond the specified maximum ratings or operation outside the specified range.

SEMTECH PRODUCTS ARE NOT DESIGNED, INTENDED, AUTHORIZED OR WARRANTED TO BE SUITABLE FOR USE IN LIFE-SUPPORT APPLICATIONS, DEVICES OR SYSTEMS OR OTHER CRITICAL APPLICATIONS. INCLUSION OF SEMTECH PRODUCTS IN SUCH APPLICATIONS IS UNDERSTOOD TO BE UNDERTAKEN SOLELY AT THE CUSTOMER'S OWN RISK. Should a customer purchase or use Semtech products for any such unauthorized application, the customer shall indemnify and hold Semtech and its officers, employees, subsidiaries, affiliates, and distributors harmless against all claims, costs damages and attorney fees which could arise.

Contact information

Semtech Corporation Advanced Communications & Sensing Products

E-mail: sales@semtech.com acsupport@semtech.com
Internet: <http://www.semtech.com>

USA 200 Flynn Road, Camarillo, CA 93012-8790.
Tel: +1 805 498 2111 Fax: +1 805 498 3804

FAR EAST 12F, No. 89 Sec. 5, Nanking E. Road, Taipei, 105, TWN, R.O.C.
Tel: +886 2 2748 3380 Fax: +886 2 2748 3390

EUROPE Semtech Ltd., Units 2 & 3, Park Court, Premier Way, Abbey Park Industrial Estate, Romsey, Hampshire, SO51 9DN.
Tel: +44 (0)1794 527 600 Fax: +44 (0)1794 527 601



ISO9001
CERTIFIED