

AN1200.03 Application Note

Frequency Hopping

Table of Contents

1	Introduction	3
2	Spread Spectrum Systems	3
3	FCC Specifications.....	3
4	Protocol: Synchronization and Communication.....	3
4.1	Synchronization	3
4.1.1	Timing and frequency behavior	4
4.1.2	Flowchart	5
4.1.3	Timing optimization.....	6
4.2	Communication phase.....	7
4.2.1	Timing and frequency behavior	8
4.2.2	Flowchart	9
5	Hardware Implementation.....	11
6	Software Implementation	11
6.1	Initialisation.c	13
6.2	XE1205DriverMSP430.c.....	13
6.3	FreqHopping.c	14

1 INTRODUCTION

This application note is designed to enable you to develop a frequency hopping system using an XE1205 on both the transmit and the receive part. The XE1205 is the ideal transceiver for wide band and narrow band communications. The 15-Byte FIFO is also ideal to gain CPU resources. This application is developed under the MSP430 with an 8MHz CPU clock.

2 SPREAD SPECTRUM SYSTEMS

In spread spectrum systems, the signal energy is spread over a wider frequency range. These systems have the advantages of being less sensitive to interference and of being harder to be detected. In the ISM bands, it is often used in the US band 902-928 MHz, where there is a lot of interference. Moreover, using spread spectrum techniques allows one to transmit power up to 1W under FCC regulations. The Frequency hopping system is a spread spectrum system. FCC specifications for frequency hopping systems are detailed below.

3 FCC SPECIFICATIONS

According to the FCC regulations section 15.247, it is discriminated channels having a 20 dB bandwidth lower than 250 kHz and between 250 – 500 kHz.

For channels lower than 250 kHz, the system must use at least 50 hopping frequencies within a period of 20 sec. So the minimum hopping frequency is 2.5 Hz.

For channels having a 20 dB bandwidth between 250 – 500 kHz, the system must use at least 25 hopping frequencies within a period of 10 sec.

In the two cases, the system shall hop following a pseudo random order. The maximum output power is 1 Watt for systems using at least 50 hopping channels and 0.25 Watt for systems using less than 50 hopping channels.

4 PROTOCOL: SYNCHRONIZATION AND COMMUNICATION

In Frequency hopping systems, there are mainly two phases. First, transmitter and receiver must become synchronized. Then, they must hop and communicate together. During the communication phase, many cases must be considered, for example if some packets or the communication is lost. This application note will explain the way synchronization and communication phase are implemented.

4.1 SYNCHRONIZATION

During the synchronization phase, the receiver waits on a channel and the transmitter hops to predefined channels. It always sends the same data "SYNC" phase and when the transmitter and the receiver are on the same channel and that the receiver recognizes this data, it then sends an "ACK" to the transmitter. They are then synchronized and can go into communication phase.

During the communication phase, the hopping time is defined by the variable TIME_HOP and adjusted to a clock of 125 KHz. So to program a hopping time of 80 ms, $TIME_HOP = 80 * 125 = 10000$.

During the synchronization phase and to reduce it, the transmitter hops quickly than during the communication phase. The hopping time is $Hopping\ Time = TIME_HOP / FACTORSYNC$.

4.1.1 Timing and frequency behavior

Bellow is illustrated the transmitter and the receiver behavior (channel vs time) during the synchronization phase :

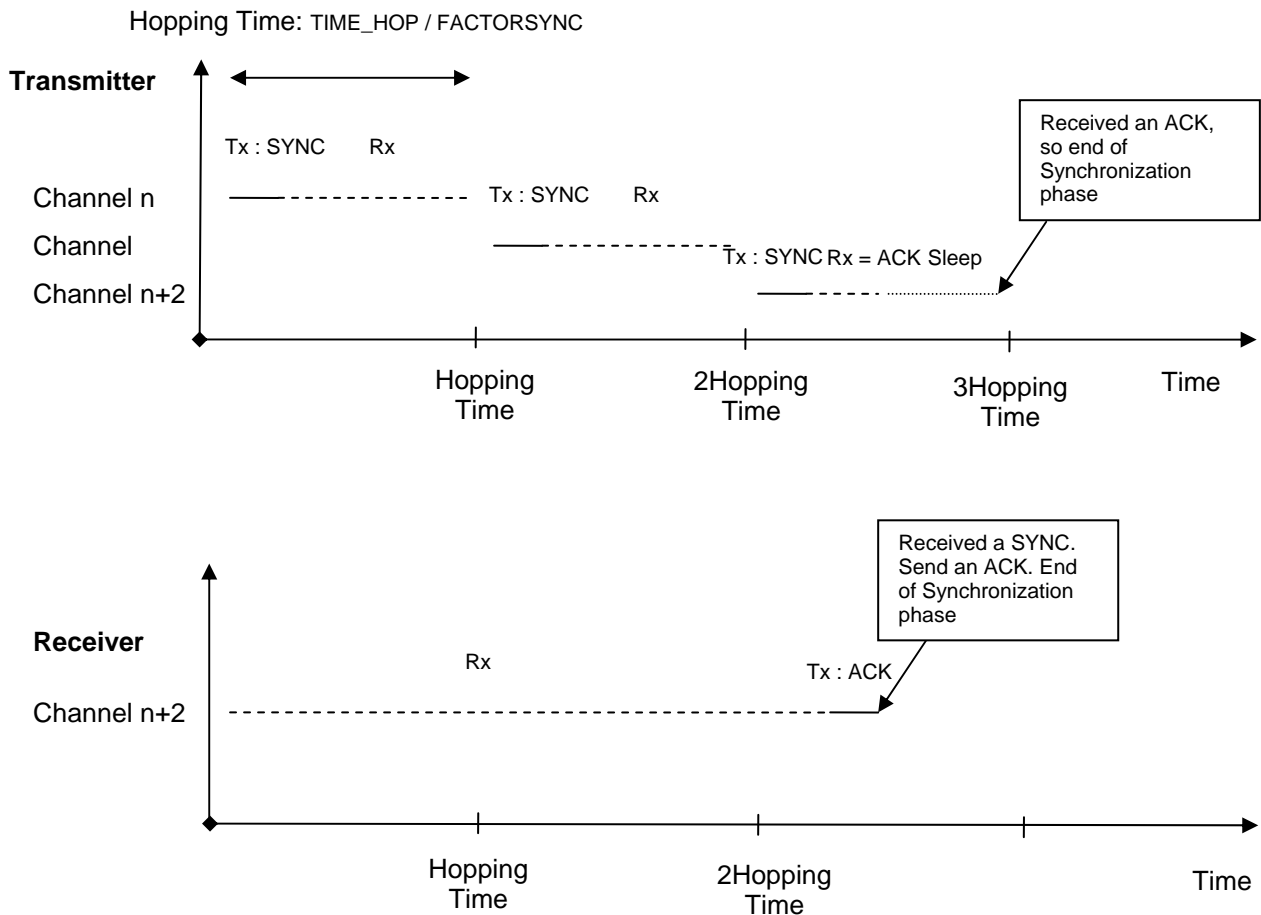

4.1.2 Flowchart

Synchronization for the transmitter:

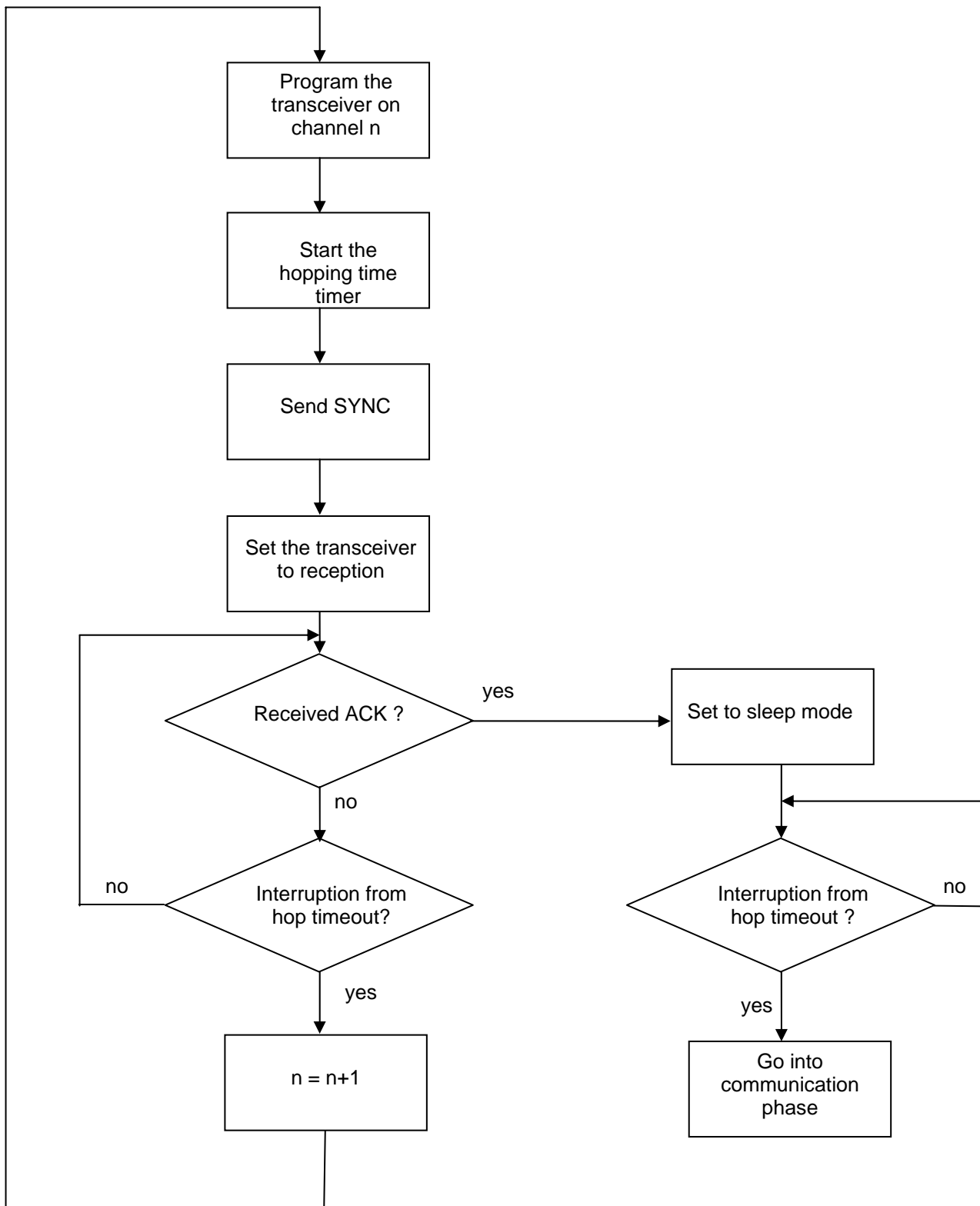

Synchronization for the receiver:

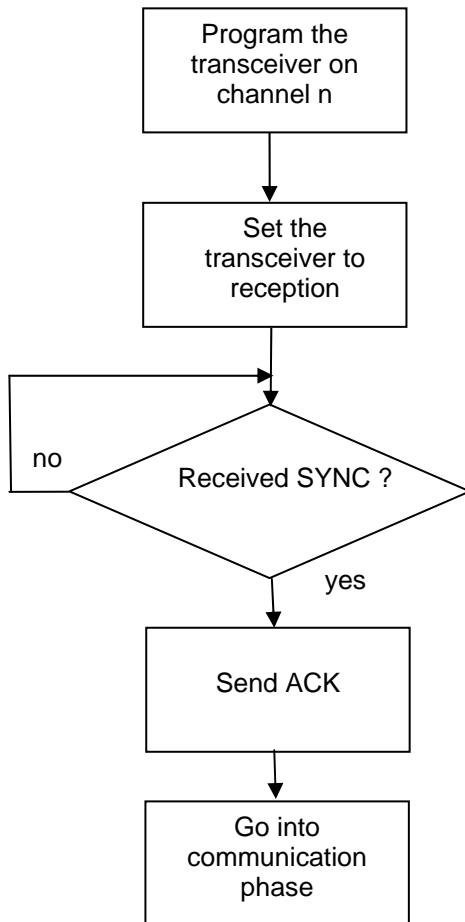

4.1.3 Timing optimization

The maximum time to get synchronized is a function of the number of channels (NBCHANNEL), the communication hopping time (TIME_HOP) and the factor (FACTORSYNC) used to decrease the synchronization phase. So

$$T_{SyncMax} = \frac{NBCHANNEL * HoppingTime}{ClkTimer} = NBCHANNEL * \frac{TIME_HOP}{ClkTimer * FACTORSYNC}$$

For NBCHANNEL = 50, TIME_HOP = 10000, FACTORSYNC= 16 and ClkTimer = 125 then $T_{syncmax} = 250$ ms.

The hopping time during the synchronization should be greater than the time needed to send the frame SYNC and ACK. This timing is obviously a function of the Bit rate. For a Bite rate of 76.8 kbit/s, it takes 1.35 ms to send the four ascii byte "SYNC" and 1.25 ms to send "ACK" according to the frame structure (32 bits of preamble, 32 bits of pattern, 8 bits of the data size and the data). We must also take into account the time it takes to go from transmitter to receiver mode and the code execution. We can estimate it at about 800 us. So we can consider that the minimum hopping time is : $1.35 + 0.8 + 0.8 + 1.25 = 4.2$ ms. For TIME_HOP = 10000, FACTORSYNC = 16 and ClkTimer = 125, the hopping time is 5 ms. It is then a quite good optimization.

The parameters NBCHANNEL, TIME_HOP and FACTORSYNC are located in the file FreqHopping.h. The channels are defined in the table FreqTable[] in the file FreqHopping.c.

4.2 COMMUNICATION PHASE

After the synchronization phase, the transmitter and the receiver enter into the communication phase. At the beginning of this phase, the transmitter and the receiver hop to the next channel. Then the receiver is set in receive mode and the transmitter sends the data. When the data is received correctly the receiver sends an ACK to the transmitter. The receiver then hops to the next channel while the transmitter goes into sleep mode and waits until the end of the hopping time to hop to the next channel. We then ensure that the hopping time is well conserved independently to the length of the burst of data. In this configuration, we also ensure that the receiver is in reception before the transmitter sends its data. The transmitter and receiver hop to the next channel as defined in the table FreqTable [], they don't hop in a pseudo-random way.

During this communication phase, the transmitter hops, transmits data and waits for an acknowledgement. If it doesn't receive the ACK, either it hops to the next channel and transmits the same data or it goes back into synchronization. It goes back into synchronization if it has already lost more than MAXLOSSACK acknowledgment.

During the communication phase, the receiver hops, wait on a data channel until the Rx timeout. This timeout is $2 * \text{TIME_HOP}$. If it didn't receive good data, either it hops to the next channel + 1 regarding the timeout or if it has lost more than MAXRXLOSSBURST burst, it goes back into synchronization phase.

The length of a burst of data is defined by the variable NBDATABYTEBURST. It determines the number of byte send in a burst. The parameters MAXLOSSACK, MAXRXLOSSBURST and NBDATABYTEBURST are located in the file FreqHopping.h.

In the frame structure, you could introduce an ID field to check the packet ID received. In case the transmitter don't receive an acknowledgement and retransmit the same data, the receiver could compare the packet ID received with the previous packet ID. It could then decide to add it or not to the previous frame to construct the complete data buffer.

4.2.1 Timing and frequency behavior

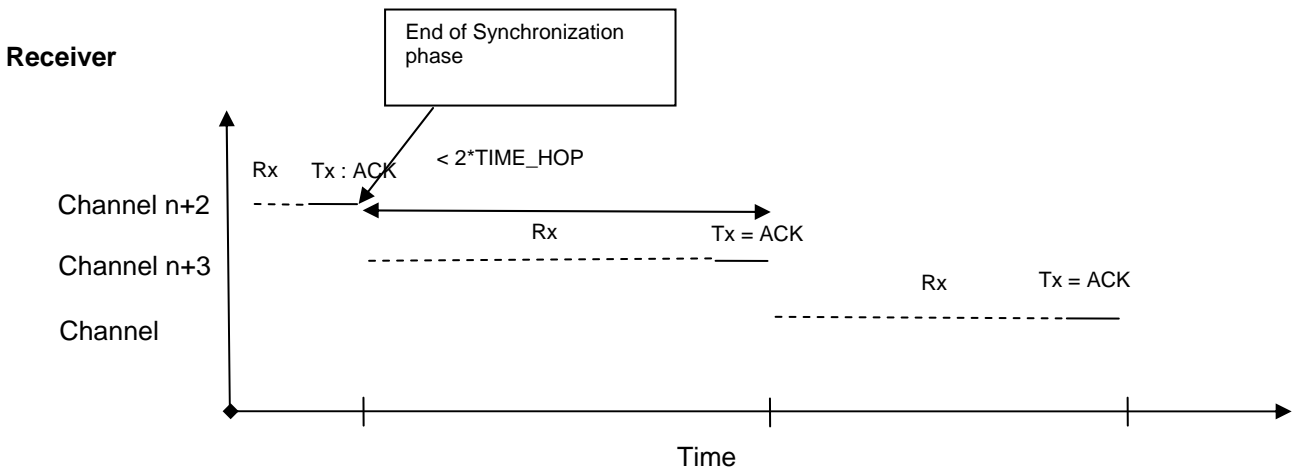
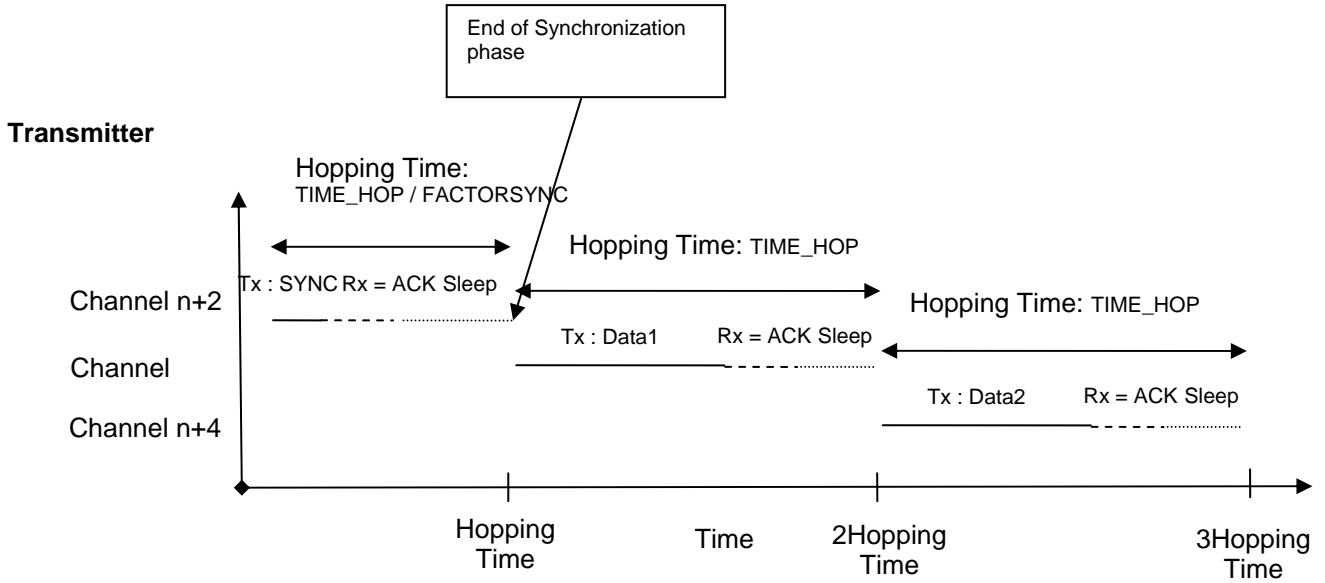

4.2.2 Flowchart

Communication phase for the transmitter

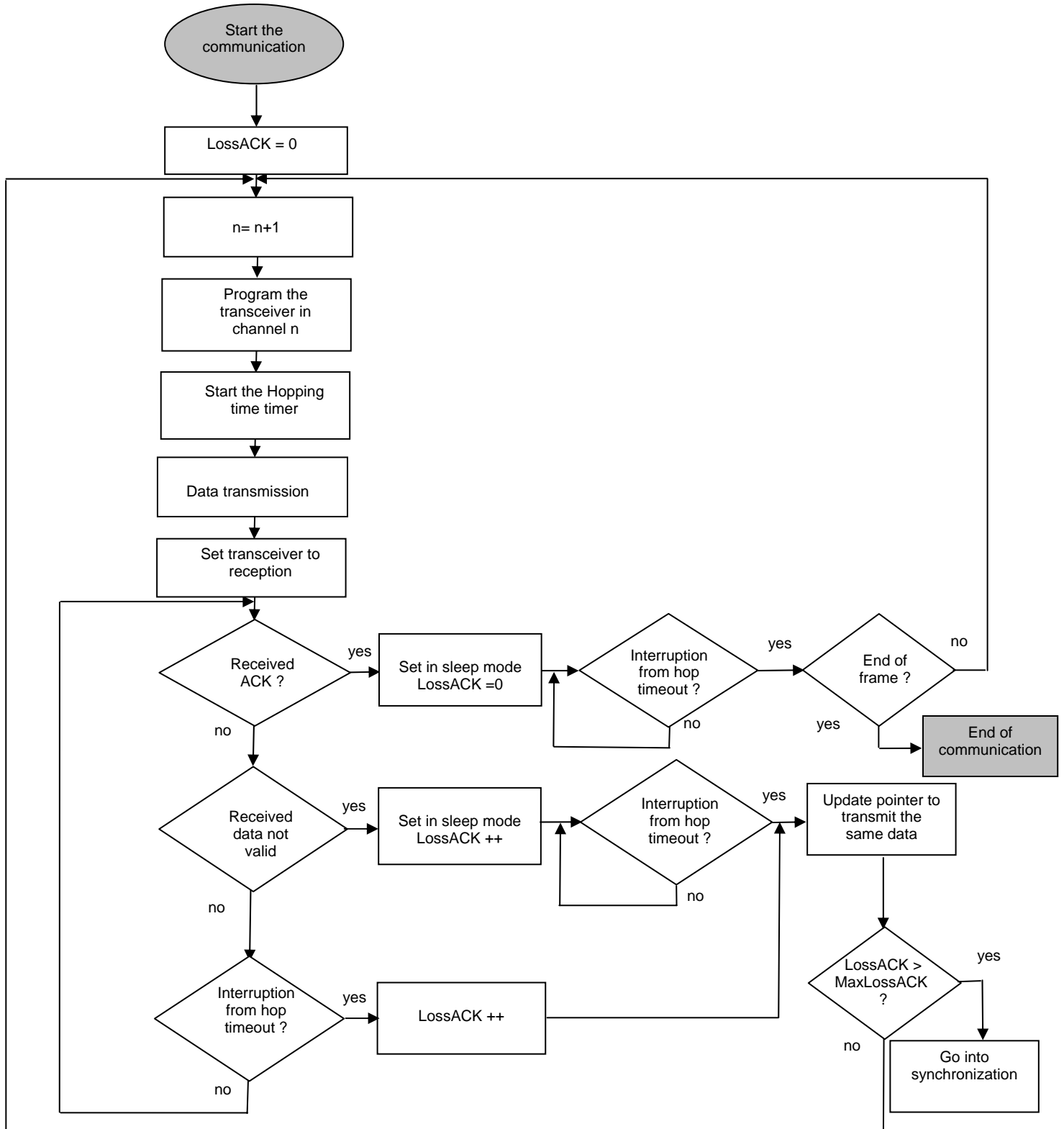

Communication phase for the receiver:

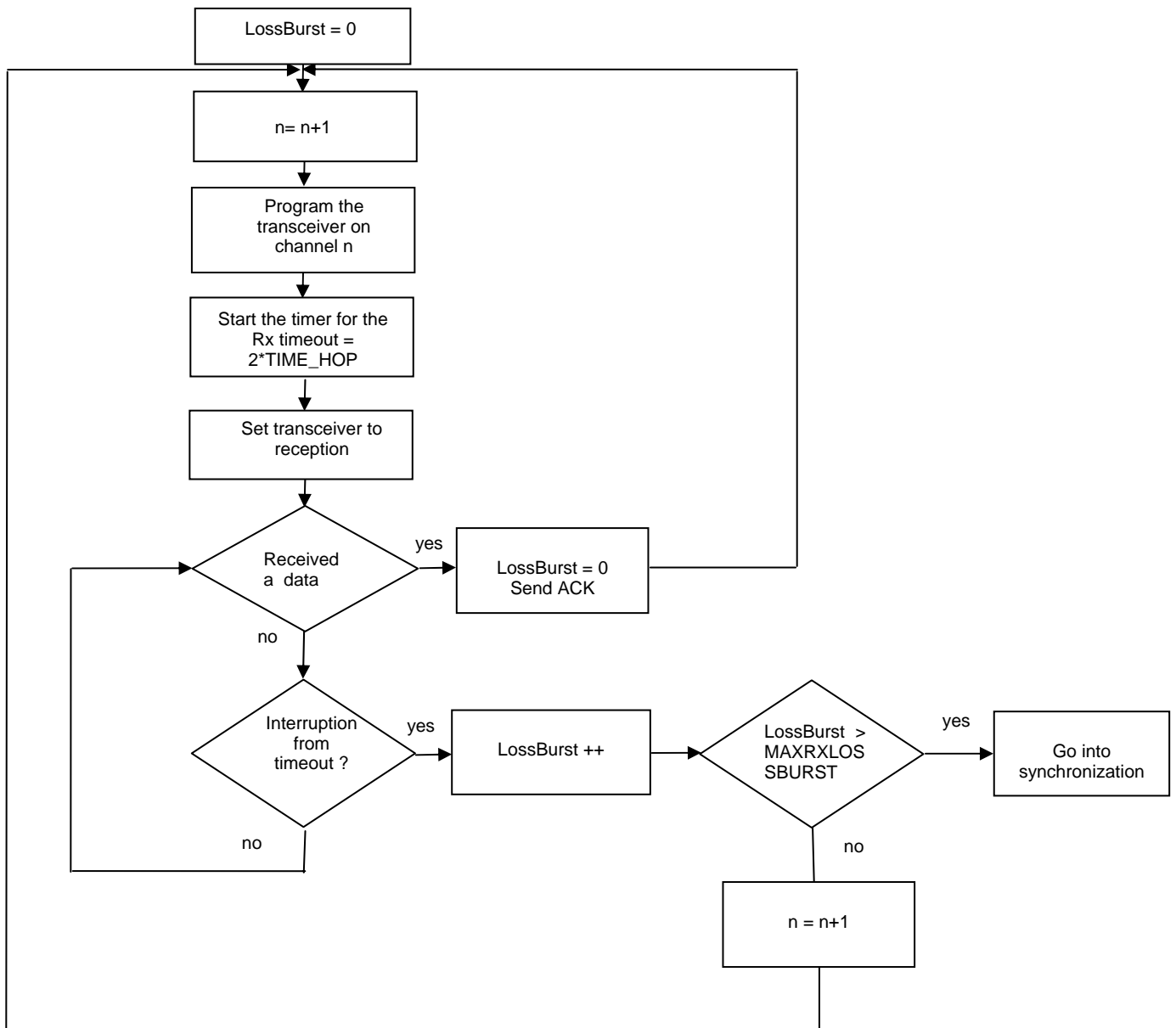

5 HARDWARE IMPLEMENTATION

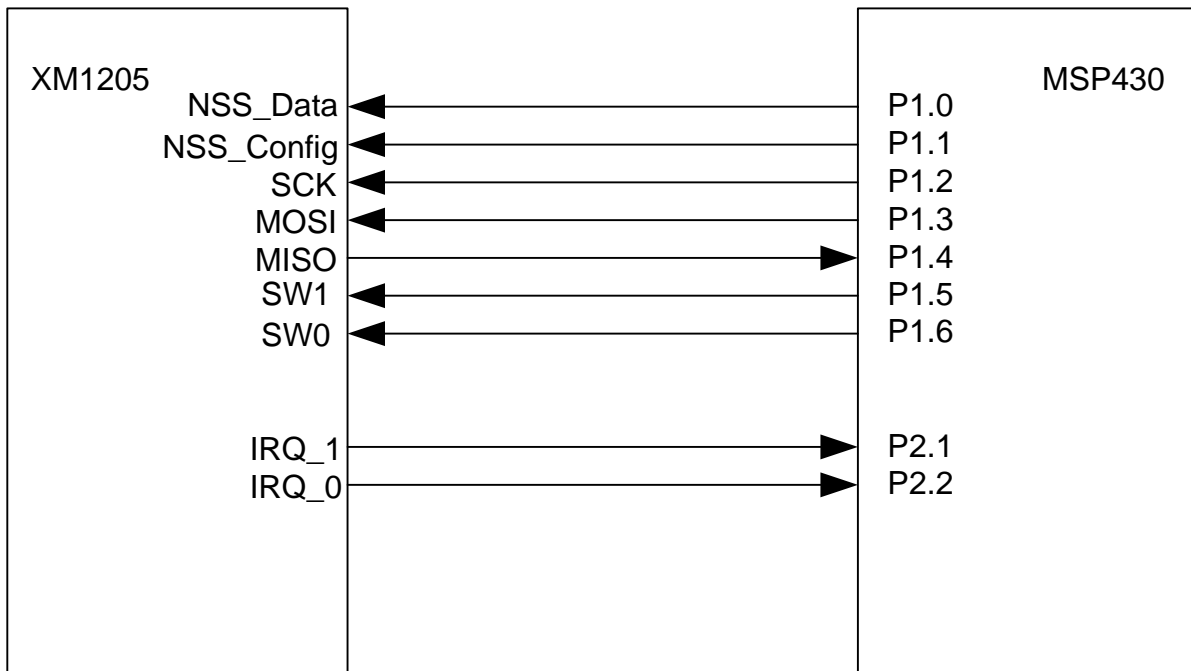

6 SOFTWARE IMPLEMENTATION

The main function calls functions that first initialize the microcontroller `InitMicro()`; and the RF Chip `InitRFChip()`;

When programming the transmitter, the `EnableTransceiver` variable must be set to true and false when programming the receiver.

As a demonstration of this frequency hopping application, the main function is developed as followed:

In a loop, the transmitter and the receiver are set in synchronization phase. When they are synchronized, the transmitter enters into communication phase. Then, during a burst, the transmitter sends one byte. The receiver shows the received byte on the port 4. The data sent are defined in the buffer `RFbuffer`. They communicate following the flowchart indicated in paragraph 4.2.2. When the complete buffer is sent, they then go back into synchronization phase. The same buffer is then sent and the received data shown on port 4 following a loop.

During a burst, the length of the data sent is limited to one byte. But it is only as a demonstration and to show that the transmit data is well received and to show it on port 4. The length of the data sent can obviously be increased. But one must take into account the hopping time to define the length of the data sent.

Following is the main function:

```
int main (void)
{
    _U8 returnCode = -1;
    _U8 txChannelIn, channel, rxChannelIn;

    //micro initialisation
    InitMicro();

    //transceiver initialisation
    InitRFChip();

    if (EnableTransceiver)//Transmitter
    {
```

```

//First channel for the synchronization
txChannelln = 0;
channel = txChannelln;

//Write datas in a buffer
RFbuffer[0]= 0x01;
RFbuffer[1]= 0x02;
RFbuffer[2]= 0x04;
RFbuffer[3]= 0x08;

while(1)
{
    //Pointer initialization to transmit the datas
    IniTxFreqHopping(RFbuffer,strlen(RFbuffer));

    //Synchronization phase
    channel = TxAcquisition(channel);

    //Hopping and data transmission
    returnCode = 0;
    channel = TxHopping(channel, &returnCode);

    //while datas are not totally transmitted,
    do
    {
        //Case where too much burst are lost
        if (returnCode & RX_LOSS)
        {
            channel = TxAcquisition(channel);//Go into synchronization phase
            returnCode = 0;
            //Hopping and data transmission
            channel = TxHopping(channel, &returnCode);
        }
    } while(!(returnCode & FRAME_TX_DONE));
}

}

else //Receiver
{
    //First channel for the synchronization
    rxChannelln = 0;

    //LO ajustement between transmitter and receiver
    FrequencyCorrection();

    //Synchronization phase
    RxAcquisition(rxChannelln);

    //Hopping and data reception
    channel = RxHopping(rxChannelln);

    while(1)
    {
        RxAcquisition(channel);//Synchronization phase
        channel = RxHopping(channel); //Hopping and data reception
    }
}
}

```

All the functions called by the main function are located in 3 files: INITIALISATION.C, XE1205DRIVERMSP430.C and FREQHOPPING.C.

6.1 INITIALISATION.C

This file contains the functions and sub functions used to initialize the microcontroller.

InitMicro : Initializes the MicroController peripherals

InitPort1 : Initializes the Port 1

InitPort2 : Initializes the Port 2

InitPort3 : Initializes the Port 3

InitPort4 : Initializes the Port 4

InitPort5 : Initializes the Port 5

InitPort6 : Initializes the Port 6

InitClockModule : Initializes the Clock Module. MCLK is first connected to DCOCLK and when LFXT1 is settled MCLK = LFXT1, SMCLK=DCOCLK (Res=0, DCO=0 -> freq=74.1 KHz).

InitTimerA : Initializes the Timer A

InitTimerB : Initializes the Timer B

6.2 XE1205DRIVERMSP430.C

This contains all the functions used to drive and initialize the XE1205.

The *InitRFChip()* function initializes the RF Chip according to the variable *RegistersCfg[]*. The XE1205 drivers developed under the MSP430 is very similar to the XE1205 drivers developed with the XE8000 (see API TN8000.18 "XE8000 driving XE1200 transceivers"). The sub functions prototype and name variables are conserved. So for more explanation about XE1205 driver, please refer to this API.

The XE1205 is initialized with a bit rate of 76.8 kbps and a frequency deviation of 80 KHz. The 20 dB bandwidth obtained is then 160 KHz, so lower than 250 KHz.

Configuration functions

InitRFChip: This routine initializes the RF chip registers using pre initialized variables

SetRFMode: Sets the XE1205 operating mode (Sleep, Receiver, Transmitter)

WriteRegister: Writes the register value at the given address on the XE1205

ReadRegister: Reads the register value at the given address on the XE1205

Communication functions

SendRfFrame: Sends an RF frame

ReceiveRfFrame: Receives an RF frame

SendByte: Sends data to the transceiver trough the SPI interface

ReceiveByte: Receives data from the transceiver trough the SPI interface

Utility functions

Wait: Creates a delay using the timer A and ACLK=1MHz clock

StartTimerCLK125KHz: Initializes and start the timer B to create an interruption when the delay is reached using the ACLK/8=125KHz clock

EnableTimeOut : Enables/Disables the RF frame timeout. When enabled, the timer A is initializes to create an interruption when the delay is reached using SMCLK/8 = DCOCLK/64 = 1168 Hz clock

InvertByte: Inverts a byte. MSB -> LSB, LSB -> MSB

SpilnOut: Sends and receives a byte from the SPI bus

Interruption functions

interrupt [PORT2_VECTOR] void Port2(void): interruption from IRQ0_RX_IRQ_WRITE_BYTE, used by *ReceiveRfFrame()* to receive a frame.

interrupt [TIMERA0_VECTOR] void Timer_A0(void): interruption from the timer A

6.3 FREQHOPPING.C

All the functions used for the frequency hopping protocol are located in this file.

Transmitter functions:

IniTxFreqHopping : Variables and pointers initialization for the frame transmission.

TxAcquisition : Tx acquisition phase. The transmitter hops to channels and sends the data SYNC. When an ACK is received, it means that Rx and Tx are synchronized. They then go into communication phase.

TxHopping : Tx hopping and communication routine. The transmitter hops and sends the data until the complete frame is not transmitted or until the synchronization is lost with the receiver.

TransmitBurst : Burst transmission

Wait_ACK : Set the transmitter in reception mode until it receives the data ACK or it receives an interruption from the timer meaning the end of the hop. When the data ACK is received, the transmitter is set in sleep mode until the end of the timer interruption.

Receiver functions:

FrequencyCorrection : Frequency error between transceiver and receiver. Frequency table correction.

RxAcquisition : Rx Acquisition phase. The receiver listens on a channel. When the data SYNC is received, it then sends the data ACK. Tx and Rx are then synchronized. They then go into communication phase.

RxHopping : Rx hopping and communication routine. The receiver hops and waits on a channel for data until a timeout. When data are received, it then sends an ACK and hops to the next channel. If no data are received and the timeout occurs, it then hops to the next channel +1 or return into synchronization phase if the number of lost burst is greater than MAXRXLOSSBURST

ReceiveBurst : The receiver is set in receive mode. It waits for data until a timeout occurs.

Common functions:

ChannelHop : Transceiver channel programming

© Semtech 2006

All rights reserved. Reproduction in whole or in part is prohibited without the prior written consent of the copyright owner. The information presented in this document does not form part of any quotation or contract, is believed to be accurate and reliable and may be changed without notice. No liability will be accepted by the publisher for any consequence of its use. Publication thereof does not convey nor imply any license under patent or other industrial or intellectual property rights. Semtech. assumes no responsibility or liability whatsoever for any failure or unexpected operation resulting from misuse, neglect improper installation, repair or improper handling or unusual physical or electrical stress including, but not limited to, exposure to parameters beyond the specified maximum ratings or operation outside the specified range.

SEMTECH PRODUCTS ARE NOT DESIGNED, INTENDED, AUTHORIZED OR WARRANTED TO BE SUITABLE FOR USE IN LIFE-SUPPORT APPLICATIONS, DEVICES OR SYSTEMS OR OTHER CRITICAL APPLICATIONS. INCLUSION OF SEMTECH PRODUCTS IN SUCH APPLICATIONS IS UNDERSTOOD TO BE UNDERTAKEN SOLELY AT THE CUSTOMER'S OWN RISK. Should a customer purchase or use Semtech products for any such unauthorized application, the customer shall indemnify and hold Semtech and its officers, employees, subsidiaries, affiliates, and distributors harmless against all claims, costs damages and attorney fees which could arise.

Contact Information

Taiwan	Tel: 886-2-2748-3380 Fax: 886-2-2748-3390	Switzerland	Tel: 41-32-729-4000 Fax: 41-32-729-4001
Korea	Tel: 82-2-527-4377 Fax: 82-2-527-4376	United Kingdom	Tel: 44-1794-527-600 Fax: 44-1794-527-601
Shanghai	Tel: 86-21-6391-0830 Fax: 86-21-6391-0831	France	Tel: 33-(0)169-28-22-00 Fax: 33-(0)169-28-12-98
Japan	Tel: 81-3-6408-0950 Fax: 81-3-6408-0951	Germany	Tel: 49-(0)8161-140-123 Fax: 49-(0)8161-140-124

Semtech International AG is a wholly-owned subsidiary of Semtech Corporation, which has its headquarters in the U.S.A